



# MODERN MANUFACTURING INDIA

WWW.MMINDIA.CO.IN

The Official Magazine of



Indian Machine Tool  
Manufacturers' Association

In Association with



## *Pioneering with* **INDIGENOUS INNOVATION**



OPED - WOMEN IN MANUFACTURING LEADERSHIP  
Reshaping the Manufacturing Landscape

24



INDIAN MACHINE TOOL EXPORTS  
Made in India for the World

38



RV GUMASTE  
Managing Director  
Kirkoskar Ferrous Industries Ltd (KFI)

34

# POWER UP AUTO COMPONENT MANUFACTURING

## VL1600 Vertical Machining Center

Revolutionize your auto die mould production with the VL 1600 Machining Center. Achieve exceptional heavy material removal, precise dies, and impeccable surface finish with STM's VL 1600. Take your manufacturing to new heights with the VL 1600 advantage.



Manufacturing Unit  
of S&T Group

3000+  
INSTALLATIONS

Across India



### Features & Benefits

**4 Guideways in Y-axis**  
Enhanced stability and precision.

**Bigger Diameter Spindle**  
Improved cutting performance and rigidity.

**Tough Column**  
Robust construction for long-lasting performance.

**Wide Base**  
Increased stability and vibration absorption.

**S&T MACHINERY (P) LTD.**

+91-422-2590810 | +91 82200 44287 | info@stmnc.com | www.stmnc.com

Discover the meaning of value



**S&T  
GROUP**  
SINCE 1996



AUTOMOBILE



ENERGY

AEROSPACE



DEFENCE

INFRASTRUCTURE

HEALTHCARE

TEXTILE

OIL & GAS

PUMPS & VALVES

**DX Large Series**  
CNC Large Turning Centre



**AX Series**  
CNC Turn Mill Centre



**EX Series**  
5-Axis CNC Moving Column  
Machining Centre



**K3X8 FIVE**  
5-Axis CNC High Speed Bridge Type  
Vertical Machining Centre



**MX 12**  
5-Axis CNC Universal Machining Centre



**MTX Series**  
CNC Multi Tasking Machining Centre

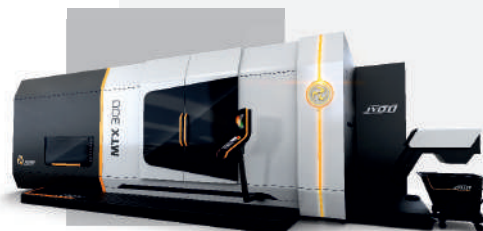

**JYOTI CNC AUTOMATION LTD.**

G – 506, G.I.D.C. Lodhika, Village : Metoda, Dist : Rajkot – 360021, Gujarat (INDIA).

T + 91 – 2827 – 235100/101, E info@jyoti.co.in, sales@jyoti.co.in jyoti.co.in

JyotiHuron

# CONTENTS

VOL 7, ISSUE 6 - MARCH-APRIL 2024



16



38



44



54



64

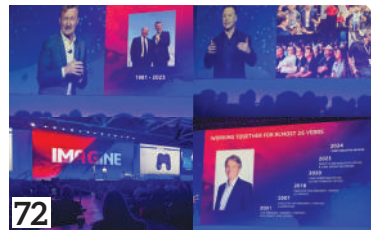

72

06	FOREWORD	44	FILTRATION SYSTEMS SETTING NEW STANDARDS
08	PUBLISHER'S NOTE	48	AUTOMATION IN AUTOMOTIVE EMBRACING AUTOMATION FOR UPPING PRODUCTIVITY
10	EDITORIAL	54	SMART MANUFACTURING DIGITAL TWIN: THE DOORWAY TO SMART MANUFACTURING
12	INDUSTRY OUTLOOK OPTIMISM IN THE AIR	56	CAPACITY ENHANCEMENT OF HIGHER TONNAGE MACHINES WITH THE CUSTOMER IN MIND
14	IMTMA'S DESK INDIA, A MANUFACTURING HOTSPOT FOR GLOBAL FIRMS	60	LASER WELDING AUTOMATION WELDING ON EV BATTERY AND AUTOMATION
16	TECH TALKS AI IN THE MACHINE TOOL INDUSTRY	62	ACADEMIA PROJECT RECYCLING FOR A BETTER TOMORROW
20	VIEWPOINT NAVIGATING SENSOR MARKET INSIGHTS	64	EVENT SNAPSHOT IMTEX FORMING 2024 & TOOLTECH 2024
24	OPED - WOMEN IN MANUFACTURING LEADERSHIP RESHAPING THE MANUFACTURING LANDSCAPE	70	EVENT SNAPSHOT MOTION MEETING 2024
28	COVER STORY PIONEERING WITH INDIGENOUS INNOVATION	72	EVENT SNAPSHOT 3DEXPERIENCE WORLD 2024
34	BIG INTERVIEW BEING LIMITLESS	74	SUBSCRIPTION FORM
38	INDIAN MACHINE TOOL EXPORTS MADE IN INDIA FOR THE WORLD	74	COMPANY INDEX & ADVERTISER INDEX

# IMPRINT

PUBLISHER

DIRECTOR GENERAL, IMTMA

EDITORIAL

Editor-in-Chief

Soumi Mitra

Chief Copy Editor

Poonam Pednekar

Senior Sub-Editor

Sovan Tudu

Senior Correspondent

Murali Sundaram

Design

Magic Wand Media

SALES & MARKETING

Indian Machine Tool Manufacturers' Association  
(IMTMA)

Murali Sundaram, Magic Wand Media Inc

[murali.sundaram@magicwandmedia.in](mailto:murali.sundaram@magicwandmedia.in)

Published and Printed by Indian Machine Tool Manufacturers' Association (IMTMA). Printed at Pentaplus Printer's Pvt Ltd Sy.No.1/2 Situated at Anjanadari Estate, Lingadeeranahalli, Adjacent to D Group Society Yeshwathpur Hobli, Bangalore North - 560091, Karnataka and Published from Indian Machine Tool Manufacturers' Association; Head Office: 10th Mile, Tumkur Road, Madavara Post, Bengaluru - 562123, Karnataka. Editor: Soumi Mitra

Publishing frequency: 6 times per year

Manuscripts: No liability is accepted for unsolicited manuscripts. They will be returned only if accompanied by sufficient return postage.

All rights reserved. Reprints, digital processing of all kinds and reproduction only by written permission of the publisher. Any views, comments expressed are the sole responsibility of the respective authors, IMTMA and Modern Manufacturing India and its partners do not undertake any responsibility, implied or otherwise.

**Disclaimer:** Every effort has been taken to avoid errors or omissions in this magazine. In spite of this, errors may creep in. Any mistake, error or discrepancy noted may be brought to our notice immediately. It is notified that neither the publisher, the editor or the seller will be responsible in respect of anything and the consequence of anything done or omitted to be done by any person in reliance upon the content herein. This disclaimer applies to all, whether subscriber to the magazine or not. © All rights are reserved. No part of this magazine may be reproduced or copied in any form or by any means without the prior written permission of the publisher. All disputes are subject to the exclusive jurisdiction of competent courts and forums in Bangalore only. While care is taken prior to acceptance of advertising copy, it is not possible to verify its contents. IMTMA cannot be held responsible for such contents, nor for any loss or damages incurred as a result of transactions with companies, associations or individuals advertising in its newspapers or publications. We therefore recommend that readers make necessary inquiries before sending any monies or entering into any agreements with advertisers or otherwise acting on an advertisement in any manner whatsoever.

THE EPITOME OF  
FINE FINISH & HIGH ACCURACY



JG Series – High Speed Vertical Machining Centers



JV Series – Large Vertical Machining Centers



J Series – Next gen Vertical Machining Centers



LL Series – Horizontal Turning & Turnmill Centers

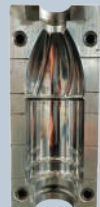
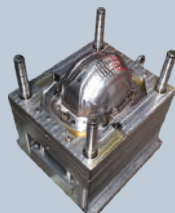
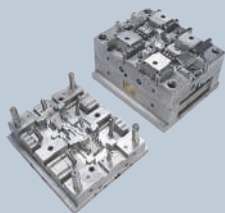

www.lmwnc.com



FOLLOW US ON:  
  
LMW CNC

INDIA'S FINEST  
RANGE OF CNC MACHINES

**LAKSHMI MACHINE WORKS LIMITED**

MACHINE TOOL DIVISION

+91 422 719 1300 | mtd\_marketing@lmw.co.in

\*Information provided is subject to change

# INDIA'S PURSUIT OF GROWTH AMIDST GLOBAL CHALLENGES



*Rajamane*

**RAJENDRA S RAJAMANE**  
PRESIDENT  
IMTMA

In recent years, India has been the cynosure of all eyes with its ever-improving economy. As per a report by S&P Global Market Intelligence, India's nominal GDP is slated to reach around US\$7.3 trillion by 2030. By then, it may overtake Japan and Germany, becoming the world's third-largest economy by the close of the decade.

The investment climate in India is positive with key sectors like Information Technology, Services, Agriculture, Manufacturing etc., slated to do well.

Whether India can continue to sustain this projected growth is a question that needs an afterthought with the picture getting clearer as days pass.

The Union Budget 2024-25, albeit interim, has received a thumbs-up from Manufacturing industry stakeholders. While presenting the Budget, Hon'ble Finance Minister made a conscious effort to ensure that the sops may trickle down to the end users, resulting in demand for goods and services eventually. Once this hits the top gear, the economy will undoubtedly move on the right track to not just meet the US\$5 trillion mark but achieve more in the years to come.

Manufacturing is expected to be one of the key contributors to the GDP in the growth story of India. The constant evolution of manufacturing technologies is essential for meeting the growing demand, and the Machine Tool industry has to traverse the extra mile with vigor to keep pace with the growth.

*As per a report by S&P Global Market Intelligence, India's nominal GDP is slated to reach around US\$7.3 trillion by 2030. By then, it may overtake Japan and Germany, becoming the world's third-largest economy by the close of the decade.*

To augment this endeavor further, Indian Machine Tool Manufacturers' Association (IMTMA) is organizing the third edition of Pune Machine Tool Expo 2024 and the first edition of FACTEQ 2024, an exhibition on factory equipment at Pune International Exhibition and Convention Centre in Moshi, Pune, from May 23 - 26, 2024.

I call upon the manufacturing fraternity to participate in the expo and avail the opportunity of one-on-one discussions, networking, and collaborations with numerous stakeholders.

Happy reading.

**Hurry Up !**  
**Limited Booths Remaining**



# IMTOF 2024

INTERNATIONAL MACHINE TOOL FAIR

**18 19 20 21 22 April 2024**

**Chennai Trade Centre, Chennai**

- ▶ **500 ++ Exhibits**
- ▶ **Technical Sessions**
- ▶ **Product Launches**
- ▶ **50,000 Business Visitors**
- ▶ **Live Demonstrations**
- ▶ **Open Only for Business Visitors**

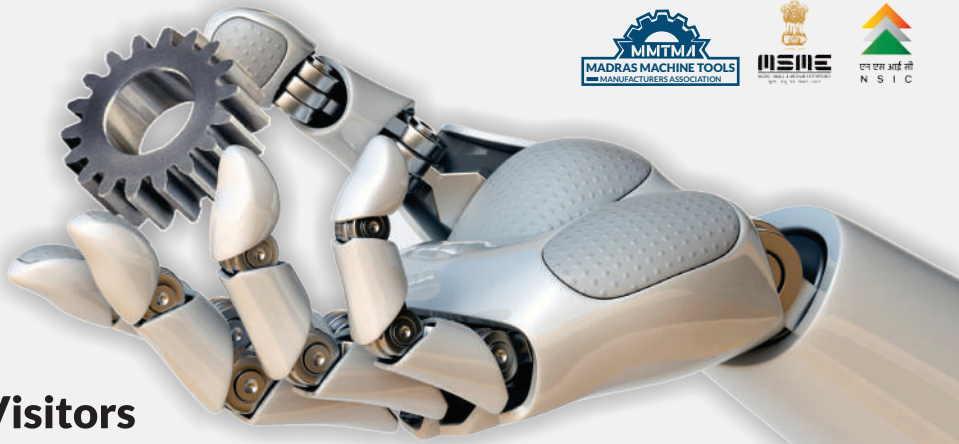

**Global Opportunities to**

**Gain Exposure, Networking Opportunities , Stay Competitive, Market Expansion, Brand Recognition, Industry Benchmarking, Public Relations, International Collaboration**

**Platinum Sponsors :**



**Silver Sponsors :**



**Compressor Partner :**



**+91 - 72009 76882 / 81**

**info@imtof.in**

**www.imtof.in**



**JIBAK DASGUPTA**  
DIRECTOR GENERAL & CEO  
INDIAN MACHINE TOOL MANUFACTURERS' ASSOCIATION  
BANGALORE INTERNATIONAL EXHIBITION CENTRE

Dear Readers,

When it comes to attaining manufacturing excellence there aren't any pre-defined success mantras. Innovations too do not happen by taking recourse to shortcuts. The herculean efforts that a multidisciplinary team of engineers and researchers put into developing a new technology while staying away from public glare culminate in a product finding the light of day.

Yet, when it comes to pinpointing what worked well in the success of a product, companies find it tough to give a definite answer. Although firms are candid in admitting this, the plain fact is that they strive to put in their best efforts in developing a technology and wait with fingers crossed on how it will be received in the market once they launch it.

We saw this happening in IMTEX and many other manufacturing technology exhibitions. Some find instant acceptance while some accept over a period of time. Deciding to procure a technology, after thorough consideration, is one of the crucial decisions made by firms, given that a wrong decision could seriously impact their future strategies.

With the dynamics of manufacturing technology changing constantly one marvellous innovation of today may become obsolete tomorrow. Many Goliaths were knocked off their perch in the past when they failed to innovate and move with the times. In a market that is turning more cutthroat as the day wears, the writing on the wall is loud and clear – shape up or ship out.

Modern Manufacturing India (MMI), with its in-depth research and analysis, enables readers to stay in sync with the major events and trends that are shaping manufacturing industries worldwide and make changes accordingly.

*Many Goliaths were knocked off their perch in the past when they failed to innovate and move with the times. In a market that is turning more cutthroat as the day wears, the writing on the wall is loud and clear – shape up or ship out.*

Curated by professionals, this edition of MMI offers informed commentary on some of the pertinent issues affecting manufacturing industries. The edition also has an authored article from the Indian Machine Tool Manufacturers' Association (IMTMA) which gives a peek into the current investment climate in India's manufacturing sector.

As is the prevailing norm, the success of any magazine, or the lack of it depends on the support extended by its readers to a large extent, and getting the right feedback is highly crucial. IMTMA seeks this from its readers as it treads on its journey to achieve excellence in manufacturing for the Indian machine tool industry.

# Combining Eco-friendliness with High Productivity and High Accuracy

Emblem for  
Green-Smart Machine



**Green-Smart Machine**  
Powered by *Intelligent Technology*

## Two key technologies equipped on 「Green-Smart Machine」

Intelligent Technology that enables a machine  
to autonomously maintain high accuracy.

Over 60,000 units produced from 2001 to September 2022



**Thermo-Friendly Concept**

Energy-saving system  
for a decarbonized society

Over 42,000 units produced from 2014 to August 2022  
\*Including the predecessor ECO suite

**ECO suite plus**



\*Green-Smart machine is available on 5-axis machining centers, multi-tasking machines, lathes, and machining centers

## OPEN POSSIBILITIES

Okuma India Pvt Ltd

Plot No.89, Udyog Vihar, Phase-1,  
Gurugram-122016, Haryana, India  
TEL: +91-12-4425-0229

[www.okumaindia.com](http://www.okumaindia.com)

For more information  
about  
Green-Smart Machine



**LOKUMA**



*Soumi Mitra*

SOUMI MITRA  
 Editor-in-Chief  
 Modern Manufacturing India  
 soumi.mitra@magicwandmedia.in

## INCHING TOWARDS TECHNOLOGICAL SOVEREIGNTY

**W**ith the aim to foster growth, encourage investments, and accelerate home-grown capabilities, the Indian Government, for some time now, has been taking initiatives to promote the Semiconductor industry.

The recent foundation stone laying for three new semiconductor fabrication units (fab) at Dholera and Sanand in Gujarat and Jagiroad in Assam, respectively, is a testament to India's resolve to become a global hub in semiconductor manufacturing.

The plants will be established through a combined investment of INR 1.25 lakh crore. The plants in Dholera and Jagiroad will be built by Tata Electronics Pvt Ltd (TEPL). The Dholera Fab unit will be developed in collaboration with Taiwan-based Powerchip Semiconductor Manufacturing Corporation (PSMC). India's first AI-enabled fab is expected to create over 20,000 jobs, with an investment of around INR 91,000 crore.

Along similar lines, Tata Semiconductor Assembly and Test (TSAT) is to build a semiconductor assembly and test facility in Jagiroad with an investment of around INR 27,000 crore. The commercial production from both plants will begin in 2026, catering to the requirements of a myriad industry sectors such as automotive, power, electronics, consumer, and medical. The new plant is said to generate more than 27,000 skilled jobs.

Additionally, Murugappa Group-owned CG Power has partnered with Japan-based Renesas Electronics and Thailand-based Stars Microelectronics to come up with a new semiconductor facility in Sanand, which is worth INR 7,600 crore.

*“Vision is not enough.  
 It must be combined with venture.  
 It is not enough to stare up the steps,  
 we must step up the stairs.”*

To reduce dependence on imports and promote domestic production, the Indian Government incentivizes and lends full support to draw semiconductor companies to set up fabs in India.

MMI strives to curate content about indigenous innovations and breakthrough technological practices that mirror the journey we have crossed and to convey the sense of triumph of having come this far.

The current MMI issue compiles stories that reflect our progress toward self-reliance. We will be thrilled to gain your valuable feedback on the same for us to continue bringing value-added content.

# EPLAN

efficient engineering.

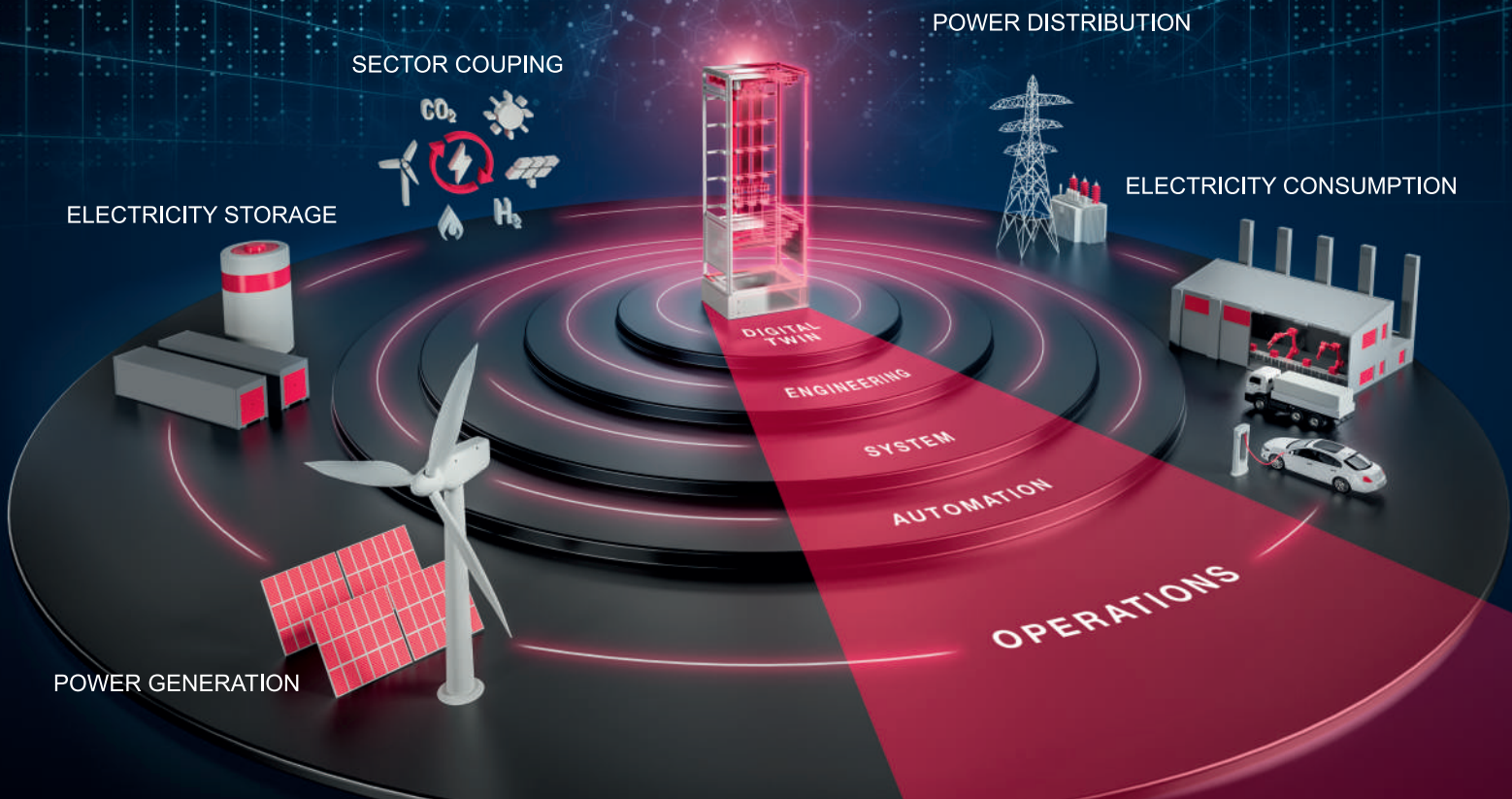

At **Eplan**, we are passionate about driving innovation and empowering industries through Efficient Engineering Solutions. Eplan Software provides innovative, practical solutions for workflow optimization for the machine manufacturing industry. Eplan Platform Solutions ensures a uniform basis for all engineering disciplines and provides high-quality documentation without any media break.

## Ready to take your Automation Engineering to the next level?

For further enquiries contact:



### **EPLAN Software & Services Private Limited**

NCC Urban Windsor, 3rd Floor, New Airport Road,  
Opposite Jakkur Aerodrome, Bengaluru - 560064

+91-80-61079100    www.eplan.in

**Ms. Pooja Narain**    +91 97311 57563    pooja.narain@eplan.in

PROCESS CONSULTING

ENGINEERING SOFTWARE

IMPLEMENTATION

GLOBAL SUPPORT

FRIEDHELM LOH GROUP



# OPTIMISM IN THE AIR

India's economic landscape showcased resilience and promise in the third quarter of the fiscal year 2023-24, driven by robust performances in key sectors.

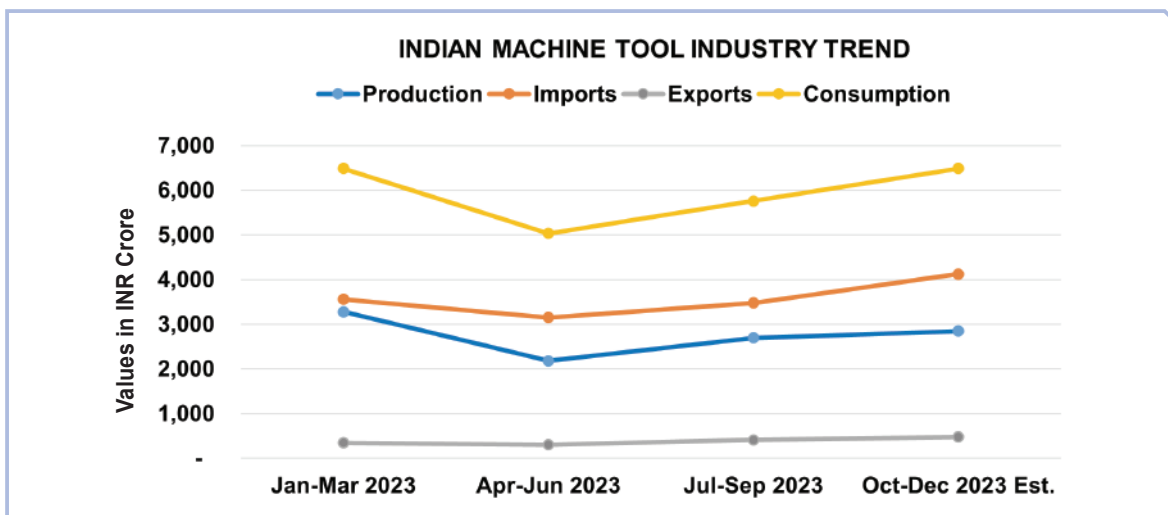

Table 1. Indian Machine Tool Industry Trend

**Indian Machine Tool industry production in CY2023 increased by about 9 percent year-on-year, reaching INR 12,520 Cr (US\$ 1.5 B). Machine tool exports during CY2023 from India reported an 8 percent growth, amounting to INR 1,543 Cr (US\$ 185 M) and consumption is estimated to have increased by 13 percent to reach INR 25,283 Cr (US\$ 3 B) in CY2023.**

**W**ith a remarkable double-digit growth rate of 11.6 percent in manufacturing and a solid 9.5 percent growth in construction, India's real GDP surged by 8.4 percent in the third quarter of FY2023-24. This growth trajectory was buoyed by a sharp increase in both manufacturing and services PMI levels, reaching 56.5 and 61.8 respectively in January 2024.

Accompanying this positive trend was an uptick in the Index of Industrial Production (IIP) growth, which rose to 3.8 percent in December 2023. Despite a slight moderation from the previous quarter, the IIP growth averaged at 5.8 percent, indicating sustained industrial momentum.

In its monetary policy review, the Reserve Bank of India (RBI) retained the repo rate at 6.5 percent in February 2024, underscoring its commitment to balancing growth with inflation management. Both the consumer price index (CPI) and wholesale price index (WPI) exhibited favorable trends, with CPI inflation easing to 5.1 percent and WPI inflation falling to 0.3 percent in January 2024.

Fiscal indicators also indicate a positive picture, with the Government of India's (GoI) Gross Tax Revenue (GTR) showing a growth of 14.4 percent during April-December FY24. Moreover, the FY25 Union Budget projected a reduction in fiscal and revenue deficits for FY24, indicating prudent fiscal management. Despite global economic headwinds, India's merchandise trade deficit reached a nine-month low in January 2024, showcasing improved trade dynamics amidst a challenging global scenario. With promising growth forecasts from international institutions like the IMF, India's economic growth trajectory continues to inspire confidence both domestically and globally.

## Indian machine tools scene

Indian Machine Tool industry production in CY2023 increased by about 9 percent year-on-year, reaching INR 12,520 Cr (US\$ 1.5 B). The industry's imports in CY2023 saw a rise of 16 percent year-on-year, amounting to INR 14,305 Cr (US\$ 1.7 B). Machine tool exports during CY2023 from India reported an 8 percent

growth, amounting to INR 1,543 Cr (US\$ 185 M) and consumption is estimated to have increased by 13 percent to reach INR 25,283 Cr (US\$ 3 B) in CY2023.

In CY2023, China (29%), Japan (21%), and Germany (10%) emerged as the top countries for imports, contributing to 60 percent of the total machine tool imports. Presses (13%), Vertical Machining Centers (VMC) (12%), and Turning Centers (11%) were the top machinery types imported, valued at INR 5,243 Cr (US\$ 634 M), constituting approximately 37 percent of total machine tool imports during the period.

While for exports, Russia (27%), USA (10%), and China (7%) emerged as the top three export destinations, accounting for 44 percent of total machine tool exports in CY2023, with a total export value of INR 679 Cr (US\$ 82 M). Turning Centers (17%), VMCs (13%), and Horizontal Machining Centers (11%) were the top three machinery types exported, valued at INR 631 Cr (US\$ 76 M), constituting approximately 41 percent of total machine tool exports during CY2023. 

# Drill Fix PRO™

## The Overachiever in Indexable Drilling



The new Drill Fix PRO indexable drilling platform is overdelivering in tool life, productivity and hole quality. It's the perfect tool for obtaining high-quality holes, primarily in general engineering applications, and comes with a wiper included in every outboard insert to deliver ideal surface quality.

**KENNAMETAL**  
62273756 7021402  
Ø25.0 X 3LD  
120041713 F2 NG00  
Made in Germany T2



LET'S TAKE YOUR MANUFACTURING  
TO THE NEXT LEVEL

[kennametal.com](http://kennametal.com)



# INDIA, A MANUFACTURING HOTSPOT FOR GLOBAL FIRMS

India has reinvented itself as a destination of choice in manufacturing for many global countries. This is evident with the increasing number of foreign firms shifting their base to Indian shores in the last few years.



Source: Magic Wand Media

**S**peaking of India's transformative journey and its emergence as a preferred destination for manufacturing, prime examples include Foxconn and Xiaomi in mobile manufacturing, Isuzu for commercial vehicles, and Tesla, which is in an advanced stage of negotiations with the Government of India for car manufacturing. Firms from other countries are also aiming to set up industries in India to cover the white space.

Interestingly, Walmart, an American multinational retail corporation, one of the world's

largest of its kind, is procuring more goods to the United States of America from India than from China, as per research conducted by Reuters.

Indian states are conducting various Global Investor Summits to provide a platform for in-depth discussions on the worldwide trends in manufacturing industries, showcasing indigenous opportunities and fostering deeper collaborations between private companies and Government enterprises.

Developments such as these make India a new battleground for foreign companies. The lure

to gain a slice of the colossus domestic customer base seems to be too good to ignore for these firms as they attempt to provide last-mile connectivity in manufactured goods and services.

## **Government support**

Manufacturing output is likely to continue expanding in 2024 and beyond on the back of high infra push by the Government and the various production-linked incentive (PLI) schemes for industrial sectors. For instance, PLI in electronics manufacturing would attract investments in phone



Source: Magic Wand Media

Manufacturing output is likely to continue expanding in 2024 and beyond on the back of high infra push by the Government and the various production-linked incentive (PLI) schemes for industrial sectors.

manufacturing and specific electronic components.

Industrial segments such as Defence, Pharmaceuticals and Healthcare, Renewable Energy, Automobiles (including Electric Vehicles), Information Technology, Artificial Intelligence, fast-moving Consumer Goods, and many others are beckoning foreign investments.

No wonder everyone is suddenly interested in India, especially in the aftermath of the success of the massive Digital India campaign launched and driven by the highest office in the land i.e. the Prime Minister's Office (PMO) under the leadership of the Honorable Prime Minister. India's digital economy has surged lately with smartphone penetration and high-level digital transactions, a jump in e-commerce activities, and the adoption of technology-based solutions.

Digital economy which accounted for less than 5 percent a decade ago is billed to make up around 20 percent or more of

India's GDP by 2026. This seems to be irresistible for the global manufacturing giants to stay away from.

Energy Storage Solutions, Green Hydrogen, Biotechnology, and Semiconductor Chip manufacturing are some emerging sectors that are poised for investment-led growth. India is determinedly moving ahead with its decarbonization initiatives with the Government aiming to have 500 gigawatt renewables capacity by around 2030. Simultaneously, companies are adopting ESG (environmental, social, and governance) best practices besides transforming their workforce to meet the new-age manufacturing demands.

**Toward sustainability**

All these throw up some interesting facts and figures with the most important one doing the rounds in India being the move to smart and sustainable manufacturing for crossing the US\$5 trillion economy target

and positioning itself as the third-largest economy by 2026-27. As one of the fastest-growing economies with institutional strength and improvement in governance, India is expected to overtake Japan and Germany by the end of the decade.

The Manufacturing industry, which currently contributes around 17 percent of the GDP, has been identified as one of the key components in this transformative journey. The argument is buttressed by a recent United Nations report titled 'World Economic Situations and Prospects 2024' which estimates a 6.2 percent growth in 2024 supported by domestic demand and growth in manufacturing.

As we move on, we will see India changing gears, diversifying its offerings, and focusing on manufacturing and exporting products that are demand-based globally. The resultant global trade and supply chain-related developments will act as enablers in this journey. 

## AI IN THE MACHINE TOOL INDUSTRY

The Machine Tool industry, a pivotal player in global manufacturing, stands on the brink of a revolutionary transformation driven by Artificial Intelligence (AI). This integration marks a significant departure from traditional manufacturing practices, heralding an era of smart manufacturing that surpasses the realms of mere automation.

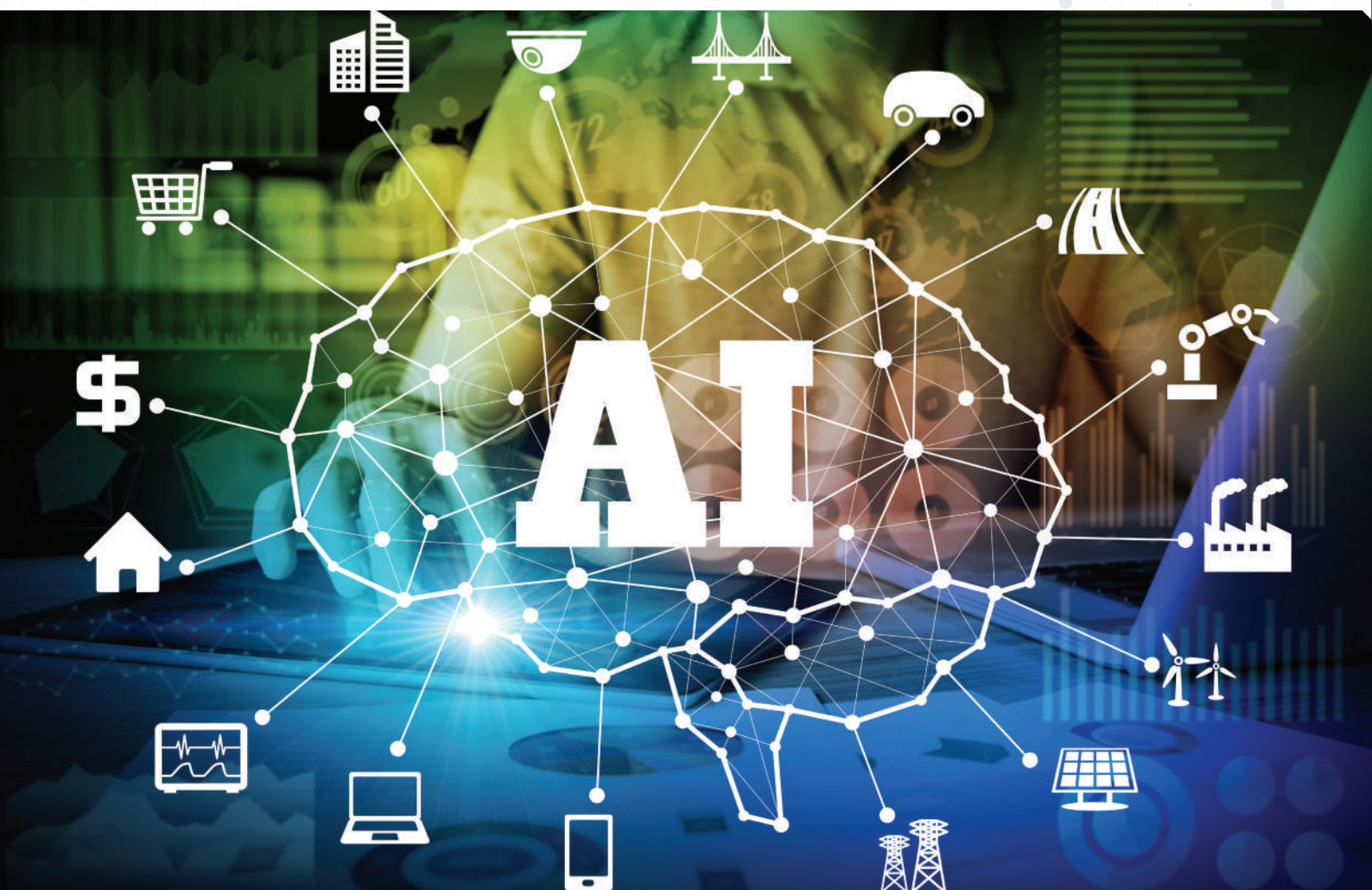

Source: Magic Wand Media

REJI VARGHESE  
MD  
RV Forms & Gears  
fngreji@gmail.com



**A**rtificial Intelligence (AI) in this context is not just an add-on technology but a fundamental pillar reshaping the industry's future. Its role extends well beyond automating repetitive tasks, encompassing a range of functionalities from predictive maintenance to real-time decision-making, all geared towards unprecedented precision and efficiency.

Marcus Taylor, COO, Planet Computers Ltd, says, "This transformative technology is rapidly becoming a mainstay in the Machine Tool sector, forging paths for innovations that were once considered futuristic. The influence of AI is evident in numerous facets of manufacturing, including enhanced operational efficiency, significant cost reductions, and a notable leap in product quality. As we delve deeper into the current state of AI in



“This transformative technology is rapidly becoming a mainstay in the Machine Tool sector, forging paths for innovations that were once considered futuristic. The influence of AI is evident in numerous facets of manufacturing, including enhanced operational efficiency, significant cost reductions, and a notable leap in product quality.”

**Marcus Taylor**  
**COO**  
**Planet Computers Ltd**

machine tooling, it becomes clear that this technology is not a fleeting trend but a cornerstone of modern and future manufacturing landscapes. Our new range of XR AI 5G computers and sensors are now being applied to CNC machines at the Institute of Technical Education for Human Centric AI, Singapore, to enhance training and improve productivity.”

### Key applications of AI in machine tooling

The integration of AI into machine tooling has brought about a renaissance in machining processes, redefining efficiency and precision. AI is making a significant impact on various areas:

**01 Predictive Maintenance:** At the forefront of AI applications in machine tooling is predictive maintenance. AI algorithms analyze data from sensors on CNC machines to predict when parts might fail or require maintenance. Taylor says, “This proactive approach significantly reduces downtime and maintenance costs, as issues can be addressed before they result in machine failure. For example, AI systems can monitor vibration, temperature, and sound patterns to predict spindle failures, one of the most costly and common issues in CNC machining.”

**02 Process Optimization:** AI also plays a crucial role in optimizing machining processes. By analyzing parameters such as cutting speed, feed rate, and tool path, AI algorithms can determine the most efficient machining strategies. This leads to improvements in efficiency, reduced material waste, and superior product quality. Moreover, AI-driven process optimization helps in adapting to different materials and machining conditions, enhancing the machine’s versatility and productivity.

Anil Bharadwaj, Managing Director, Yamazaki Mazak Pvt Ltd, says, “Mazak’s Smooth AI Spindle utilizes AI technology to optimize cutting conditions by monitoring spindle vibration and adaptively altering cutting Feeds & Speeds to remove the vibration. With optimum processes achieved, the cutting technology characteristics for the tool are stored in the MAZATROL or EIA NC program. Mazak’s AI Thermal Shield also automatically compensates the machine for temperature changes. Machine learning combined with Spatiotemporal modeling is used to increase the stability of processes with temperature change, further enhancing the machine’s accuracy.”

**03 Quality Control:** Taylor says, “Machine learning models are increasingly used for real-time quality control during the machining process. These models can detect anomalies or deviations from the expected outcome, significantly reducing the rate of defective products. By continually learning from new data, these systems become more adept at identifying and rectifying quality issues, ensuring consistently high standards.”

**04 Tool Life Management:** Another critical application of AI in machine tooling is in tool life management. Bharadwaj says, “AI systems can predict tool wear and determine the optimal time for tool replacement, thus ensuring consistent quality without unnecessary interruptions. This not only prolongs the life of the tools but also maintains the precision of machining operations.”

**05 Energy Efficiency:** AI applications extend to optimizing the energy consumption of CNC machines. Taylor says, “Through intelligent analysis and adjustments, AI-driven systems can

AI also plays a crucial role in optimizing machining processes. By analyzing parameters such as cutting speed, feed rate, and tool path, AI algorithms can determine the most efficient machining strategies. This leads to improvements in efficiency, reduced material waste, and superior product quality.

AI enables machines to adapt to varying material properties or unexpected conditions during the machining process. This adaptability improves the flexibility and efficiency of CNC machines.

“CNC machines equipped with AI capabilities are increasingly integrated into the broader framework of smart manufacturing. They can communicate with other machines and systems, enhancing overall productivity and decision-making. This integration is a key aspect of Industry 4.0, representing a shift towards interconnected and intelligent manufacturing ecosystems.”

**Ngawang Yonten**  
**Data Science**  
**Consultant**



reduce power usage, leading to more environmentally friendly operations and cost savings. This is particularly crucial in large-scale industrial settings where energy costs constitute a significant portion of operational expenses.”

**06 Adaptive Machining:** AI enables machines to adapt to varying material properties or unexpected conditions during the machining process. This adaptability improves the flexibility and efficiency of CNC machines, allowing for more complex and varied machining tasks to be performed with high precision.

**07 Machine Learning for CNC Programming:** Advanced AI algorithms are increasingly used to assist in generating or optimizing CNC programs. By analyzing design models and specific machine capabilities, AI can recommend the most efficient programming strategies, significantly reducing programming time and enhancing machine utilization.

**08 Integration with IoT and Industry 4.0:** Ngawang Yonten, Data Science, Consultant, who was part of the team that developed the award-winning Industry 4.0 solution Smartfix says, “CNC machines equipped with AI capabilities are increasingly integrated into the broader framework of smart manufacturing. They can communicate with other machines and systems, enhancing overall productivity and decision-making. This integration is a key aspect of Industry 4.0, representing a shift towards interconnected and intelligent manufacturing ecosystems.”

**09 Human-Machine Interaction:** AI has significantly enhanced the interaction between CNC machines and operators. Intelligent interfaces

and decision-support systems make it easier for operators to manage complex tasks and make informed decisions, thereby increasing productivity and reducing the likelihood of errors. Taylor says, “These applications of AI in machine tools represent a significant leap forward in manufacturing technology. They not only improve efficiency and quality but also open up new possibilities in terms of what can be achieved with CNC machining. As AI technology continues to evolve, we can expect these applications to become more sophisticated, further revolutionizing the machine tool industry.”

#### **The future of AI in machine tools**

The trajectory of AI in the Machine Tool industry points towards a future where manufacturing is not only smarter but also more interconnected and intuitive. The potential advancements in AI promise to further revolutionize this sector, driving innovation in machine tool design, operation, and maintenance.



“AI systems can predict tool wear and determine the optimal time for tool replacement, thus ensuring consistent quality without unnecessary interruptions. This not only prolongs the life of the tools but also maintains the precision of machining operations.”

**Anil Bharadwaj**  
Managing Director  
Yamazaki Mazak Pvt Ltd



**Real-Time Adaptive Control:** “One of the most exciting prospects is the development of real-time adaptive control systems. These systems will enable CNC machines to make instant adjustments during the machining process, accommodating for variations in material properties, tool wear, and external conditions. This will not only improve machining accuracy but also enhance the flexibility of manufacturing processes, allowing for more complex and customized production runs,” says Taylor.

**Intelligent Optimization of Production Processes:** Yonten says, “AI is set to play a pivotal role in the holistic optimization of production processes. By analyzing data across the entire manufacturing chain, AI systems can identify bottlenecks, predict issues before they arise, and suggest improvements. This level of intelligence will lead to significant gains in efficiency, productivity, and cost-effectiveness.”

**Enhanced Human-Machine Collaboration:**

The future also holds promise for enhanced human-machine collaboration. Taylor says, “With the advancement of AI, we can expect more intuitive interfaces and decision-support tools that make it easier for operators to interact with CNC machines. This will not only improve the user experience but also enable operators to leverage AI capabilities more effectively, leading to better outcomes.”

**Learning and Evolving Systems:** As AI technologies continue to mature, we will see systems that are capable of learning and evolving over time. These self-improving systems will be able to adapt to new challenges and continuously optimize their performance, ensuring that manufacturing processes remain at the cutting edge.

**Integration with Emerging Technologies:** Taylor says, “The integration of AI with other emerging technologies such as the Internet of Things (IoT), advanced robotics, and augmented reality will create even more opportunities for innovation. This convergence will lead to the creation of highly sophisticated manufacturing ecosystems that are responsive, efficient, and adaptable.”

The future of AI in the Machine Tool industry is not just an extension of current trends but a leap into a new era of manufacturing intelligence. With AI at the helm, the Machine Tool industry is poised to redefine what is possible in terms of efficiency, precision, and innovation. 

As AI technologies continue to mature, we will see systems that are capable of learning and evolving over time. These self-improving systems will be able to adapt to new challenges and continuously optimize their performance.



*Tech Talks is a column by industry veteran and journalist Reji Varghese that talks about the latest advancements in Machine Tools, provides snippets from history, interesting facts, etc. about the Machine Tool industry.*

## NAVIGATING SENSOR MARKET INSIGHTS

While the manufacturing market is surging with industrial IoT and smart tech, predictive maintenance is holding profit potential for industry players.

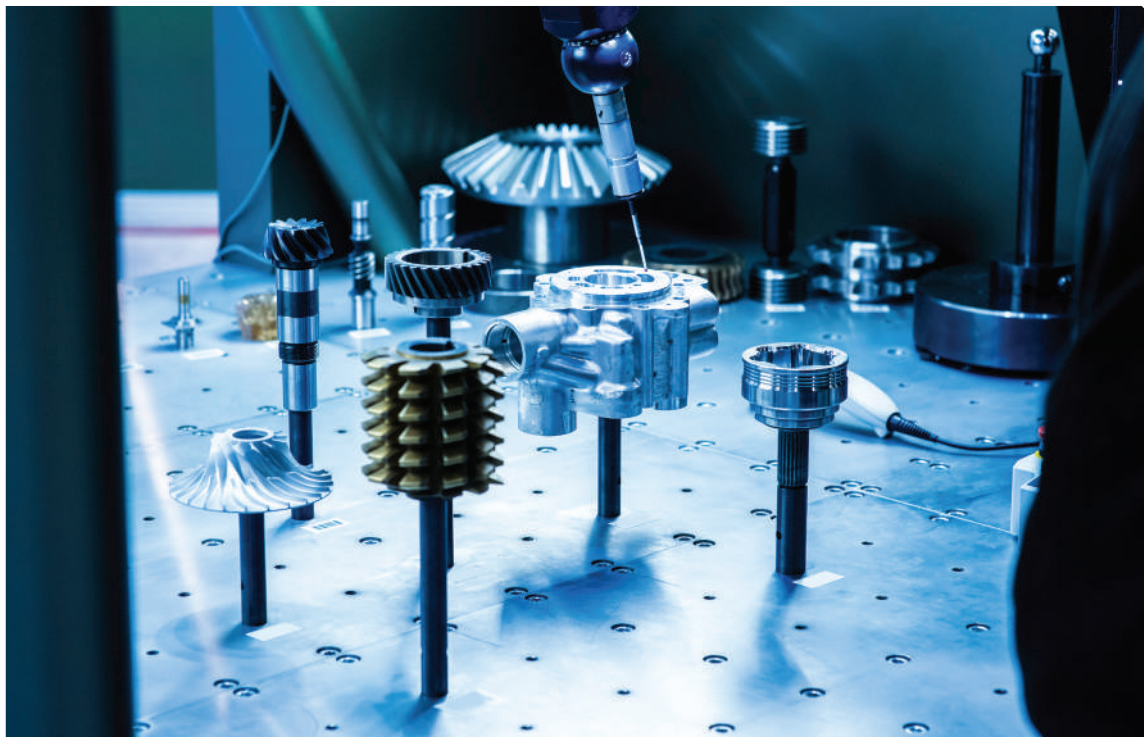

Source: Magic Wand Media

**I**n the rapidly evolving industrial landscape, the surge of intelligent sensors has become transformative, redefining machinery operations. The integration of wireless sensors, monitoring performance and failures independently brings heightened adaptability, safety, and reliability. However, challenges persist in developing performance-specific variants for varied applications, impacting small to medium-sized enterprises. The integration of predictive maintenance presents promising prospects, aligning with the industry's IoT-driven future. The diverse segmentation of sensor types, from temperature to force sensors, plays a pivotal role in industrial processes, ensuring operational safety and enhanced production. This sensor-rich future holds immense

potential, shaping the way industries navigate safety, efficiency, and innovation.

### **Propelling momentum: Escalating demand for intelligent sensors across industries**

The worldwide surge of Industry 4.0 has triggered an unparalleled appetite for intelligent sensors within industries, propelling WIKA's initiatives in the Indian market. As machinery metamorphoses into increasingly sophisticated entities, the indispensability of wireless sensors grows. These advanced instruments independently oversee performance metrics, failures, and usage patterns, introducing heightened adaptability, safety, and reliability across industrial terrains. The accelerating adoption of the Industrial Internet

of Things (IIoT) adds fuel to this demand, with wireless sensors – marked by their compact design, low power consumption, and precision – playing a pivotal role in the evolutionary journey toward smart factories.

### **Key drivers of growth**

- **Improved Accuracy, Reduced Costs, and Technological Advancements:** The market's robust growth is propelled by the triad of improved accuracy, reduced operational costs, and ongoing technological advancements, fueling the adoption of intelligent sensor solutions.
- **Smart Homes and Smart Cities Development Spurs Sensor Demand:** The evolution of smart homes and smart cities emerges as a significant catalyst, amplifying the demand

PRASHANT SINHA  
Head of Marketing  
WIKA India



# The all-new VT850

VERTICAL TURNING LATHE

MEET THE PLUG-&-PLAY POWERHOUSE  
from the machineers of tomorrow

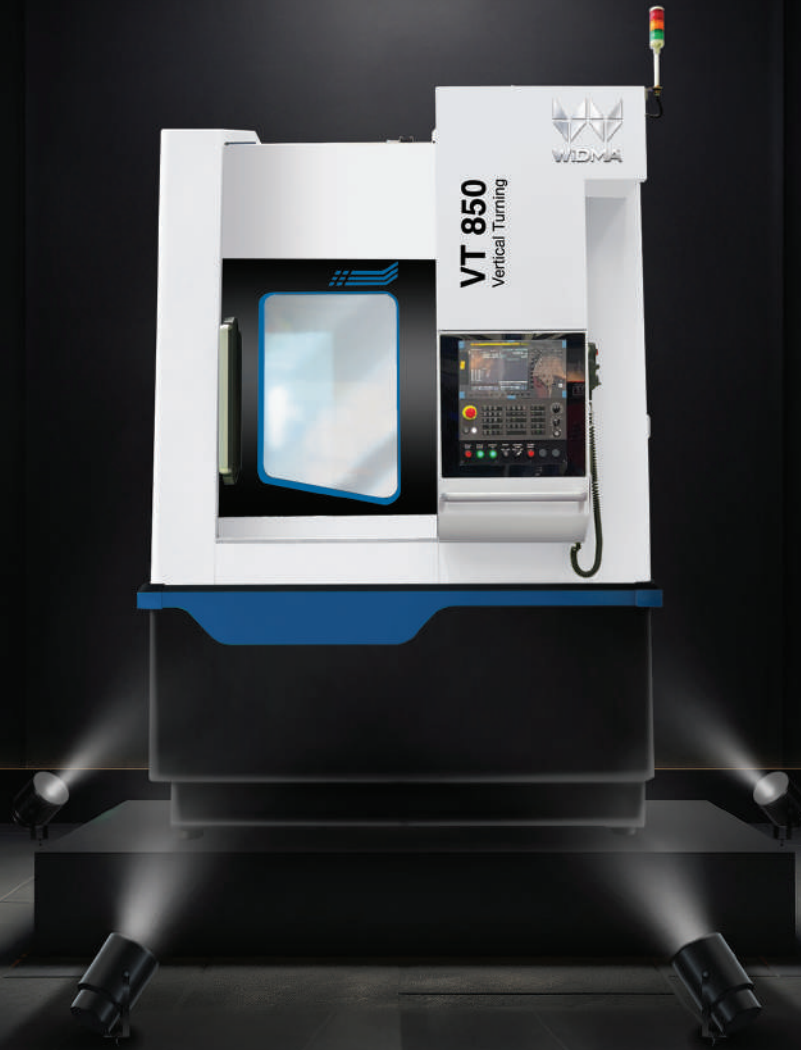

A 2-axis Vertical Turning Lathe, the VT850 is designed for machining large components that require heavy metal removal. Engineered for unparalleled productivity, it empowers our customers to perform a wide range of operations with greater cutting speed, depth, and accuracy. The VT850 is shaping a new era of machining, where accuracy, flexibility and productivity combine to make every cut count.



Easy  
Plug-and-Play



Advanced  
Accuracy



Best-in-Class  
Productivity



Unmatched  
Flexibility

**WIDMA Machining Solutions Group**

Kennametal India Limited

8/9th Mile, Tumkur Road, Bengaluru – 560 073, India

E-mail : [k-in.widma@kennametal.com](mailto:k-in.widma@kennametal.com) | Web site : [www.widma.com](http://www.widma.com)

The industrial sensor market exhibits a diverse segmentation, encompassing a wide array of types catering to specific functionalities. These include temperature sensors, pressure sensors, gas sensors, level sensors, force sensors, and humidity & moisture sensors.

for a diverse range of sensors catering to modern urban living requirements.

- **Industrial Automation and Industry 4.0 Proliferation as Growth Drivers:** The surge in industrial automation and the widespread proliferation of Industry 4.0 principles are identified as driving forces steering the upward trajectory of the sensor market.
- **Growing Demand for Quality Control, Predictive Maintenance, and Supply Chain Management:** The market's expansion is further fueled by an escalating demand for enhanced quality control measures, predictive maintenance solutions, and optimized supply chain management practices, reflecting the evolving needs of modern industries.

#### **Navigating challenges: Crafting specialized sensors for diverse performance needs**

Despite the growing demand for sensors, the complexities associated with developing performance-specific sensors tailored to various end-user applications present formidable challenges. The dynamic spectrum of requirements, spanning temperature, pressure, and flow characteristics, creates a substantial hurdle. This nuanced demand, spanning across industries, coupled with the significant costs linked to

research and development, particularly affects small and medium-sized enterprises, posing challenges to market growth.

#### **Key challenges**

- **Mounting Pressure to Reduce Manufacturing Costs:** The industry grapples with increasing pressure to minimize manufacturing costs, necessitating an innovative approach to sensor development that balances performance with economic considerations.
- **Amplifying Technological Advancements Increase Complexity:** The rapid pace of technological advancements contributes to the increasing complexity and sophistication of sensor design, requiring continuous adaptation to stay ahead in the market.
- **Stringent Standards and Growing Customization Demands:** The rising need to adhere to stringent standards and accommodate growing customization requirements across end-use industries adds a layer of complexity to sensor development.
- **Necessity for Specialized Knowledge and Skills amid Technical Complexity:** As technical complexity continues to rise, there is a growing necessity for industry players to acquire specialized knowledge and skills to navigate the intricate landscape of sensor development successfully.

#### **Seizing opportunities: Leveraging lucrative potential through predictive maintenance**

The integration of predictive maintenance, a strategic approach ensuring seamless operations within manufacturing systems, unveils promising prospects for WIKA India. This proactive maintenance strategy relies on the collection, transfer, and analysis of sensor data, underscoring the pivotal role of sensors in this evolving paradigm. With the manufacturing industry increasingly embracing Industry 4.0 and IoT, the heightened adoption of sensor-based technologies is expected to propel the growth trajectory of the sensor device market.

#### **Key opportunities:**

- **Automotive Industry Expansion Enhances Sensor Reliability:** The ongoing expansion of the Automotive industry is notably contributing to an increased reliability of sensors. Recent data indicates a 15 percent improvement in sensor reliability, aligning with the industry's commitment to enhancing performance and efficiency.
- **Growing Adoption across Healthcare and Biomedical Sectors:** The escalating adoption of sensor technologies across the Healthcare and Biomedical sectors presents substantial growth opportunities. Over the past year, there has been a 20 percent increase in sensor utilization within these sectors, emphasizing the potential for further market expansion.
- **Environmental Monitoring Amplifies Sensor Demand:** The increasing application of sensors in environmental monitoring, driven by growing concerns for climate change, amplifies the overall demand for sensor technologies. Recent developments show a 30 percent rise in the deployment

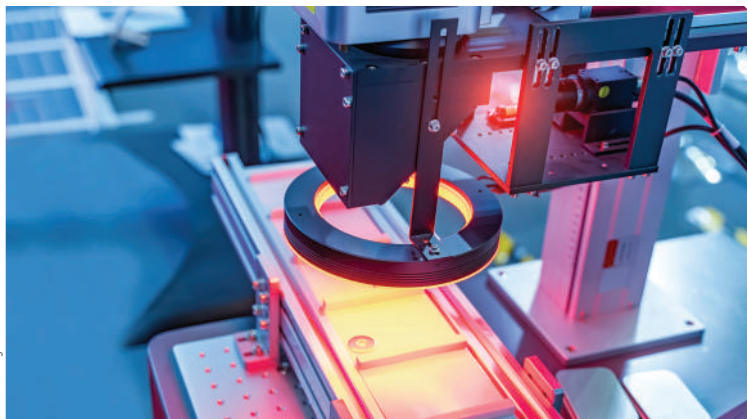

Source: Magix Wand Media

of sensors for environmental monitoring purposes, positioning this sector as a key driver for sensor market growth.

### Segmentation insights: Diverse sensor types and applications

The industrial sensor market exhibits a diverse segmentation, encompassing a wide array of types catering to specific functionalities. These include temperature sensors, pressure sensors, gas sensors, level sensors, force sensors, and humidity & moisture sensors. Notably, pressure sensors have asserted their dominance, finding extensive applications across diverse industrial processes such as Pneumatics, Hydraulics, Water Management, and more. Concurrently, the demand for level sensors is poised for substantial growth, fueled by increased vehicle production, ongoing innovation, and favorable regulatory frameworks.

### Key trends and influencers:

- **Growing Demand for Edge Computing:** An emerging key trend is the growing demand for edge computing, driven by an escalating need for sensor infusion across various industries. As of the latest market analysis,

there is a 15 percent year-over-year increase in the adoption of edge computing technologies, indicating a significant shift in sensor utilization trends.

- **Increasing Traction of Advanced Technologies:** The market is witnessing an increasing traction of advanced technologies, reflecting a dynamic landscape where sensors play a pivotal role. Recent data showcases a 20 percent surge in the adoption of cutting-edge sensor technologies, signaling a shift towards more sophisticated and efficient solutions.
- **Rising Integration of Artificial Intelligence (AI) and Machine Learning (ML):** The integration of AI and ML is becoming more prevalent to enhance sensor functionalities. Ongoing developments indicate a 25 percent rise in the integration of AI and ML in sensor applications, emphasizing the industry's commitment to leveraging advanced technologies for improved performance and efficiency.

### Sensor types: Non-contact and contact sensors

The global industrial sensors market further categorizes sensors into non-contact and contact variants. Non-contact sensors,

exemplified by resistance temperature detectors (RTDs), offer precise temperature measurements without heat transfer. Conversely, contact sensors, although requiring an electrical power source, are anticipated to witness growth due to their potential applications in precision scenarios, showcasing the evolving landscape of sensor technologies.

### End user insights: Diverse applications across industries

Within the industrial sensors market, WIKA India caters to diverse end-users, including Manufacturing, Oil & Gas, Mining, Pharmaceutical, and Energy & Power industries. In the Mining sector, sensors assume a pivotal role in ensuring operational safety, efficacy, and enhanced production. Similarly, the Pharmaceutical sector relies on sensors for achieving production and compliance targets, ensuring adherence to industry standards for labels and markings. In essence, WIKA Manufacturing in India is strategically positioned to navigate through these dynamic market forces, leveraging emerging opportunities, addressing persistent challenges, and contributing significantly to the ever-evolving landscape of industrial sensors. 

Ongoing developments indicate a 25% rise in the integration of Artificial Intelligence and Machine Learning in sensor applications, emphasizing the industry's commitment to leveraging advanced technologies for improved performance and efficiency.



**M** MODERN MANUFACTURING INDIA  
WWW.MMINDIA.CO.IN

The Official Magazine of  In Association with   
Indian Machine Tool Manufacturers' Association

**Get Curated Content on Advanced Manufacturing in your Inbox**

**SUBSCRIBE!**

  
@IMTMA IMTEX  
Scan & Pay with Cards & UPI  
HDFC BANK

# RESHAPING THE MANUFACTURING LANDSCAPE



In celebration of Women’s Day this month, it’s crucial to acknowledge the pathbreaking strides women have been making in the field that once was considered off-limits for them. They have come a long way from making a foray into the industry to assuming leadership roles and redefining the norms. Here are two cents from some significant women leaders who have not just risen to success but have worked toward making the manufacturing arena gender inclusive.

POONAM PEDNEKAR  
Chief Copy Editor  
Magic Wand Media Inc  
poonam.pednekar@  
magicwandmedia.in



**A**ccording to an analysis of government data by the Center for Economic Data and Analysis (CEDA) at Ashoka University, only 1.6 million women in India are working in manufacturing. Women make up around 20

percent of India’s factory workers, a share that has remained the same over the past two decades, according to CEDA. To check this, many companies have made it their agenda to increase gender diversity in their workforce. Some have intro-

duced assembly lines that are entirely run by women. To further bolster this positive change, it’s crucial we learn from the following torchbearers for gender equality in manufacturing and make the space more empowering for women.

## Ace Designers Ltd



**MADHAVI CHANDRASHEKAR**  
Executive Director  
Ace Designers Ltd

### “**Required skill sets in manufacturing**

I would classify the skills required in manufacturing into two broad categories, technical and personal skills. Under technical skills, I believe that proficiency in one or more technical aspects of manufacturing is essential. Added to this, a general understanding of allied technologies is also critical. As we progress into the 5<sup>th</sup> Industrial Revolution, adapting to digitalization through technologies like IoT, AI, and big data analytics will

also become necessary.

Some personal skills to consciously develop are problem-solving, critical thinking, continuous learning, effective communication, and time management.

### **Self-care comes first**

More than advice, I would like to share some thoughts based on my experience. First and foremost, in addition to developing domain expertise, young women should learn to be confident and assertive. They should not hesitate to speak their mind and share their ideas. Women should also work on building a network of like-minded peers and mentors who can help them navigate their careers in a male-dominated industry like manufacturing.

Managing work-life balance is essential for everyone and more so for young women. One must clearly define boundaries both in their personal and professional life and should learn to set realistic expectations of themselves. Women should also prioritize self-care and learn to delegate.”

## Automotive Component Manufacturers Association of India



**SHRADHA SURI MARWA**  
President  
Automotive Component Manufacturers Association of India (ACMA)  
Chairperson & Managing Director  
Subros Ltd

### “**Automation and Robotics have made the sector inclusive**

The Manufacturing sector, propelled by the rise of automation and robotics, has become increasingly inclusive. As technical skills take center stage like never before, the job roles in the Manufacturing sector are becoming more and more gender-agnostic. The ability to embrace innovation, navigate

complex supply chains, and lead teams with agility are critical attributes that drive growth and resilience in this evolving sector.

### **Technical know-how crucial for women**

To the young women entering the manufacturing space, it's crucial to focus on acquiring technical know-how and keeping abreast of advancements towards Industry 4.0. This transformative integration of digital technologies into manufacturing is revolutionizing the workplace and enabling more women to join the sector. The focus should be on embracing continuous learning, seeking mentorship, and developing skills in areas such as digitalization, automation, and sustainability. In today's age, women not only excel but also inspire positive change, shaping the future of manufacturing in profound and lasting ways.”

## Electropneumatics & Hydraulics India Pvt Ltd



**INGRID RASQUINHA**

**Jt Managing Director**

**Electropneumatics & Hydraulics India Pvt Ltd**



### **Honing the needed skills**

The requirements defined by a job profile (technical, behavioral, etc.) are the skills any person venturing into the manufacturing world needs to have, be it a man or woman. Women should first believe in themselves and have the confidence that they can hold their own in a largely male-centric manufacturing industry. Having strong engineering skills and qualifications is certainly an advantage. Additionally, impressive communication and interpersonal skills, and an attitude of self-learning and upgrading oneself as per the demands of the industry are always beneficial. Earlier women would not consider a career in manufacturing since it was considered a predominantly male-dominated sector. Also, the picture painted of manufacturing was about heavy-duty shop floor work, oily machines, and late/long working hours. But today there is much more to a manufacturing role for a woman. And it has been realized that it can be interesting and enjoyable too.

### **Naturally gifted**

While it is understood that one should have the requisite skills demanded by the job, women can make an additional marked difference with their unique skills. They often are more organized and detail-oriented, have better problem-solving skills, are good at multitasking, and are more creative. They also bring a valuable emotion quotient to the workplace.

There is nothing that should stop a woman from stepping into the manufacturing sector, be it in design, production, planning, sales, finance, sourcing, marketing communications, HR, and more. In fact, as a woman, we have a great advantage of being noticed and making a mark.

One should aim high and refrain from selling themselves short. One should not let bias influence their decision. The common conundrum for women is the guilt factor – family or work. Women can do justice to both. It is tough but every woman should give equal priority to themselves and their personal goals as they do to their societal and familial commitments, without feeling guilty.

With the world moving towards inclusivity and more women empowerment, workplaces are also becoming sensitive to the needs of women. The number of women in the Manufacturing industry has been steadily rising over the years, and they are being welcomed too. So, we need to primarily break the barriers we form in our own minds.

Most companies, and certainly Electropneumatics are consciously working towards engaging and mentoring more women to consider manufacturing as a career path, encouraging them to rise to the top, and providing opportunities for it.

My journey of 27 years in the Machine Tool manufacturing sector has been wonderful and gratifying. There have been a few impediments along the way (the biggest being motherhood), but I have been blessed with a father, brother and husband who supported me unconditionally and pushed me at every step.

There is no better time than now to step into the growing manufacturing sector, especially in India. The opportunities are encouraging and inviting.



The Official Magazine of  
Indian Machine Tool  
Manufacturers' Association  
In Association with  
Modern  
Machine  
Shop

If you are reading this

**Print is NOT DEAD!!!**

**MMI: CONNECT WITH YOUR AUDIENCE**

For Advertising: Murali Sundaram • E: murali.sundaram@mmindia.co.in • M: +91 9740048390



## Indian Machine Tool Manufacturers' Association



**MOHINI KELKAR**

Vice-President, Indian Machine Tool Manufacturers' Association (IMTMA)  
Managing Director, Grind Master Machines Pvt Ltd

### “**Stress on automation**

The Manufacturing sector in India has substantially evolved in the past 20 years. Due to the influx of manufacturing new products, the demands on the components made in the Manufacturing sector have increased substantially in terms of part accuracy, productivity, and quality standards. The parts that had a 3-triangle finish earlier are now demanding a 4-triangle finish.

The predictability of delivery time and the quality of parts have substantially improved. With the rise in exports from India, there is stress on the traceability of defects and defect-free manufacturing. This has made Industry 4.0 systems or IoT or similar kinds of tracking systems important for tracking parts throughout the entire manufacturing process. Automation has become a norm even with MSMEs. Therefore, the knowledge of automation systems in any manufacturing set-up has become important. Hence, it is important to be skilled at and acquire knowledge in manufacturing technology that includes machines, manufacturing processes, tools, types of automation systems, and IoT. Robust manufacturing can be achieved when the right machines and processes are in place.

### **Manufacturing, right for young women**

Currently, the Manufacturing sector is highly conducive for young women. The opportunities in the sector are increasing manifold. The demand for skilled manpower has also escalated, which the male community is not fulfilling. Secondly, with automation coming into the picture, the demand for manual work has diminished. Hence, the criterion for physical strength is no longer valid, making women on par with men.”

## Sandvik Coromant



**HELEN BLOMQVIST**  
President  
Sandvik Coromant

### “**Manufacturing has a place for experts**

There is no denying that digital skills are not only increasingly competitive but also crucial. Today, the most valuable of skills required are those that are transferable to a whole range of industries benefitting from digital transformation.

It's important to recognize the pace at which the manufacturing sector constantly evolves. For companies to succeed as they embrace digitalization, they are actively seeking those with digital skills that can contribute to the adoption of advanced technologies, improve operational efficiency, and drive innovation. Harnessing these skills requires a diverse approach, with problem-solving and critical thinking at the center. Manufacturing is not how it was first perceived – a physical, hazardous environment – and there truly is a place for every type of expert.

### **Courage is the key**

According to socio-economic surveys conducted by the National Sample Survey Office (NSSO), women make up less than 20 percent of the workforce in India. While this is generally viewed as a cause for concern, one could instead see this as an opportunity.

One only has to look at women in leadership roles to know that anything is possible. Be brave, be curious, and don't fear mistakes and rejection. We learn from experiences and grow when we are uncomfortable. Women are worthy of their place in male-dominated environments like manufacturing; we just have to be courageous enough to show it.”



# *Pioneering with* **INDIGENOUS INNOVATION**

SUBBU  
VENKATACHALAM  
Head of Marketing  
Carborundum  
Universal Ltd



Indigenous manufacturers in the defence and aerospace industries, aided by policy reforms, are in a highly competitive landscape, striving to create a diversified mix of world-class products for the sectors while making the entire ecosystem self-reliant.

Source: Magic Wand Media



Source: Magic Wand Media

India's geopolitical influence has grown steadily formidable over the last decade. A key harbinger of such change has been the 'Atmanirbhar Bharat' or Self-Reliant India scheme, chiefly in critical sectors such as Defence. Encouraging indigenous manufacturing and R&D and partnering with private players to usher in material innovation and expand technological capabilities, while enlarging export contribution have formed the foundation for steady transformation in this direction.

### Policy change: A step in the right direction

Accelerating sectoral reforms through policy-level focus has given a shot in the arm to the Government's efforts. These include:

- Releasing the Department of Military Affairs' (DMA) five 'Positive Indigenisation Lists' and the Department of Defence Production's (DDP) four Defence Public Sector Undertakings (DPSUs) as per the directive to prioritize

phased procurement from domestic sources under the Defence Acquisition Procedure 2020;

- Simplifying the industrial licensing process and 'Make' procedure, opening up FDI in defence (74% under the automatic route);
- Introducing the iDEX or Innovations for Defence Excellence scheme involving startups and Micro, Small, and Medium Enterprises (MSMEs);
- Launching the SRIJAN indigenization portal;
- Implementing the Public Procurement (Preference to Make in India) Order 2017;
- Making amendments to the Defence Offset Policy over the years;
- Targeting greater investment and enabling easy technology transfer;
- Forming two dedicated Defence Industrial Corridors in Uttar Pradesh and Tamil Nadu.

The draft Defence Production & Export Promotion Policy

(DPEPP) 2020 is another positive move. With the ambition of positioning India as a world leader in defence manufacturing (aerospace and naval shipbuilding included), the policy aims to provide a major impetus to indigenous cutting-edge design and production through public sector undertakings and private companies. Its overarching goal is to strengthen self-reliance and expand the share of exports.

To ensure India's emergence as a major defence manufacturing hub, the policy sets out clear objectives:

- Realize a turnover of INR 1.75 lakh crore, including exports of INR 35,000 crore, in Aerospace and Defence goods and services by 2025;
- Foster a robust and competitive domestic defence industry to address the requirements of India's armed forces with world-class products and next-generation technology;
- Encourage indigenous design and manufacturing to enable

Encouraging indigenous manufacturing and R&D and partnering with private players to usher in material innovation and expand technological capabilities, while enlarging export contribution have formed the foundation for steady transformation in this direction.



Source: Magic Wand Media

According to statistics from the Department of Defence Production, the size of the defence industry, as of 2019-20 is estimated to be about INR 80,000 crore, with private sector contribution notching up over 21%.

significant import substitution;

- Expand exports of key defence products and emerge as a strategic contributor to the global defence value chain network;
- Build an ecosystem to encourage and reward innovation and R&D while underscoring IP ownership.

**Entry of private players: a game-changer**

While manufacturing capacity significantly expanded through the Ordnance Factories and DPSUs, the landscape was completely altered with the entry of licensed private players in 2001. This led to fast-paced innovation through the discovery of advanced materials as well as the evolution of new-age technology. This has opened the doors to a diversified mix of globally competitive products and services, including personal body armor, arms and ammunition, armored vehicles, military aircraft, warships, submarines,

missiles, and electronic equipment, coupled with specialized use of newer, high-performance materials.

According to statistics from the Department of Defence Production, the size of the defence industry, as of 2019-20 is estimated to be about INR 80,000 crore, with private sector contribution notching up over 21 percent.

While ensuring India stands tall in manufacturing, an array of cutting-edge, globally certified master products and components, private players have also enabled building in India for the world. As per the Ministry of Defence, India's exports in defence touched a record INR 15,920 crore, with 100 firms exporting to 85 countries in 2022-23, a 10x rise since 2016-17.

**Indigenous make, globally certified**

All the above positive measures have served to flip the switch, opening the doors to pioneering innovation in the areas of manufacturing, materials, technol-

ogy, and capabilities. Over the last 75 years of India's history as a Republic, several well-known private partners, smaller entities, and MSMEs have been committed to enabling this journey.

**Insulated from global supply chain pressures:** With completely localized end-to-end integration, many domestic private players are sourcing and manufacturing 100 percent in India. While this ensures that the sector is insulated from global headwinds, it also creates opportunities for startups and MSMEs to play a more active role in the space.

**Competitive landscape promoting IP and diverse innovations:** As per the Global Innovation Index 2023 published by the World Intellectual Property Organisation (WIPO), India has moved up from 81<sup>st</sup> place in 2015 to 40<sup>th</sup> place. Reforms to transform India into an innovation-focused economy, supported by a dynamic startup ecosystem, a vast pool of tal-



ent – employed and potential, the presence of premier educational institutes, and consistent R&D by industry in emerging technologies have all created a robust environment for patenting and innovation. Several big-ticket players are also consolidating their positions and expanding their R&D capacities. This highly competitive space has ensured top-notch, wide-ranging innovations in the Defence arena, exploring new and diverse avenues in technology, materials, and capabilities, fueled by the rapid pace of innovation.

**Welcoming new materials:** Foraying into newer areas of materials science requires deep expertise with a research-oriented focus to discover or welcome advanced, high-performance materials into the Indian market and manufacture commercially at scale. As an example, graphene has been touted as a ‘wonder material’, especially for Aerospace and Defence applications, due to its flexi-

bility, extraordinary strength, lightweight, and high thermal/electrical conductivity.

**Winning at stealth:** Stealth technology is a vital cog in Defence, delivering a critical make-or-break through radar cross-section reduction (RCSR). Among the four key techniques of RCSR is camouflaging with the application of radar-absorbing materials such as graphene. Graphene’s unique electromagnetic properties can potentially absorb radar waves, making these aircraft less detectable by enemy radar systems. This could potentially be the best method to improve stealth capabilities for military aircraft and unmanned aerial vehicles (UAVs). It doesn’t involve any design alterations to the aircraft while affording a minimal increase in weight.

**Right on target:** Through continuous R&D, breakthrough improvements in employing structural ceramics for missile radomes, have helped design

lightweight projectiles keen at precision targeting.

**Conforming to global standards:** Highly reliable, ergonomic, lightweight, and easily customizable ballistic solutions for bullet-proof vests, ballistic shields, and ballistic helmets have been engineered to meet up to ‘Level IV’ threat levels, conforming to international standards set out by the National Institute of Justice (NIJ).

**Redefining excellence through quality:** It is well known that the Defence and Aviation sectors are highly regulated, and suppliers are required to meet the most stringent quality standards. In this scenario, distinction through global certifications such as EN9100 and STANAG 4569 can afford a clear edge – in securing government and global contracts, as a talent magnet and cementing partnerships for deeper cooperation with top-tier research-oriented entities. A sure-fire way to attest to quality excellence, they enable

Through continuous R&D, breakthrough improvements in employing structural ceramics for missile components, such as ceramic radomes, have helped design lightweight projectiles keen at precision targeting.



Source: Magic Wand Media

For military applications of unmanned aerial vehicles (UAVs), choosing the right material is key. They should be hard yet lightweight, abrasion- and wear-resistant, and have low density while being highly ductile.

domestic producers to indigenize and supply items earmarked on the government's import embargo lists while easily exporting to Original Equipment Manufacturers (OEMs) globally.

**Making a material difference:** For military applications of unmanned aerial vehicles (UAVs), choosing the right material is key. They should be hard yet lightweight, abrasion- and wear-resistant, and have low density while being highly ductile. Graphene-based composites, carbon fiber-reinforced plastic (CFRP) and thermoplastic composites, and advanced ceramics such as boron carbide or silicon carbide are lightweight with high tensile strength - well-suited to design CFRP tubes, panels, landing gears, and customized composite structural parts. Advanced ceramics products for battle tanks and unmanned ground vehicles enable the highest levels of ballistic and blast protection. Sustained innovation in materials, whether developed in-house or through collaboration, is continually advancing material technology in the Defence and Aerospace sectors.

### Closer industry-academia connect

With premier research institutes such as the Indian Institute of Science (IISc) and the Indian Institute of Technology (IITs) offering advanced courses in materials science, the environment is conducive to active, research-led innovations in new materials aided by emergent technologies and industry sponsorship. This creates a win-win equation for all parties involved.

### Contribution to developing the larger ecosystem

Home-grown manufacturers are not only committed to setting up and expanding capacity supported by in-house R&D centers but are also contributing to developing the entire ecosystem dedicated to critical sectors such as Aerospace and Defence. They are doing this through employment, training and upskilling, collaborations with top-tier research entities and educational institutions and hiring local talent while augmenting India's share of exports in this space. A recent case in point is the significant number of Memorandum of Understanding (MoUs)

signed between the Government of Tamil Nadu and 53 industries and organizations committing to invest INR 11,794 crore across the 5 nodal cities forming the Tamil Nadu Defence Industry Corridor (TNDIC). As of February 2023, investments worth INR 3,861 crore have already been realized. The state's radial model also aims to target and integrate MSMEs with the aim to become India's strategic defence capital.

These sentiments were also echoed at the recently held Tamil Nadu Global Investors' Meet. While not only contributing to developing and expanding the share of innovative materials, products, capabilities, and technologies from the state, the focus is also on positively impacting the corridors themselves, partnering with smaller vendors and integrators, hiring and training local talent, and collaborating with state institutions in the field of research. As India enters its 76<sup>th</sup> year as a Republic state, we can proudly claim that innovation by indigenous manufacturers is imparting true meaning to 'Atmanirbhar Bharat' by enabling self-reliance across every sphere of influence. 



# Hyderabad International Machine Tool & Engineering Expo



**16 17 18 19**  
**August 2024**  
**HITEX, Hyderabad**

Gold Partner



Associate Partner



Compressed Air Partner



E- Magazine Partner



Media Partners



For Space Bookings, Sponsorship, Advertising, Please Contact us

Vinoth Sasidharan  
 9121211159 / sv@hitex.co.in

Himanshu Dwivedi  
 9154365906 / hd@hitex.co.in

Bora Shanthi Kumari  
 9154214270 / bsk@hitex.co.in

# BEING LIMITLESS

RV Gumaste, Managing Director, Kirloskar Ferrous Industries Ltd (KFIL), in the following interview with Soumi Mitra, Editor-in-Chief, MMI, offers an interesting insight into the company's strengths, its position in the world market, future plans, and sustainability practices.



RV Gumaste, Managing Director, Kirloskar Ferrous Industries Ltd (KFIL)

Source: KFIL

**What is the significance of Kirloskar Ferrous Industries Ltd's (KFIL) parent company's 130-year manufacturing and engineering legacy in shaping its approach to innovation and customer-centricity?**

**RV Gumaste:** For over 135 years, we at the Kirloskar Group, affectionately referred to as Kirloskar, have focused on the progress of economic self-sufficiency and industrial growth in India. Our first products, the iron

plough and chaff cutters, were introduced by our founder Hon. Late Shri Laxmanrao Kirloskar to encourage modernization in the Agricultural and Farming sector in the early 1900s.

Developed at a small-scale machine tool workshop behind a bicycle shop, the iron plough proved to be the first among many engineering innovations that the Kirloskar as a group would pioneer in the future.

Inspired by our founder's vision

and values, Kirloskar Group has built its foundation on strong business ethics, growth-driven innovation, quality products, and a commitment to corporate responsibility, ensuring the co-existence of industry and the environment. We have also consistently believed in adopting the latest technologies and embracing global cooperation, whether through joint ventures or technical collaborations, and being one of the first

SOUMI MITRA  
Editor-in-Chief  
Modern Manufacturing  
India  
soumi.mitra@  
magicwandmedia.in



in India to do so.

Our in-depth understanding of the dynamics of industrialization and market requirements has greatly aided in expanding our global reach to over 70 countries. As one of India's largest engineering companies, we, the Kirloskar Group, believe we have a responsibility towards our customers and the country to keep addressing the needs of our times and strive to transform as many lives as possible. In the process, we transform ourselves as well.

**Can you please elaborate on KFIL's founding mission and where it has reached in its journey to transform the Pig Iron and Grey Iron Casting industry?**

**RV Gumaste:** KFIL is an acknowledged market leader in India for manufacturing and supplying complex and critical Grey Iron Castings and quality Pig Iron. KFIL, a part of the Kirloskar Group (K-Group) of companies, one of the leading engineering conglomerates in India, was founded by the late Laxmanrao Kirloskar in the year 1888. KFIL has been built on a solid foundation of innovation and customer-centricity. In 2021, Kirloskar refreshed its brand with a new vision of customer centricity that has translated into a brand platform 'Limitless'. At Kirloskar, 'Limitless' is the ethos that defines how we operate - striving relentlessly to bring delight beyond boundaries to our customers.

Incorporated in 1991, KFIL commenced its operations in 1994. It is the only company in Asia that has integration from 'Mines to Machined castings'. KFIL has manufacturing locations in Koppal and Hiriyur in Karnataka and Solapur in Maharashtra, and has three business verticals i.e. Pig Iron business, Casting business, and Seamless metal tubes.

"KFIL is consistently progressing with an aspirational mission of becoming a US\$ 2 billion company by 2030. In this journey, we acquired and operationalized VSL Steels Ltd at Hiriyur in February 2021. We acquired the management control of Indian Seamless Metal Tubes (ISMT) Ltd in March 2022 and recently we have acquired Oliver Engineering Private Ltd (OEPL) by becoming a majority shareholder and induction of Directors on the Board of OEPL."

**RV Gumaste  
Managing Director  
Kirloskar Ferrous Industries  
Ltd (KFIL)**

**Please apprise us of KFIL's role in supplying castings and Pig Iron to the global Automotive industry, especially in terms of engine production.**

The Indian Foundry industry puts the country on the map as one of the top 5 nations in the world making castings. KFIL has contributed more than a million tonnes of castings used for various applications, including a wide range of engines across construction machines, farm equipment, and utility vehicles engineered by some of the world's largest automobile manufacturers.

The engine is the heart of any vehicle. KFIL supplies Cylinder Blocks and Cylinder Heads to some of the biggest players in the global and Indian Automobile industry. KFIL Pig Iron is used in making cast iron, which is the perfect input material for durable engines and other transmission parts. Our leadership team envisaged India's upgradation from Euro 3 to Euro 6 vehicle emission standards and the constant change in the design of the vehicle and engine and, thereby,

the change in the designs of casting as a continuous effort of new product development. With the same insight, we entered the industry with cylinder blocks and heads, tractor housing, and other solutions and moved closer to the raw material, the iron ore.

**How does KFIL's high-quality Pig Iron support the manufacturing of long-lasting machine tools?**

KFIL's Pig Iron Division is the largest producer of Pig Iron in India with a production capacity of 5 lakh tonne per annum. The Pig Iron Division started operations in 1994.

Pig Iron is an intermediate product and the first product of iron-making reduced from iron ore. It has a very high carbon content, typically 3.5-4.5 percent along with Silica, Manganese, Sulphur, Phosphorus, Titanium, and other trace elements.

Pig Iron comprises three main types basic grade Pig Iron, used mainly in electric arc steelmaking; foundry grade Pig Iron, used mainly in the manufacture of grey iron castings in cupola furnaces; and SG grade Pig Iron, used in the manufacture of ductile iron castings. Pig Iron is used for steel making, foundries, alloy making in automotive castings, and other iron-based castings.

As a leading Pig Iron manufacturer in India, we have developed a reputation for consistency in quality, delivery, and service. We focus on creating the ultimate value and convenience for the customer in everything that we do. This is the reason why each Pig Iron piece is designed to weigh 7-9 kg for easy use in all furnaces and cupolas. We meet customized Pig Iron requirements by undertaking special-grade production. Our SG (Spheroidized Graphite) grade of Pig Iron is especially highly sought-after.

**The India metal casting market size reached US\$ 12,473 million in 2023. Looking forward, the market is expected to reach US\$ 21,252 million by 2032, exhibiting a growth rate (CAGR) of 5.8 percent during 2024-2032.**

**KFIL leadership team envisaged India's upgradation from Euro 3 to Euro 6 vehicle emission standards and the constant change in the design of the vehicle and engine and, thereby, the change in the designs of casting as a continuous effort of new product development. With the same insight, we entered the industry with cylinder blocks and heads, tractor housing, and other solutions and moved closer to the raw material, the iron ore.**

The delivery of our product is as important as its manufacturing. That's why we fulfill customer requirements accurately with heat-wise stacking and loading of material. A key to this division is our emphasis on making the process of Pig Iron purchase more customer-friendly through enhanced delivery service, the best logistics network, and exclusive service providers.

**Kindly share your views on India's position in the global Foundry and Automotive industries?**

China has reported 54.05 million tonne of castings with 12.49 million tonne approximately. India is the second largest producer of castings. Nearly 5,000 foundries in India of which about 85 percent are small units, 10 percent are medium-sized and 5 percent are large, organized foundries. Of the bulk castings produced by Indian foundries, the largest chunk is that of grey cast iron, followed by ductile cast iron, steel, and non-ferrous alloys.

The India metal casting market size reached US\$ 12,473 million in 2023. Looking forward, the market is expected to reach US\$ 21,252 million by 2032, exhibiting a growth rate (CAGR) of 5.8 percent during 2024-2032. The global metal casting market size was estimated to be worth US\$ 24,1460 million in 2022 and is forecast to a readjusted size of US\$ 34,0580 million by 2028 with a CAGR of 5.9 percent during the review period.

The global demand for castings has been on the rise in recent years. European countries and the US are gradually coming out of the economic slowdown, and are looking to outsource some of their castings manufacturing requirements. The Government of India is trying to propel the economic growth of the

**"As a leading Pig Iron manufacturer in India, we have developed a reputation for consistency in quality, delivery, and service. We focus on creating the ultimate value and convenience for the customer in everything that we do."**

**RV Gumaste  
Managing Director  
Kirloskar Ferrous Industries  
Ltd (KFIL)**

country by boosting exports. The new manufacturing policy envisages raising the share of manufacturing in the GDP to 25 percent. As foundry castings are an integral part of most engineering manufacturing processes, the role of Indian foundries is a very important part of this strategy. While India may be behind China as far as overall castings exports are concerned, it is the second-largest producer of castings globally. Understanding the need to be competitive, the Government of India is also modifying its policies so that the import of raw materials and export of castings is easier. This should boost casting exports from India.

India's foundries are actively upgrading their facilities and technologies to enhance productivity and expand capacity, responding to escalating demand.

The Automotive sector is the main driver of foundries. About 60 percent of metal castings are for the Automotive sector, followed by Railways, Machine Tools, Defence, Aerospace, Sanitary Fittings, etc.

A decade ago, KFIL decided to shift from normal casting solutions to meet the requirements of international and MNC clients who were already working

with the Euro 6. It was a challenging process as it required new technology, new processes, and improved competencies of the people in the manufacturing area. Today, the brand is internationally known for the Euro 6 large castings. Another hurdle that the KFIL team successfully surmounted was the high investment required for the technology. Despite the capital-intensive nature of the foundry, the decision to adopt a new technology was difficult to make as it required altering the process and the people's skills and competencies.

**Are there any initiatives or investments in the pipeline to adopt automation and advanced manufacturing techniques in the processes?**

KFIL has undergone a significant transformation, with technology playing a crucial role as the brand upgraded its technology and embraced automation. As the industry transitions to Euro 6 standards, requiring thinner and more complex castings, and with auto parts being integrated into castings, we must increase our capacity and expertise in various casting technologies while maintaining a proactive mindset to adapt to these changes.

We are working toward backward and forward integration. KFIL has recently set up a coke oven plant and power plant (waste heat recovery plant) at an investment of INR 600 crore. This initiative by the brand will lead to reduced importing of metallurgical coke as it will manufacture the coke.

Another positive step undertaken in the manufacturing process is the generation of 40 megawatt of power used in the foundry which eventually becomes a cost-reduction project for the brand. Apart from this backward integration, we have

“As one of India’s largest engineering companies, we, the Kirloskar Group, believe we have a responsibility towards our customers and the country to keep addressing the needs of our times and strive to transform as many lives as possible. In the process, we transform ourselves as well.”

**RV Gumaste**  
Managing Director  
Kirloskar Ferrous Industries Ltd  
(KFIL)



Source: KFIL

also embarked on forward integration by starting machine shops in Solapur and Koppal to offer machined castings to clients. The endeavor is to transition the raw material from iron ore mining to iron castings within 24 hours, a unique business model to set us apart from the rest.

KFIL foundries are equipped to produce Grey Iron Castings weighing from 30 kg to 300 kg. These castings are used to manufacture heavy, medium and light commercial vehicles, SUVs, tractors, construction equipment, and industrial engines through a robotic core center.

In the Proto Casting business, to fulfill customer requirements for rapid prototype castings, KFIL has decided to reduce the new product development (NPD) time by setting up a 3D Core/Mold printing facility in the Koppal Plant.

**Kindly highlight any sustainable practices or environmental efforts undertaken by KFIL in line with global trends.**

Our sustainability framework is a set of principles and standards that are used to measure and manage our environmental, social, and governance (ESG) performance. Our environmental strategy focuses on continuously

optimizing our existing processes and systems while also proactively implementing more efficient processes for new operations.

**Some notable initiatives include:**

The installation of the Blast Furnace Top Pressure Recovery Turbine (BLT) is expected to lower coke consumption by approximately 15 kg per tonne of hot metal (THM). This implementation offers a tangible benefit in terms of improved energy management within the system.

We have invested prudently in the adoption of renewable resources, primarily solar power generation, to promote green energy and reduce carbon footprint. We have installed a 10 MW solar plant and are planning for an additional 20 MW plant. Solar energy is a sustainable and clean source of power, enabling us to conserve energy and contribute to a greener future.

We have significantly improved energy management within the production process, reducing specific energy consumption. This achievement can be attributed to the installation of Variable Frequency Drives (VFDs) at power plants. We have also incorporated energy-efficient Low Tension (LT) motors,

further bolstering our efforts to lower power consumption.

In addition to solar power, we also focus on waste heat recovery as an alternative to generating energy while minimizing our environmental impact. Our plant effectively captures waste heat from the coke oven and blast furnace processes. The waste heat, from the coke oven and blast furnace, is used to generate steam in our waste heat recovery boilers. The steam, in turn, drives turbines for power generation of 51.5 MW.

We have implemented several initiatives to mitigate air emissions. The efficiency of these initiatives is being assessed by the National Accreditation Board for Testing and Calibration Laboratories (NABL). Additionally, we have installed online environment monitoring stations for monitoring of Sulphur Oxide (SO<sub>x</sub>), Suspended Particulate Matter (SPM), Carbon Monoxide (CO) and Nitrogen Oxide (NO<sub>x</sub>) emissions to ensure that they are within the permissible limits. We have installed bag filters in our power plants to control emissions. These filters restrict the release of pollutants into the atmosphere, aligning with our commitment to responsible air emission management.

We have also undertaken tree plantation activities within plant premises in all three locations and its surrounding areas. This initiative aims to enhance green cover and shape a cleaner future.

We have taken well-thought-out measures to maintain air quality by implementing pollution control equipment at the necessary locations. This includes the installation of dust extraction systems and the use of porous mesh and tall plantations along our premise's perimeter to prevent the release of dust and noise outside our company grounds. 

**The Automotive sector is the main driver of foundries. About 60 percent of metal castings are for the Automotive sector, followed by Railways, Machine Tools, Defence, Aerospace, Sanitary Fittings, etc.**

# MADE IN INDIA FOR THE WORLD

At the recently concluded IMTEX FORMING 2024 & Tooltech 2024, Indian Machine Tool Manufacturers' Association (IMTMA) acknowledged four companies for their significant contribution towards bolstering India's export prowess and showcasing the country's capabilities on the global stage with the highly coveted 'IMTMA Export Performance Award'. The chosen companies include IND-Sphinx Precision Ltd, ISGEC Heavy Engineering Ltd, ITL Industries Ltd, and Jyoti CNC Automation Ltd.

## IMTMA Export Performance Award 2024



ISGEC Heavy Engineering Ltd received the award in Metal Forming Manufacturer Category



Jyoti CNC Automation Ltd received the award in Metal Cutting Manufacturer Category



IND-Sphinx Precision Ltd received the award in Sub-System / Accessories Manufacturer Category



ITL Industries Ltd received the Jury Appreciation Award

Source: Magic Wand Media

SOUMI MITRA  
Editor-in-Chief  
Modern Manufacturing  
India  
soumi.mitra@  
magicwandmedia.in



**I**n a comprehensive overview of the four companies' export strategies, product offerings, market reach, and customer support initiatives, we delve into the intricacies of India's thriving machinery export sector.

### Global perception of Indian-made machines

The perception of international

buyers towards Indian-made machines has been evolving rapidly. They are garnering increased attention for their quality, reliability, and cost-effectiveness. Mihir Baxi, President, Global Sales, Jyoti CNC Automation Ltd, says, "India is now being considered globally for the reliability and technical superiority of products developed and manufactured within the country."

For Ronuk Taneja, Director, IND-Sphinx Precision Ltd, the outlook of international buyers towards Indian brands is changing for the better. "From being perceived as a low-cost manufacturing country, today India is looked upon as a destination for providing high-quality products at competitive prices. As an Indian manufacturer, we offer cost-effective solutions without

“The ‘Make in India’ initiative, improvement in quality, ease of doing business, stable government and strong government support, technological advancement, etc. have made positive changes in the mindset of international buyers and has led to the acceptance of India as a manufacturing destination for high-tech, high-quality machines.”

**Mihir Baxi**  
**President, Global Sales**  
**Jyoti CNC Automation Ltd**



compromising on quality, making high-standard tools attractive to buyers seeking value for money. Moreover, India is seen as a stable global partner in today’s volatile world,” he asserts. In alignment, Yogesh Saxena, Chief Executive, Machine Building Division, ISGEC Heavy Engineering Ltd, shares that ISGEC machines are designed and manufactured to meet international standards. He highlights, “With our unwavering focus on both customization and reliability, ISGEC empowers customers to achieve their production goals efficiently and effectively,

bolstering their competitiveness in the global market.”

Taking pride in sharing the customers’ names, Saxena says that the company has a long list of loyal international customers who place repeat orders regularly. To name a few, ISGEC caters to Valeo, France; LuK, Germany; Farguell, Spain; Azpiaran, Spain; Amvian, USA; Big Rapids, USA; Benteler, Germany, etc.

**Customer-centric approach**

Sharing Jyoti CNC’s long-standing experience in the international market, Baxi explains that the ‘Make in India’ Initia-

tive, improvement in quality, ease of doing business, stable government and strong government support, technological advancement, etc. have made positive changes in the mindset of international buyers and has led to the acceptance of India as a manufacturing destination for high-tech, high-quality machines. He elaborates, “Jyoti’s products find application in various end-user industries such as Automobile, Aerospace, Allied Machinery, Die and Mold, Diamond, Defence Medical Equipment, Plastic Processing, and Textile Machinery industries.”

According to a IMTMA report, the machine tool exports from India in the first half of FY24 was INR 716 crore (US \$87 million), showing a flat rise of 2 percent.

**Exported Products of Jyoti CNC Automation Ltd**

**DX Series:** Entry-level 2 Axis CNC turning machines

**VMC Performance Series:** High-performance C-Frame 3 Axis milling machine centre

**Tachyon Series:** Meets the demand for fastest drill-tap in various industries

**ATM Series:** Vertical line series machines with inverted spindle and automated job feeding feature

**AX Series:** High precision turning/turn mill series with Y axis and sub-spindle features

**NX Series:** Double column VMC

**TS Series:** Twin spindle-Twin Turret turning machine with gantry robot

**TMX Series:** Multitasking machines with secondary spindle and dual turret for simultaneous machining.



The top three machinery types exported from April to November 2023, valued at INR 428 crore (US \$52 million), were lathes (17%), vertical milling machines (15%), and horizontal machining centers (HMC) (10%). This accounted for over 43 percent of the total machine tool exports.

“From being perceived as a low-cost manufacturing country, today India is considered a destination for providing high-quality products at competitive prices. As an Indian manufacturer, we offer cost-effective solutions without compromising on quality, making high-standard tools attractive to buyers seeking value for money.”

**Ronuk Taneja**  
**Director**  
**IND-Sphinx Precision Ltd**



Saxena highlights technological advancements, customization and flexibility, strong engineering expertise, and global partnerships as additional key interest areas for international buyers. “ISGEC is at the forefront of technological innovation in the Manufacturing industry. Our commitment to advancing technology is evident through continuous research and development efforts. Our separate R&D Center is dedicated to exploring and implementing cutting-edge technologies in press solutions to address the emerging needs of the industry,” he shares. ISGEC’s pool of highly experienced engineering talent, along with renowned global chief design consultants in the press solution industry working with the company, ensures the design and production of high-quality machines. “ISGEC engages in partnerships and collaborations globally with its business associates to enhance market reach and competitiveness specific to the customer’s local market,” he adds.

**Global reach**

The demand for precision machinery transcends borders, with manufacturers catering to diverse markets across the globe. Taneja gives an insight into the company’s expansive reach, stating, “We export to 35 different countries, with a focus on leading technological hubs like Germany, Switzerland, Japan, and the United States. We provide precision cutting tool solutions tailored to the exacting standards of these markets. By serving these key regions, we contribute to the advancement of manufacturing technologies worldwide, establishing ourselves as a preferred supplier of high-performance machining tools on the international stage.” Highlighting Jyoti CNC’s widespread global presence, Baxi states, “With installations in over 60 countries like Germany, France, and many other countries across Europe, Canada, South Africa, Singapore, Mexico, Turkey, Middle East countries, Vietnam, Thailand, Indonesia,

and the Philippines, we are present in the key markets with significant installation density.” Rajendra Jain, Managing Director, ITL Industries Ltd, recollects the days when the company just stepped into exports around three decades ago. “Initially, we faced challenges, displaying our machines at international fairs like Hannover Germany and IMTS Chicago (in the years 1996, 1998, and 2000), and did not achieve much success. Our approach of selling directly to end-users wasn’t effective in the global market, where distributors and dealers play a crucial role as intermediaries and are the real link.” In 2014, a breakthrough occurred when a distributor from the USA took an interest in ITL Industries’ NC Carbide Circular Saw Machine during the Shanghai Show. Recognizing its potential, the distributor proposed to sell ITL Industries’ machines through their network in North America and Europe, areas where NC Carbide Ma-

**Exported Products of IND-Sphinx Precision Ltd**

**High-Precision Cutting Tools:** Specializing in a wide range of tools, including drills, end mills, ball nose end mills, PCB drills, PCB routers, reamers, engravers, and customized tools tailored for precision machining applications.

**Microtools:** Focus on microtools with the smallest tool manufactured being 15 microns in diameter, catering to industries such as aerospace, defense, automotive, medical, and more.

“ISGEC is at the forefront of technological innovation in the manufacturing industry. Our commitment to advancing technology is evident through continuous research and development efforts. Our separate R&D Center is dedicated to exploring and implementing cutting-edge technologies in press solutions to address the emerging needs of the industry.”

**Yogesh Saxena**  
**Chief Executive, Machine Building Division**  
**ISGEC Heavy Engineering Ltd**



chines were not part of their product portfolio. “We agreed to the distributor’s condition of selling under his brand name, marking the beginning of our export journey in 2016. Presently, we export NC Carbide Circular Saw Machines and Band Saw Machines to North America, European Union, Russia, UK, and Australia,” informs Jain. Elaborating on ISGEC’s global footprint, Saxena says, “We export our advanced mechanical press solutions to key markets around the world like Germany, USA, Spain, Hungary, Slovakia, Poland, Czech Republic, China, South Africa, France, Brazil, Iran, Thailand, Indonesia, Vietnam, etc.”

**Extending support and hand-holding**

Emphasizing the importance of after-sales service and support, Jain says that though erection commissioning and after-sales service support is the responsibility of the distributor/dealer, ITL Industries trains the customers’ technical teams at the company’s facilities in Indore. For special-purpose machines, ITL Industries sends its technicians to the customer’s site at its own cost. This approach ensures that customers receive prompt and effective support, wherever they are. Outlining the company’s approach to lending technical

support for its international customers, Saxena shares, “We have dedicated technical support teams equipped with extensive knowledge and expertise in our products and solutions. These teams serve as primary points of contact for international customers, offering prompt and personalized assistance to address any technical inquiries or issues.” Additionally, ISGEC has a strong global network of service partners locally located in key regions to ensure timely and efficient support to its international customers. According to Saxena, these service partners employ skilled technicians and engineers, trained in ISGEC prod-

**Machine tool exports during CY2023 from India reported an 8 percent growth, amounting to INR 1,543 Cr (US\$ 185 M) and consumption is estimated to have increased by 13 percent to reach INR 25,283 Cr (US\$ 3 B) in CY2023.**

**Exported Products of ISGEC Heavy Engineering Ltd**

**Automated Tandem Line Mechanical Presses** (MAT Series: 315T to 2500T) - High productivity in tandem operations with Robotic Automation

**Transfer Mechanical Presses** (MATR Series: 630T to 3150T) - Seamless part transfer and high-volume production capability

**Progressive Die Mechanical Presses** (MAP Series: 315T to 1250T) - Versatile and reliable in progressive die applications

**Servo Mechanical Presses** (MAS Series: 315T to 3150T) - Integrates advanced servo-driven systems for precise and efficient operations

**Straight Sided Standalone and Gap Frame Mechanical Presses** - Used to produce small to medium stamping parts



For exports, Russia (29%), China (9%), and the USA (9%) emerged as the top three export destinations, accounting for 47 per cent of total machine tool exports from April to November 2023 with a total export value of ₹1,005 crore (US \$121 M) and 4,515 units of machines exported.

“Presently we export NC Carbide Circular Saw Machines and Band Saw Machines to North America, European Union, Russia, UK, and Australia. Our distributors sell ITL machines in their own established brand names.”

**Rajendra Jain**  
**Managing Director**  
**ITL Industries Ltd**



ucts, to troubleshoot and resolve technical issues quickly and effectively. They also have the necessary equipment to install the company's presses and offer prompt service to customers. For remote technical assistance, he states, “We use modern communication technologies to provide remote technical assistance to our international customers. Through phone, email, video conferencing, and remote desktop support, our technical experts can offer real-time guidance and troubleshooting assistance to resolve technical challenges and optimize machine performance.” “For on-site issues, we send our qualified service engineers to the customer's location to pro-

vide hands-on support and maintenance services. Our experienced service engineers along with local partners in the specific country, who are equipped with the necessary tools and equipment, address complex technical issues and ensure minimal downtime for our customers,” he mentions.

In sync, Baxi shares that after-sales support is highly crucial to ensuring smooth performance of the machines. The company follows the below steps to ensure support for international customers:

**Local Presence** - Jyoti CNC's dealers and sole selling agents appointed in respective countries have Jyoti-trained engineers and service setups with the required spares. For any critical technical assistance, the company's engineers from India visit the customer. For the initial commissioning of higher-end machines, Jyoti CNC deputizes its trained engineers in the majority of the cases.

**Proprietary Software** - Each Jyoti machine is equipped with special proprietary software developed by the company. The software '7th SENSE' allows each machine to get connected to the company's server through the Internet for remote diagnosis of the problem online.

**Online Support System** - Jyoti has an online support system

to support customers 24x7 for remote diagnosis of their machines through trained engineers, extending all necessary help and assistance online.

Ensuring technical and after-sales support for international customers involves several key strategies. To this, Taneja adds, “It is very important to establish a network of authorized service partners in different regions. Our distributors stock and sell our tools and provide technical support to customers. Often, the distributor's technical staff visits the company for product-related training that equips them to support local customers.” He continues, “Our application team also visits customers along with the distributors in case there is a need for support. In Europe, we have our own subsidiary for stock, sales, and providing technical support for our products.”

**Machining the future**

In conclusion, as India strides forward as a global manufacturing powerhouse, the Machine Tool industry stands at the threshold of remarkable growth. Bolstered by initiatives like 'Make in India' and supported by advancements in quality standards and ease of doing business, Indian-made machines are gaining increased traction among international buyers. 

**Exported Products of ITL Industries Ltd**

- NC Carbide Circular Saw Machines
- Band Saw Machines





Indian Machine Tool  
Manufacturers' Association



Manufacturing Technology  
Training

An IMTMA initiative

# Enhancing Manufacturing Industry Competitiveness

## Upskilling Young Engineers and Industry professionals

200+ Focused Technical Training Programmes on



For further details, please contact:

Ph : +91 9886331231

E - Mail : [training@imtma.in](mailto:training@imtma.in)

W: [www.imtmatraining.com](http://www.imtmatraining.com) | [www.imtmaelearn.in](http://www.imtmaelearn.in)



# SETTING NEW STANDARDS

At the new CERATIZIT production plant in Kreckelmoos, two KNOLL central cooling lubricant filtration systems reliably supply hundreds of grinding machines with oil and aqueous solution – perfectly cleaned and precisely tempered to  $\pm 0.2$  Kelvin. This enables the tool specialists to achieve the highest quality and efficiency when grinding and cutting carbide rods and indexable inserts.



Source: KNOLL Maschinenbau GmbH

Central cleaning system for aqueous solution: The strengths of the MicroPur® system start with the installation area. Compared to conventional filtration systems, only around 60 percent of the space is occupied with the same throughput volume.

**C**ERATIZIT has a clear goal in mind: “We want to become the world’s number 3 in the carbide industry”. The company, which is part of the Plansee Group, is not only continuing to drive growth in Asia and on the American continent, progress is also being made at CERATIZIT Austria in Reutte – at the headquarters of the parent company. In the Kreckelmoos district of Breitenwang, just a few hundred meters up from the existing company headquarters, an additional production plant has been built that sets new standards in many respects.

The three-storey building has a total area of around 38,000 sq mt and offers production halls of various sizes, storage and logistics areas, offices, and social spaces for around 500 employees. The production facility has just over 15,000 sq mt at its disposal, around two-thirds of which is currently being used. Tobias Raggl, Head, Technology Department, CERATIZIT Austria and client representative for the new building, explains, “At our Reutte site, we produce carbide and machine it into indexable inserts, rods, and molded parts. The new building has enabled us to separate the carbide production,

including pressing and sintering and the machining of hardened blanks, and create growth opportunities for both areas.” From January to December 2023, CERATIZIT Austria relocated around 220 large machines from the lower plant to Kreckelmoos, primarily machines for grinding and cutting indexable inserts and rods. A special tour de force, as ongoing production was maintained. “Our aim was to have every machine up and running again after two days,” confirms Project Manager Raggl. “This required precise planning in terms of space and time.”

NIKHIL NAYAK  
Managing Director  
NN Combined  
Engineering Agencies  
Pvt Ltd



Source: KNOLL Maschinenbau GmbH



Thanks to the modular design, central cooling lubricant cleaning systems with MicroPur® filters can be realised in almost any size. This system for aqueous solutions offers a cleaning capacity of up to 7,500 litres/min of cooling lubricant.



Source: KNOLL Maschinenbau GmbH

Michael Müller is responsible for the maintenance of the cooling lubricant systems at CERATIZIT: "Changing the MicroPur® filter elements is simple, drip-free and can be done in a matter of minutes without having to shut down the entire system."

### CERATIZIT - Global player in the carbide industry

CERATIZIT offers sophisticated carbide solutions for machining and wear protection, highly specialized cutting tools, indexable inserts, and carbide rods. These products are used in areas such as mechanical engineering and toolmaking, the Automotive industry, the Aerospace industry, the Oil and Gas industry, and the Medical industry.

CERATIZIT Austria is located in Reutte/Tyrol, at the headquarters of the parent company Plansee Group. This is where carbides are mixed, pressed and sintered and carbide indexable inserts, rods and molded parts are produced.

### Indispensable: A central cooling lubricant supply

Those responsible paid partic-

ular attention to the supply of cooling lubricant to the machines, without which none of the machining systems could go into operation. "In our previous production, we had installed five central systems of different sizes from KNOLL Maschinenbau," reports Raggl. "After analyzing the market with regard to the technical possibilities and taking into account the experience we had gained over the years, we were absolutely certain that KNOLL was also the perfect partner for the cooling lubricant systems we needed in Kreckelmoos. The

KNOLL team, whether developers, planners or fitters, is a consistently competent and efficient partner who is aware that everything has to work perfectly for this new installation."

KNOLL is the leading provider of conveyor systems, filtration units, and pumps for metalworking. These transport and separate chips and cooling lubricants. The comprehensive product range offers systems for decentralized or centralized applications. Its Automation Division deals with solutions for challenging assembly and logistics tasks. These include stationary transport systems with chain and roller conveyors. The integration of handling units (robots, cobots) and transport robots (AGVs) enables flexible systems to be created from a single source.

Once the systems and the entire pipework system had been dimensioned, the order was placed in March 2022 and the cooling lubricant supply was ready for operation by the end of the year.

**KNOLL is the leading provider of conveyor systems, filtration units, and pumps for metalworking. These transport and separate chips and cooling lubricants. The comprehensive product range offers systems for decentralized or centralized applications.**



Tobias Raggl (left) and Anton Pfanner look at the purified aqueous solution that comes out of the filter crystal clear. It does not contain any particles larger than 3 µm or air bubbles.

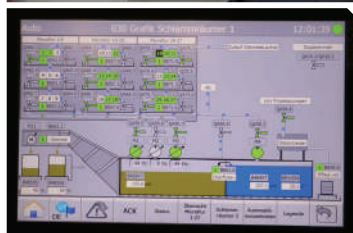

The control display provides a clear overview of the current data and filter curves of the central cleaning system.

### Two central systems - for oil and aqueous solution

As CERATIZIT Austria uses different cooling lubricants, oil and aqueous solution, the company decided in favor of two central systems, both of which are based on the KNOLL MicroPur®

In order to minimize the risk of germ contamination, KNOLL developed a sophisticated flow control system for the cooling lubricant so that there are no dead spaces in the MicroPur® modules or in the tanks where the medium could accumulate.



Source: KNOLL Maschinenbau GmbH



Source: KNOLL Maschinenbau GmbH

An important component of KNOLL filtration systems is the integrated automatic concentrator, which ensures that the carbide sludge ends up in the waste drum in a compact state. Growth prospects: The KNOLL MicroPur® system for oil filtration can be expanded to a capacity of 10,000 l/min.

ultra-fine filter system. They are made up of several MicroPur® modules, each with a cleaning capacity of 400 l/min. Each module is fitted with four filter housings, each containing two filter cartridges. These can be backwashed individually with pure medium without interrupting the filtration process – a key feature of the MicroPur® filter.

Over 70 systems are currently operated with oil at the CERATIZIT plant in Kreckelmoos. These are mainly machines for surface, peripheral, and profile grinding of indexable inserts and for vibratory grinding in tool-making. The central system installed for this purpose contains 15 MicroPur® modules, so that over 5,000 l/min can be cleaned continuously. To cope with the growth, the system can be expanded to 27 MicroPur® modules, doubling the total capacity to around 10,000 l/min.

#### Reliable and powerful

Anton Pfanner, Maintenance Group Manager, is responsible for the operation of the two KNOLL cooling lubricant systems. He knows that he does not need to worry about their functionality: “All pumps and other important components are redundant. Only a power failure can actually cause an unplanned stop.”

He is also very familiar with the performance of the KNOLL systems at the previous plant. Although the oil system there was slightly smaller with a maximum flow rate of 2,400 l/min, the achievable values are identical. “The filter fineness range is between 1 and 3 µm, and the cleaned oil has a gravimetric residual dirt content of just 1 mg/l,” says the Maintenance Group Manager happily. This purity not only results in optimum machining results, it also prevents wear on the machine bed guides and high-pressure pumps.

#### Problem areas of the aqueous solution under control

CERATIZIT Austria uses an aqueous cooling lubricant solution for centerless grinding and cutting carbide rods. “This is the only way to achieve the desired mirror finish,” argues Technical Manager Tobias Ragg: “Water dissipates heat much better than oil, which breaks down under high pressure during centerless grinding. That’s why we have to stick with water, even if we would like to use oil as the only medium.”

The aqueous cooling lubricant solution is a concentrate that usually consists of polymers or salts dissolved in water and, unlike emulsions, is free of mineral oil. A major problem is that the

medium becomes charged with micro-air during the machining process, which hinders filtration. In addition, the aqueous solution requires a very constant temperature for perfect machining results and must be constantly flowing to prevent contamination by microorganisms and fungi.

KNOLL designed its MicroPur® filter to be ‘water-compatible’ for cleaning such cooling lubricant solutions. This means that the developers customized the filter fabric and module housing to the special requirements. The backwash was modified and process sequences reprogrammed. Two of the first water-compatible MicroPur® modules were installed at CERATIZIT Austria in 2017. They were part of a KNOLL central system in which hydrocyclones removed the coarse impurities and the MicroPur® filters in the bypass removed the fine impurities.

#### All areas of concern under control

Inspired by the success of this microfiltration, those responsible decided to switch to full filtration of the aqueous solution with MicroPur® modules at the Kreckelmoos plant. This central system can hold a maximum cooling lubricant volume of 1,50,000 l and

Source: KNOLL Maschinenbau GmbH



MicroPur® modules are equipped with four filter housings, each containing two filter cartridges. The cleaning capacity per module is 400 l/min.



Source: KNOLL Maschinenbau GmbH

The five KNOLL process pumps for the aqueous solution system can be seen in the foreground. They pump the cleaned medium back to the machines as required. In the background are the three somewhat smaller filter pumps, all of which are frequency-controlled.

Carbide indexable inserts require ever greater precision and surface quality, which places high demands on the grinding process and the cooling lubricant.

can clean up to 7,500 l/min with its 27 MicroPur® modules.

As of December 2023, 85 machines were connected for centerless grinding and cutting the carbide rods, with sufficient filter capacity for a further 85 machines. "We therefore did not fill the system completely," says Anton Pfanner, Maintenance Group Manager. "However, the MicroPur® units are usually all in operation, as the system automatically controls their use depending on the machines switched on and the flow rate."

Pfanner is aware of the problem areas of the aqueous solution mentioned above. "But the experience gained from the partnership with KNOLL and the close cooperation with regard to further developments in solution filtration have justified the decision in favor of MicroPur® cleaning at full flow," says Pfanner.

In order to minimize the risk of germ contamination, KNOLL developed a sophisticated flow control system for the cooling lubricant so that there are no dead spaces in the MicroPur® modules or in the tanks where the medium could accumulate.

There are, therefore, no deposits that promote the growth of germs. In order to banish the micro-air almost completely from

the aqueous solution, KNOLL designed a relatively long, flat degassing section through which the cooling lubricant must pass. And to keep the temperature of the cooling lubricant stable, it passes through a cooling system immediately after filtering, which ensures values of  $\pm 0.2$  K. Last but not least, the aqueous solution itself is of great importance. "In recent years, we have carried out extensive tests with our additive supplier and KNOLL in order to achieve the best results in cleaning and machining," reports Pfanner. "We have actually succeeded in reducing the additives to a single additive that realizes all the desired properties of the solution. It contributes to rapid degassing, improves the friction conditions, provides rust protection, and counteracts the release of heavy metals such as cobalt."

#### Central cooling lubricant supply systems - a complete success

"The processes and transparency during installation, the rapid support when questions arise and, finally, the cooling lubricant qualities that our new central systems deliver, fully confirm our trust in KNOLL," summarizes Raggl. "The system runs great -

down to the last detail."

This also includes the extremely effective desludging system, which, in addition to sedimentation in the dirt tank, includes an automatic concentrator that also separates the carbide backwashed out of the filter cartridges. Pfanner explains: "We recover around one drum containing 400 kg of carbide per month from the oil plant. In the case of the aqueous solution, there are currently around four such drums, which is due to the larger dimensions. We send the grinding sludge to our sister company Stadler Metalle in Türkheim. After processing, the recycled carbide is reused by us." When asked about the overall maintenance effort, Michael Müller, the responsible maintenance employee, replies: "The systems are relatively low-maintenance. Filters need to be changed every six to twelve months, depending on the load. It only takes a few minutes to replace the filters. Other tasks include changing the grinding sludge drums and regularly checking the cooling lubricant values." If system faults occur, they can be recognized very quickly on the control display so that Müller can initiate countermeasures immediately. 

In order to banish the micro-air almost completely from the aqueous solution, KNOLL designed a relatively long, flat degassing section through which the cooling lubricant must pass. And to keep the temperature of the cooling lubricant stable, it passes through a cooling system immediately after filtering, which ensures values of  $\pm 0.2$  K.

# EMBRACING AUTOMATION FOR UPPING PRODUCTIVITY

Toyota Kirloskar Auto Parts Pvt Ltd (TKAP) brought in productivity improvement in the transmission machining line through in-house low-cost automation. Other advantages followed, justifying the much-needed change.

## Toyota Philosophy (Concept):

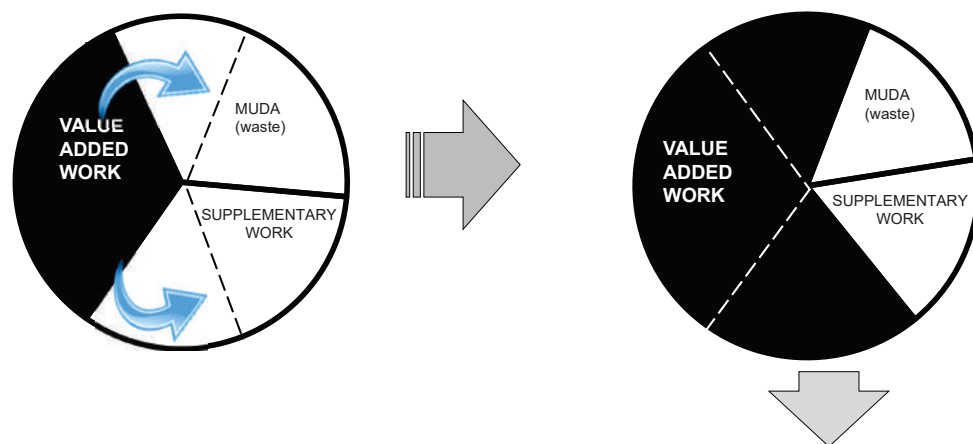

Image 1  
Effective utilization of manpower: Increase value-added work by reducing muda (waste) and supplementary work for productivity improvement

Source: Toyota Kirloskar Auto Parts Pvt Ltd

Today's market is characterized as being volatile and uncertain due to fluctuating customer demand. Hence, it becomes crucial for the Automobile industry to make wise investments in new projects and enhance flexibility to include changes. The proposed theme of Productivity Improvement showcases a case study where investment in new projects has been reduced while enhancing the flexibility of the production line through in-house developed parts conveyance system, which features internally developed AGVs (Automatic Guided Vehicles) and Karakuri methods—a Japanese technique to achieve simple

and low-cost movements for enhancing productivity and reducing headcount.

### Project triggers

Factors that influenced the project include (refer Image 2)

**Internal** - Increasing cost competitiveness among affiliates and year-over-year rise in labor costs.

**External** - Fluctuating market conditions (Government regulations), shifts in customer demands (hybrid/electric vehicles), and intense competition.

At Toyota, our approach is to 'increase value-added work and reduce supplementary and non-value-added work', effectively utilizing manpower. However, in practical scenarios,

most manpower is consumed for non-value-added tasks, particularly in the parts conveyance system.

As the project progressed, we noticed that dedicated manpower was being utilized to transport raw materials/parts in bins from the warehouse to the manufacturing line using tow motors and manual dollies, leading to conveyance muda (waste of transportation) and operator fatigue.

A study was conducted to implement automation solutions, tailored to our specific requirements, aimed at enhancing productivity (reducing manpower and investment, in alignment with our objectives).

NIRANJAN MR  
Manager  
Toyota Kirloskar Auto  
Parts Pvt Ltd (TKAP)  
niranjan@tkap.co.in



## What is TKAP's Low Cost Automation (LCA) – TKAP Definition..?

A System for Effective utilization of Manpower capabilities, developed at Lowest cost where Man & Machine can collaborate & work together to meet Toyota Way expectations.

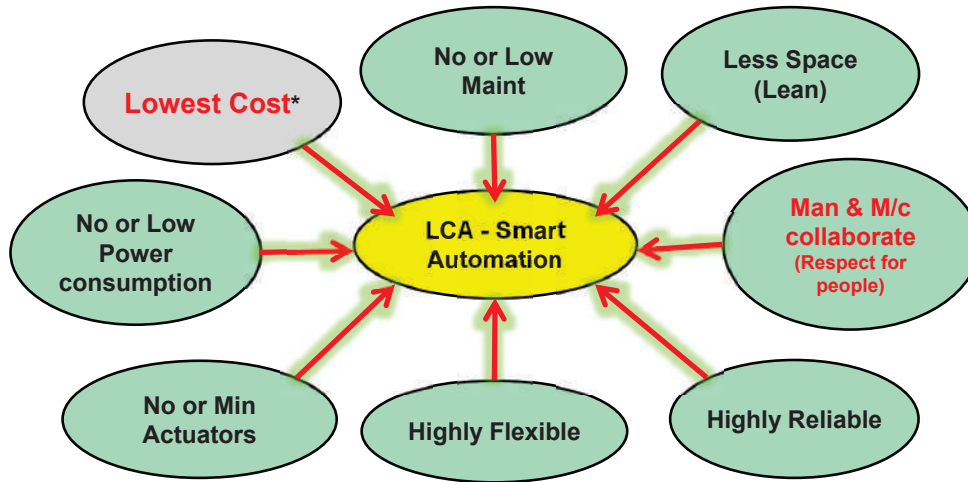

Image 3

SMART – What is required, when is required & How much required...

\* Its not only Cost which matters (Cost is only an end result)...

Source: Toyota Kirloskar Auto Parts Pvt Ltd

The decision was made to utilize in-house resources and their expertise and experience to develop an LCA (Local Conveyance Automation) project to meet the target (TKAP's LCA tools).

### Key concerns

- Implementing general automation not only presents cost-related challenges in terms of Return On Investment (ROI), but also has difficulties in terms of safety, environmental impact, flexibility, and lead time.
- Kaizens need to be incorporated from the project's inception to realize the benefits from the very first day of line off.
- Demonstrating cost competitiveness with other affiliates is crucial, as there is always competition to secure the project. This has, therefore, triggered a parts conveyance automation project to enhance productivity and reduce manpower.

### Solution generation, innovation and complexity

Initially, various outsourced measures were evaluated to meet the target.

- **Automated overhead conveyors:** These had limitations such as high cost, longer lead

times, and extensive space coverage. They offered limited flexibility for future modifications and also incurred high maintenance costs.

- **Outsourced high-capacity AGVs:** They too proved to be a costly option and also required annual maintenance contracts (AMC) and additional conveyor automation.

Therefore, the decision was made to utilize in-house resources and their expertise and experience to develop a LCA (Local Conveyance Automation) project to meet the target (TKAP's LCA tools) (refer Image 3).

Finally, the in-house team proposed a concept to develop a high-capacity AGV with the capacity of towing raw materials/parts (weighing 1,000 Kg) supplied in bins from the warehouse to the manufacturing line without human intervention. The proposal was presented to management and with their approval and support, the innovative development of high-capac-

ity AGV commenced.

TKAP had previously gained experience in-house by developing low-capacity AGVs (ranging from 100 to 500 Kg) for parts conveyance. Although the journey of in-house AGV development posed challenges and initially consumed time, we took up the challenge of creating a more capable high-capacity AGV to be more cost-competitive and enhance productivity, with considerable potential for expansion. However, the more challenging part was yet to come as the proposed development of AGV will only serve the purpose of towing the dolly from one location to another location. The key challenge was also to develop a solution to automatically load and unload the parts from AGV dolly to manufacturing line side conveyors (the proposed concept of line side conveyors was automated and equipped with powered motors and chain drive) and eliminate any manual interventions. To meet this automatic load and unload requirements on AGV,

**To meet automatic load and unload requirements on AGV, the team technically proposed to use Toyota's Karakuri technique to develop lowpowered Karakuri pushers using a rope and pulley mechanism.**

the team technically proposed to use Toyota's Karakuri technique to develop low-powered Karakuri pushers using a rope and pulley mechanism (image 4). A proto was developed initially to build confidence and evaluate the needs. The same was showcased and a consensus was built with related stakeholders (MFG, MNT, PC) to reflect on PDCA. The developed proto gave us much more confidence in proposing to convert the line-side powered chain conveyors to free roller-based Karakuri chutes using a similar rope and pulley concept, thereby further simplifying the solutions, reducing the investments, and achieving the targets with lesser lead time (minimum bought out parts were used).

**Innovative solutions developed**

- **High-capacity AGV:** The developed high-capacity AGV was modular with the ease of interchangeability and the ease of backup. It had a bidirectional movement and a

higher capacity battery to cater to the full load for 2 shift operations. It was also Wi-fi-equipped to control traffic and communication with line side Karakuri chutes.

- **Free rollers conveyors with Karakuri drive:** The Karakuri pushers have a rope and a pulley. The auto slip concept is for pusher return movement. The pushers help in the flow of full and empty bins in double-deckers. Auto loading of empty bins onto AGV is enabled with an extended Karakuri pusher arm. These auto slip pushers detect overloads. Accumulation conveyors are enabled with Karakuri technology.
- **Intelligent part delivery concept:** Memory logic enables delivery locations with types of parts plus variants. QR code read ensures accurate stopping. Chute and AGV wireless communication enables load/unload status checks. The system works on a need-based approach.
- **Traffic management:** Traffic lights are used to control

AGV and other vehicle traffic control. Priority-based signaling is used for AGV and other AGV traffic control.

**Key challenges and countermeasures taken**

There were several challenges involved, including:

- **Ensuring the safety features of AGV:** We did not want to compromise on safety and, hence, resorted to measures such as implementing primary safety scanners for obstacle detection, incorporating secondary bumper stoppers, and also having two stoppers in all chutes (primary and secondary, per Toyota spec).
- **High-capacity drives & battery backup for AGV:** This challenge was addressed by setting technical parameters and specifications to meet targets, implementing an engineering approach to calculate the drive and battery capacity, and lastly, sourcing drive motors and batteries locally.
- **Backup in case of AGV failure (first-time attempt):** For which

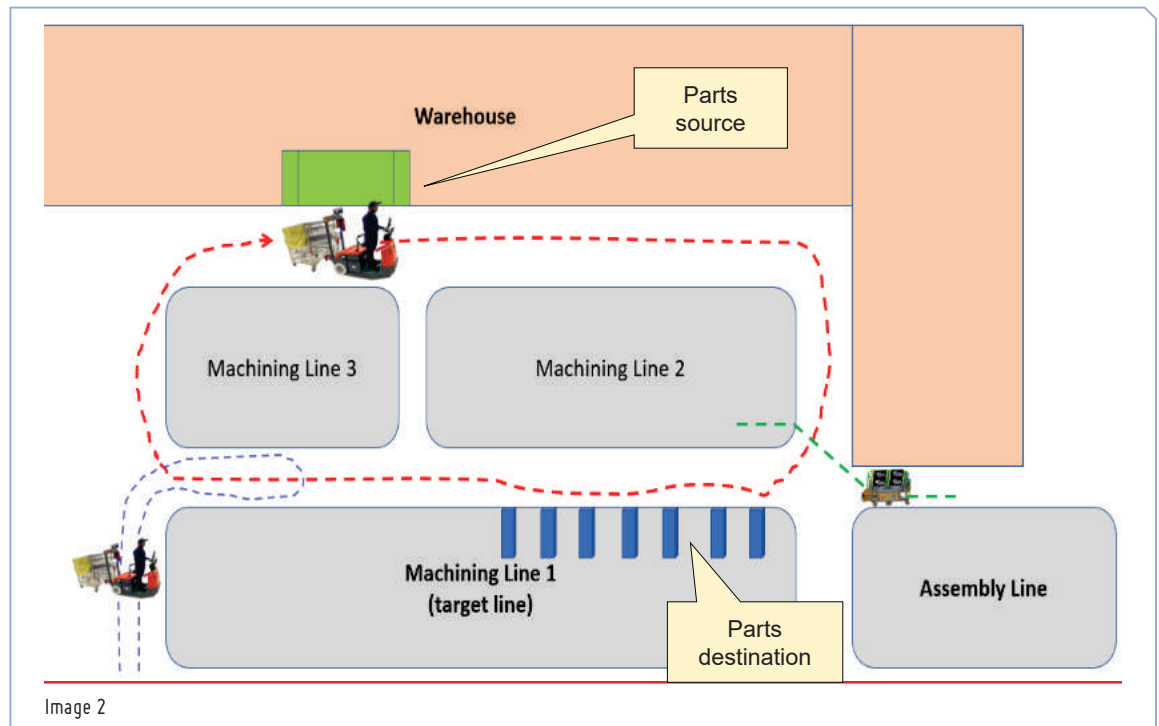

Source: Toyota Kirloskar Auto Parts Pvt Ltd

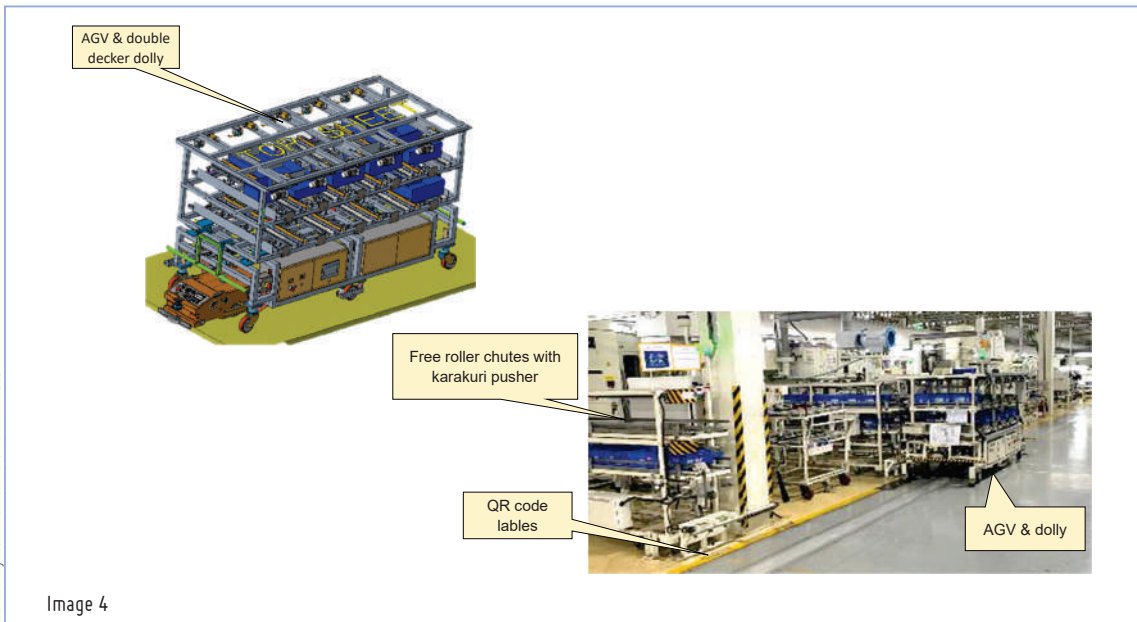

Image 4

a modular AGV design was introduced that allowed for extraction out of the dolly and manual operation of it.

- **Achieving AGV & dolly weight balance:** This required using a tubular chassis with a metal plate body for AGV and a tubular frame structure for the dolly, equipping AGV with friction wheels and the dolly with ergonomic and heavy-load swivel wheels.
- **Automatic parts transfer from AGV dolly to line conveyor & automatic receipt and feeding of parts in conveyor:** This required implementing free roller conveyors with Karakuri pushers with rope and pulley and also auto slip pushers for reverse and overload movement.
- **Interference with other lines leading to CT issues (long-distance travel):** This was addressed by changing the warehouse layout to be closer to the manufacturing line by involving stakeholders and optimizing AGV routes to reduce travel distances.
- **Balancing dolly to AGV length (where the length of dolly is significantly more than AGV):** To tackle the above, the mea-

sure enabled modular AGV movement inside the dolly guide, ensuring that AGV was always ahead).

### Green impact

In line with the Toyota Environmental Challenge 2050, Eco kaizens achieved include:

The batteries used in AGVs are Green Earth Batteries that cause the least harm to the environment and are also 100 percent safe in nature. The use of the Tow Motor Lead Acid battery, considered harmful to nature in the case of leaks, has been eliminated. Karakuri drives in chutes consume less energy (1/3rd) than the conventional type motor, chain drives.

### Result / Impact

- **The shop floor's overall safety has been enhanced:** There was earlier the risk of collision between tow motors and humans, which has been eliminated. Man-dependent risk management, which was subject to change has been replaced by system-based risk management. Non-explosive batteries with BMS have been introduced that do away with the risk of battery explosion.

High-torque actuators with direct drive have been replaced by low-torque actuators with a safety slippage concept.

- **Quality in terms of the right part being at the right location has been ensured:** There was human dependency and therefore, the risk of parts supply mix-up. Now because of the retentive memory logic in AGV, there cannot be parts supply mix-up.
- **Green initiatives have been enhanced:** Harmful Lead Acid batteries have been replaced by zero harmful green batteries. Also, now less energy gets consumed to charge batteries.
- **Productivity gained:** A reduction in headcount has been achieved.
- **Delivery has been improved with on-time supply:** The new system-based supply has led to zero dependency and, hence, no fluctuations. Travel time has also been optimized.
- **Investment cost has been reduced:** Earlier there would be costs such as tow motor and manpower costs. Now the AGV cost is less than the tow motor cost and also there is zero manpower.

The batteries used in AGVs are Green Earth Batteries that cause the least harm to the environment and are also 100 percent safe in nature. Acid battery, considered harmful to nature in the case of leaks, has been eliminated.

As we/Toyota India are upgrading our product line-up towards new technology like Hybrid and Electric vehicles, our production system also needs an upgrade from conventional to innovative solutions and automation.

Traffic signals  
(BMC: Railway signals)



Image 5

Source: Toyota Kirloskar Auto Parts Pvt Ltd

- **Running cost has been reduced:** A significant reduction in the running cost has been achieved due to the transition from outsourced tow motor annual maintenance contracts (AMC) to in-house AGV maintenance, zero yearly manpower costs, and reduced AGV battery charging expenses due to lower capacity requirements.
- **In-house skill levels have been enhanced (HRD):** There has been a transition from low-capacity AGVs and high-skilled tow motor driver dependency to the development of high-capacity AGVs in-house. This shift has been complemented by training and knowledge transfer to the Manufacturing and Maintenance teams, eliminating dependency on high-skill levels and enhancing motivation through the reduction of ergonomic burdens associated with tasks such as pushing/pulling and loading/unloading heavy objects.

#### Business sustainability

As we/Toyota India are upgrading our product line-up towards new technology like Hybrid and Electric vehicles, our production system also needs an upgrade from conventional to innovative solutions and automation, keeping in mind cost-competitiveness in the cost-sensitive Indian market. At Toyota India, we believe in growth through continuous improvement by adopting new technology for scale-up/expansion.

The below-mentioned TKAP's AGV's Roadmap and Karakuri Roadmap is a perfect example of continuous improvement through new developments and standardization for a scale-up.

- Skills of the in-house members were enhanced through the introduction of a new model
- The team was motivated to challenge themselves further with the next level of kaizens
- Deskilling was done by eliminating the dependency on highly skilled tow motor drivers

- TKAP's self-reliance enhanced through the development of automation solutions
- Adapted to new technology in production systems, including hybrid and electric vehicles.
- Carbon footprint and CO<sub>2</sub> emissions was reduced through automation
- Successfully secured 1 patent for innovation and uniqueness in the in-house developed 'AGV Drive Mechanism'.

#### Business metrics

- **TKAP production improvement through Karakuri and AGVs**
- **International Recognition for Karakuri:** Achieved the 'Global Best Idea Award' for three consecutive times at the Japan JIPM Karakuri exhibition
- **Reduction in new project investment achieved**
- **Proposed revenue generation model for AGVs:** Successfully completed a trial sale of 1 unit. 



Pune International Exhibition and Convention Center, Moshi, Pune

Delivered by IMTMA, organizer of **IMTEX**

**23-26**  
**May 2024**

The Region's Biggest  
**Machine Tool Expo**

**BOOK YOUR STALL NOW**

Co-located Show



Special Pavilions



Organiser



Media Partner



[mtx.co.in](http://mtx.co.in)



# DIGITAL TWIN: THE DOORWAY TO SMART MANUFACTURING

Kennametal's digital twin solution helps customers visualize the complete machining operation in a virtual setting with the right process parameters so that issues or adjustments can be addressed in the planning stages as opposed to later, potentially halting operations.

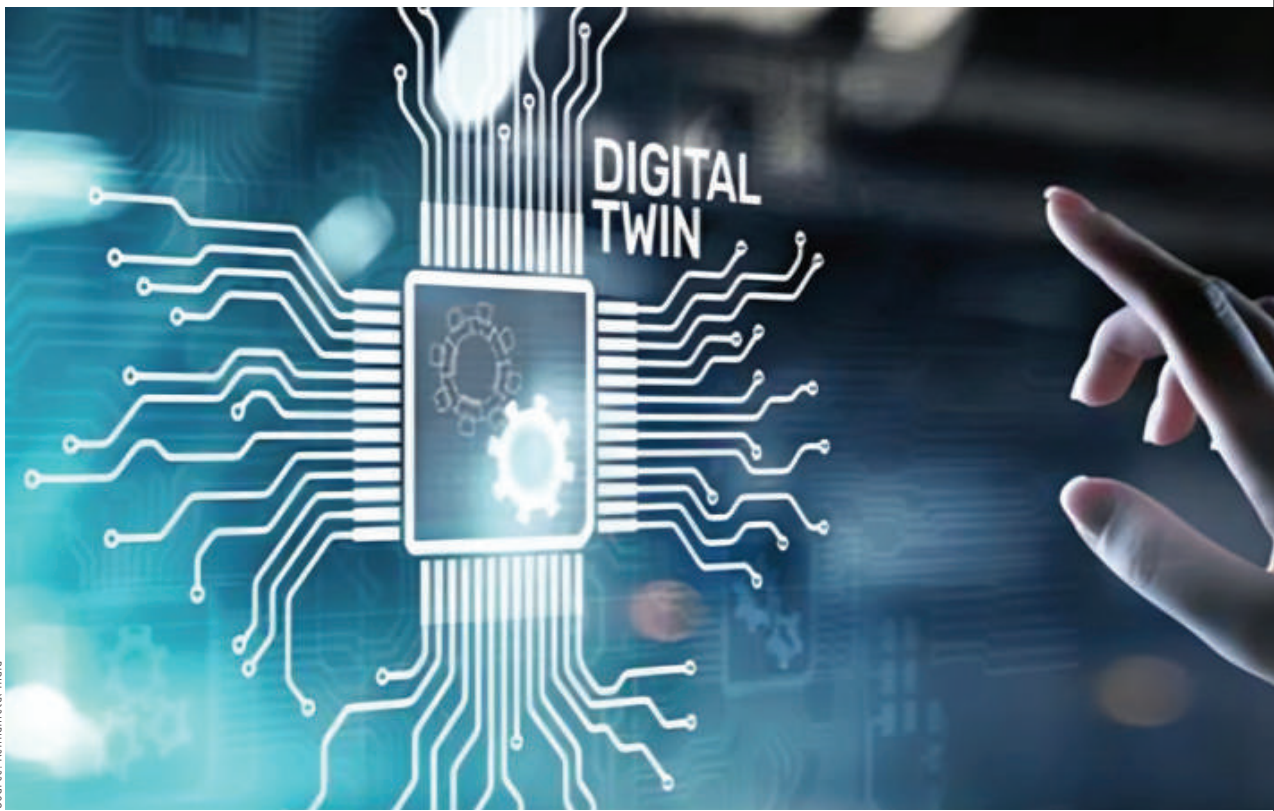

Source: Kennametal India

**W**e live in a fast-paced world where new technologies are adopted faster than ever before. In manufacturing, specifically in in-part production, we are observing a transformation due to the ever-increasing use of cloud-enabled, connected data platforms that aid high-volume transactions, interactions, and relationships from hundreds of data sources. These platforms also unify data from multiple standalone sources and present a

comprehensive view to support real-time decision-making, more commonly referred to as Data-Driven Decisions (DDD).

Also evolving are customers' machining requirements. Customer requirements can range from machining a complex 5-axis part with a high machinability index and tight tolerances to prioritizing the optimization of machining strategies to streamline processes, drive productivity, control cost, and reduce waste.

## Understanding digital twin

In order to help customers solve machining challenges, Kennametal utilizes an innovative end-to-end solution-driven approach called 'Digital Twin'. Digital Twin is a blueprint for smart machining. A 'digital twin' is a virtual model that is designed to represent a physical object or product accurately and precisely in this case. It can be tested and validated before it is put into production and the market.

KARTHIK RAMAN  
Head  
Product Management –  
India & Middle East  
Kennametal India Ltd



Source: Kennametal India



chining operation in a virtual setting with the right process parameters so that issues or adjustments can be addressed in the planning stages as opposed to later, potentially halting operations. Digital twin replicas also help translate machining results to performance by allowing for a precise estimation of chipping loss, cycle time, and exe-

cutable NC codes. The bottom line is that better decisions are made on the shop floor. With Kennametal and its blueprint for smart machining, customers can create custom tool path simulations and ac-

A digital twin allows engineers and process planners to identify any process failures before the part goes into actual production.

Complex multi-axis machines require a deep knowledge and understanding of fixtures, cutting tools and processes, as well as programming.

Kennametal's digital twin solution helps customers visualize the complete ma-

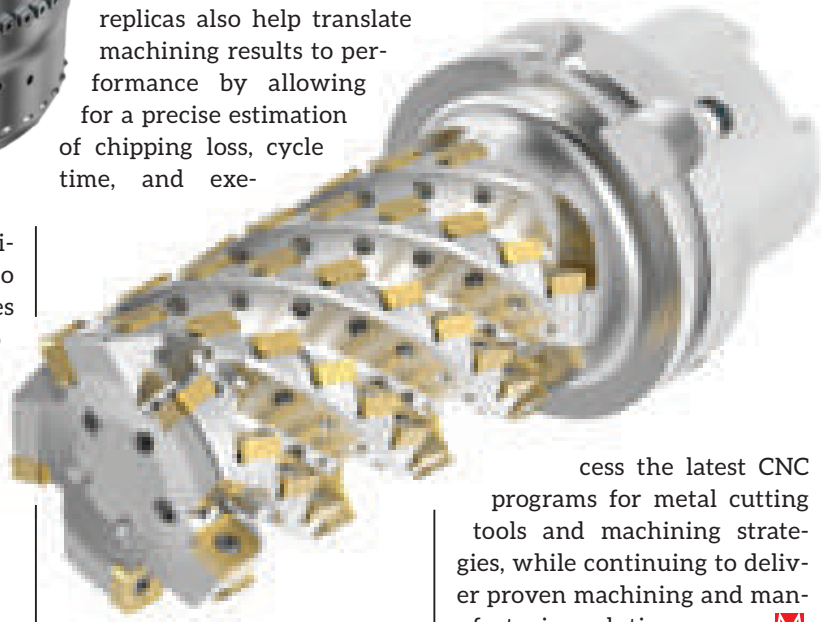

cess the latest CNC programs for metal cutting tools and machining strategies, while continuing to deliver proven machining and manufacturing solutions. 

With Kennametal and its blueprint for smart machining, customers can create custom tool path simulations and access the latest CNC programs for metal cutting tools and machining strategies, while continuing to deliver proven machining and manufacturing solutions.



**MODERN  
MANUFACTURING  
INDIA**

WWW.MMINDIA.CO.IN

The Official Magazine of



Indian Machine Tool  
Manufacturers' Association

In Association with



# When Goals Matter!



For Advertising Contact: MURALI SUNDARAM | E: murali.sundaram@magicwandmedia.in | M: +91 9740048390

## WITH THE CUSTOMER IN MIND

For Milacron India Pvt Ltd (MIPL), a leading higher-tonnage injection molding machines manufacturing company, a strategic approach helped overcome challenges in its endeavor to offer high-performing and cost-competitive products tailored to meet customer needs.

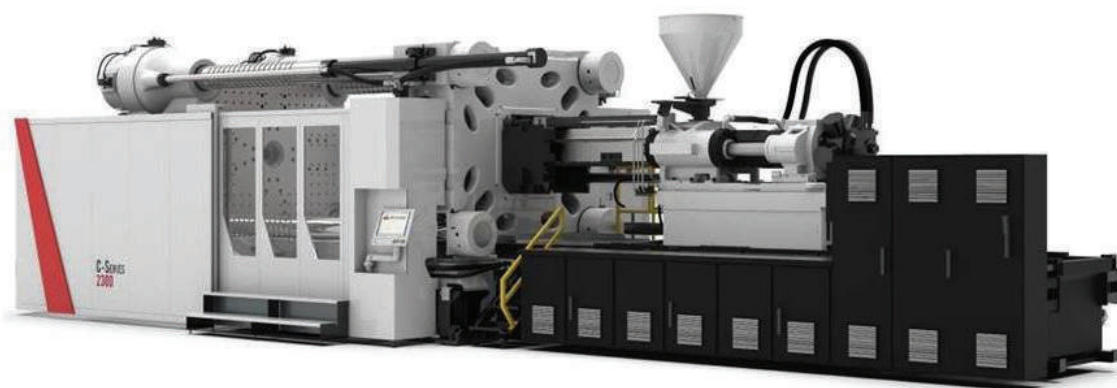

Source: Milacron India Pvt Ltd

The final product

**H**igher-tonnage injection molding machines are a promising product offering from Milacron India Pvt Ltd (MIPL). However, the company faced challenges from competitors in the market, and in order to become a market leader as an original equipment manufacturer (OEM) for higher-tonnage injection molding machines, it was essential to provide high-performing products at competitive costs while maintaining the best quality. A strategic approach was thus required to overcome the challenges encountered. Thus, MIPL implemented a systematic plan to meet customer requirements and address these challenges effectively.

In our endeavor to close the gap between our customers and ourselves, we initiated a comprehensive customer survey. Through this survey of higher-tonnage machines, we gained valuable insights that highlighted the significant area of improvement with in the clamp unit of our plastic

processing machines. This feedback from our customers provided us with a clear direction.

As a prominent manufacturer of tailor-made plastic processing machines, it is crucial for us to adapt to the changing market conditions and meet the evolving demands of our customers. We recognize the importance of delivering machines on time and ensuring performance. To achieve this, we had to curb the cost and gain an edge over our competitors.

### **Solution generation, innovation, and complexity**

The customer survey provided us with valuable insights and feedback, allowing us to focus on the clamp unit to align with them.

- **Material Selection:** We evaluated the materials for conceptual weight reductions that led to improvement in closing speed, resulting in cost reduction without compromising functionality and performance. We also looked for alternative materials that

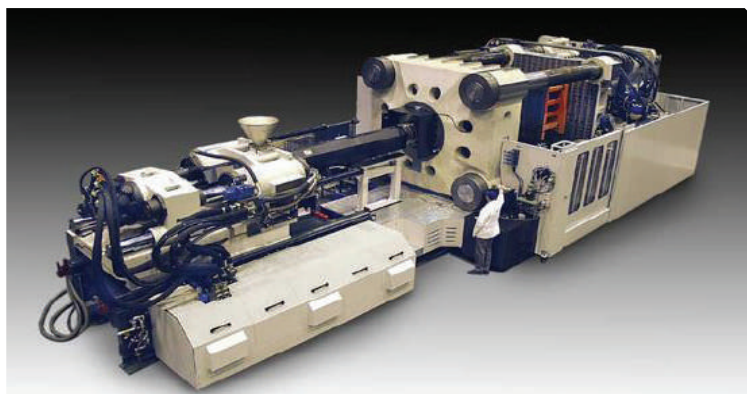

Source: Milacron India Pvt Ltd

DEVESH DUDHWALA  
Deputy General  
Manager — Design  
Milacron India Pvt Ltd



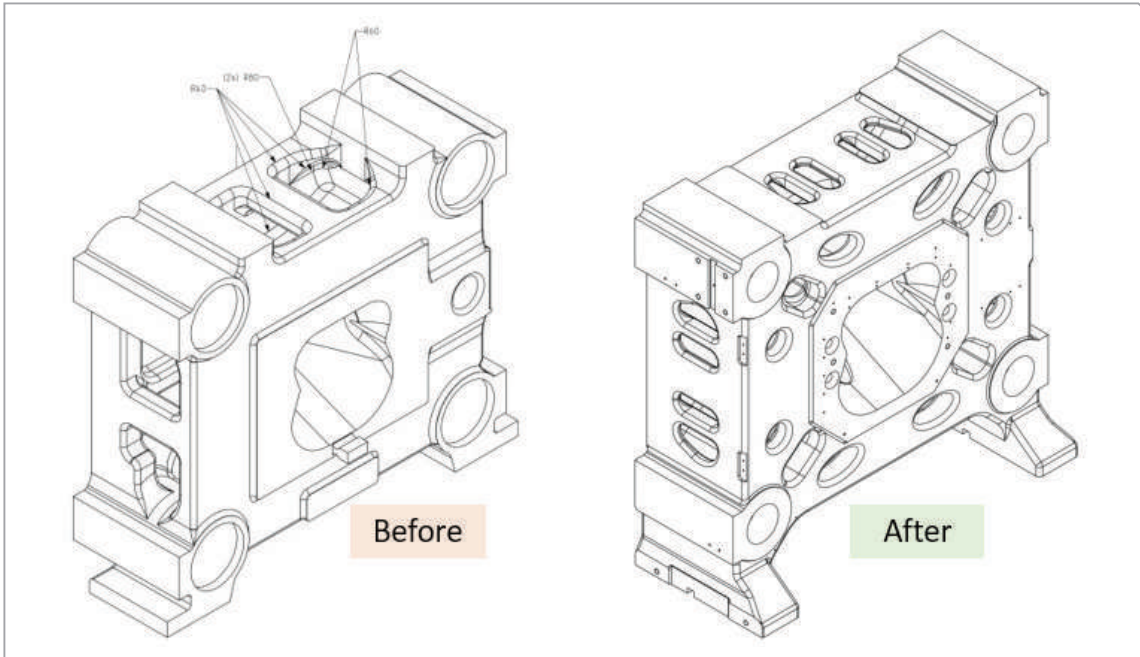

could provide similar or better properties at a lower cost.

- **Design for Manufacturability (DFM):** We optimized the clamp unit design for efficient manufacturing processes and considered factors such as ease of machining, reduced scrap or waste, and ways to minimize the need for specialized tooling or processes. This helped lower production costs.
- **Value Engineering:** A value engineering analysis of the

clamp unit was conducted to identify areas where cost savings could be achieved. This involved evaluating the function of each component and exploring alternative designs or manufacturing methods to reduce costs while maintaining performance.

- **Supplier Collaboration:** We thought it was crucial to engage with suppliers and manufacturing partners to explore cost-reduction opportunities. We sought their

input and expertise in identifying alternative materials, design modifications, or process improvements.

- **Design Failure Mode and Effects Analysis (DFMEA):** Through DFMEA, we proactively identified and mitigated potential failure in the design stage, ensuring high product quality and customer satisfaction.
- **Continuous Improvement:** A system was established for

During validation, we covered all real-world operating conditions and the anticipated loads and constraints in the defined application. The results were found satisfactory in all segments.

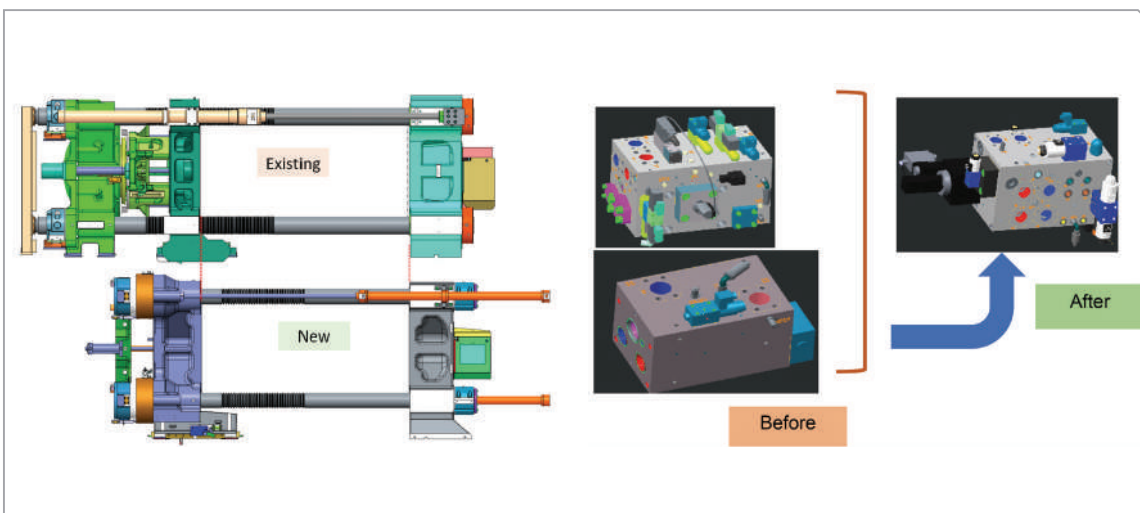

ongoing cost optimization and continuous improvement. The production data was regularly monitored and analyzed. Feedback from customers and suppliers were regularly sought and industry trends explored to identify further opportunities for cost reduction in the clamp unit.

To reduce the weight of the clamp unit casting, we initially introduced a compact design. However, the weight reduction achieved was only an average of 10 percent in the first design, falling short of our target. In response, we conducted brainstorming sessions again and performed Finite Element Analysis (FEA) at an optimum level to identify further opportunities for cost reduction. The outcome exceeded our expectations with an impressive reduction of an average of 22 percent without compromising the machine's performance and specifications. Based on customer and market requirements, we developed best-in-class clamp force and

The outcome exceeded MIPL's expectations with an impressive reduction of an average of 22% without compromising the machine's performance and specifications.

**Result:**

Cost reduction per machine	~ 10 %
Increase in the number of higher-tonnage machines	~ 90 %
Contribution of higher-tonnage machines to revenue	~ 10 %
Increase in revenue generation per manpower	~ 35 %
Increase in the market share of higher-tonnage machines	2.2 times

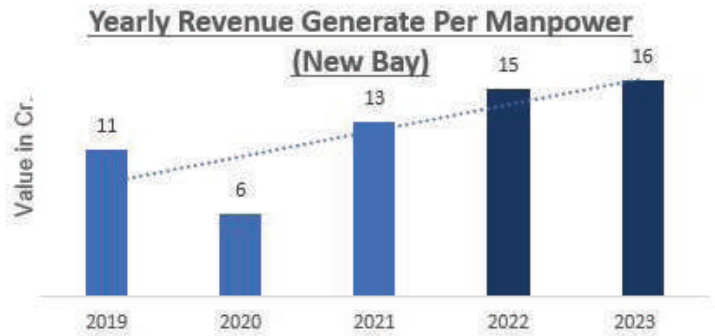

Tie bar spacing against our competitors as per the below table. After successfully achieving all our targets and thoroughly evaluating the design with FEA analysis, we moved on to our next crucial step: manufacturing the clamp unit based on our finalized design, installing it

at our on-site location for a specific time, and validating it as per standards and customer requirements. During validation, we covered all real-world operating conditions and the anticipated loads and constraints in the defined application. The results were found satisfactory in all segments.

**Sustainability Results:**

M/c assembly weight reduction in tonne	~ 24 %
Power consumption reduction in kwh/kg	~ 15 %
Grease consumption reduction per week	~ 30 %
Floor space reduction in meter	~ 20 %

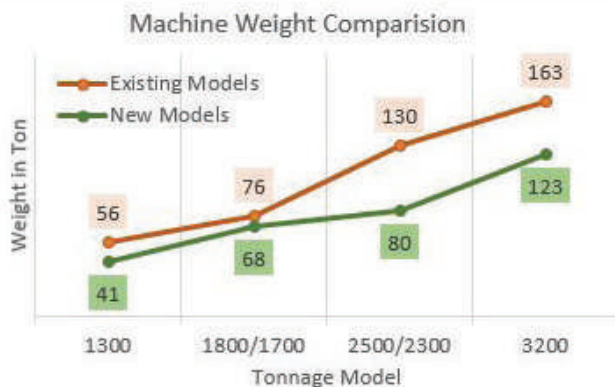

We faced several challenges during the implementation of this project:

- Achieving cost reduction with the same tonnage specifications and machine performance;
- Ensuring expertise in casting manufacturing and supplier competency;
- Establishing proficiency in the plating process on castings at the supplier's end;
- Ensuring the quality performance of clamp castings is enhanced;
- Developing suppliers for casting machining of large-sized components;
- Single-piece machine loading through the existing crane facilities.



Indian Machine Tool  
Manufacturers' Association

# FACTEQ 2024

## Factory Equipment Expo

23 - 26 May 2024, Pune International  
Exhibition and Convention Center, Pune

Powered by IMTMA, organizer of **IMTEX**

Co-located with **PUNE MACHINE TOOL EXPO 2024**

# A FIRST OF ITS KIND IN INDIA



## **FACTORIES OF TOMORROW BUILD • MAINTAIN • UPGRADE**

Safe, Sustainable & Environment Friendly Solutions

For stall bookings

Visit: [www.facteq.in](http://www.facteq.in)

Contact

Hannah Victoria

M: 9731040077 | E: [hannah@imtma.in](mailto:hannah@imtma.in)

## WELDING ON EV BATTERY AND AUTOMATION

In today's growing trend of electric vehicles, demand for battery tray welding solutions is increasing. With this, industries are seeking new and more efficient methods.

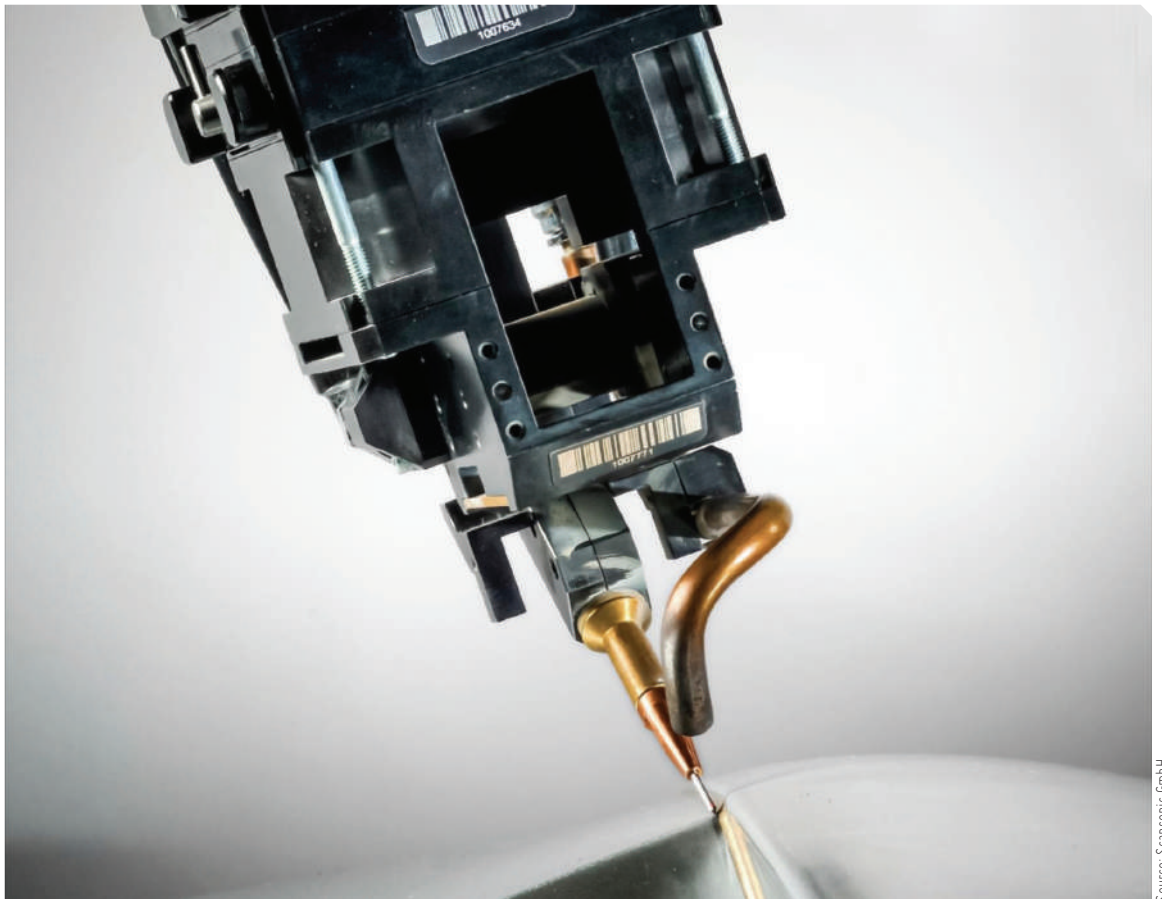

Image 1: Tactile Welding

Source: Scansonic GmbH

**G**enerally, for Battery Tray Welding applications, strength is necessary for resisting various impacts and at the same time, the weight of the vehicle must be as low as possible. The Aluminum Al 5XXX/Al 6XXX series is suitable for this application because it is a light material and also has high strength. However, welding Aluminum has its own problems like hot cracking, porosity, and gaps, specifically for larger parts like battery trays, etc. that can be mitigated using advanced joining methods.

### Laser Welding: an advanced method

A laser beam is focused on the seam profile, which melts the edges and then after solidifying, the edges are fused. There are 2 methods for Laser Welding:

**Tactile Welding:** This method uses a filler wire which also acts as a tactile sensor. The wire is constantly under control and in touch with the seam, which acts as a sensor and senses the seam profile. Welding is done accordingly. The filler wire can also be used to bridge the gaps. With the optional oscillation feature, even larger gaps can be bridged.

For Al 6XXX, using filler wire is the only option for avoiding hot cracks. The fixture shows ALO4, the optics that Scansonic has developed for Tactile Welding (Image 1).

**Remote Welding:** In this method, there is no filler wire, it is mainly suitable for lower-strength Aluminum grades like Al 5XXX. The small beam spot providing high power density is controlled using a fast-moving mirror mechanism. Seam tracking is done using the optical triangulation method, which even detects vertical gaps. For vertical gap bridging, the adaptive beam oscillates accordingly along the upper and

MICHAEL NAGEL  
Global Key  
accounts Manager  
Scansonic GmbH



Source: Scansonic GmbH

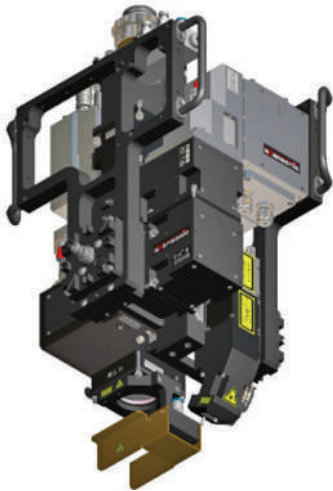

Image 2: Remote Welding

lower edges. Materials from the upper edge are melted and the molten weld pool is directed towards a lower edge to bridge the gap. One of the greatest advantages of this method is that it can be done very fast and at a higher working distance. Image 2 shows the Scansonic Remote Welding Optics: RLW - A.

### SCeye: Process Monitoring

Currently, how industries are operating is evolving drastically. Industries are seeking new methods to have more control over their processes to achieve more accuracy, minimize errors, reduce lead time, and make the processes more efficient.

The advanced SCeye module is a process monitoring system. As the name suggests, it monitors

Source: Scansonic GmbH

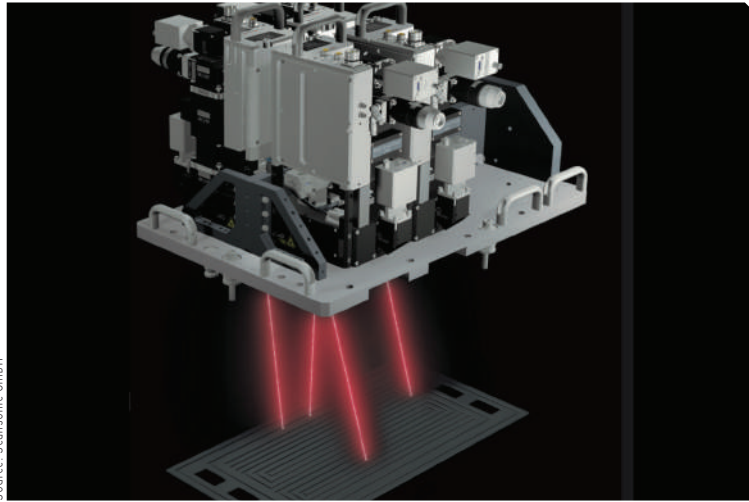

Image 4: Compact Scanner Unit

the welding process and records different process and machine parameters like laser power, robot speed, wire feed rate, pressure, Z position, etc. Up to 16 such process parameters can be recorded and analyzed.

### Advantages of SCeye

Oil residues, pores, and other such defects can be easily detected by visual inspection. Combined with an AI algorithm and trained program, it may even eliminate the need for a separate inspection station. As all the process parameters and even visuals for each part are recorded, if there are any defects in a particular part, it is possible to check the process parameters for that particular part, and detection of the root cause for the defect becomes easier.

### Parallelization of processes by using compact scanner units (CSC)

Fast component welding (FCW) is the recent contribution by Scansonic to accelerate production processes e.g. for high welding speed demands on long weld seams, where physical limits stop further increase of laser power or laser beam brilliance.

The very compact scanner unit allows the assembly of a number of CSC units with the lowest footprint on an individual applications rack. Instead of running one remote unit along the component, multiple CSC units working parallel on individual segments of the part. This reduces the cycle time by the amount of units utilized, for instance 50 percent less cycle time with 2 CSC units versus 1 remote scanner head.

Besides state-of-the-art scan fields, further provisions are for instance three different camera ports at different positions in the beam path, which enables easy teaching processes and can be used for process control and image recognition. By new creative approaches many more laser applications are now possible respecting today's efficiency demands in serial production e.g. for welding of battery cooling plates, fuel cells, or even hairpins. 

Scansonic has recently found a way to harness AI in process monitoring. The new AI, when integrated with the SCeye system, analyzes the raw data with the help of deep learning. Once the system is trained to detect specific errors, it automatically detects the defects and even eliminates the need for visual inspection.

Source: Scansonic GmbH

### SCeye Process Visualization and AI

Machine learning to ensure quality requirements

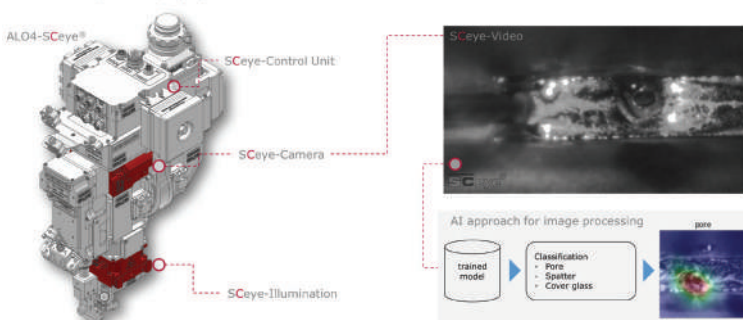

Image 3

# RECYCLING FOR A BETTER TOMORROW

Ensuring environmental sustainability calls for sustainable recycling practices. In this project, researchers from SASTRA University have found a unique way to repurpose D2 steel chips, often discarded after machining, to create useful trimming dies.

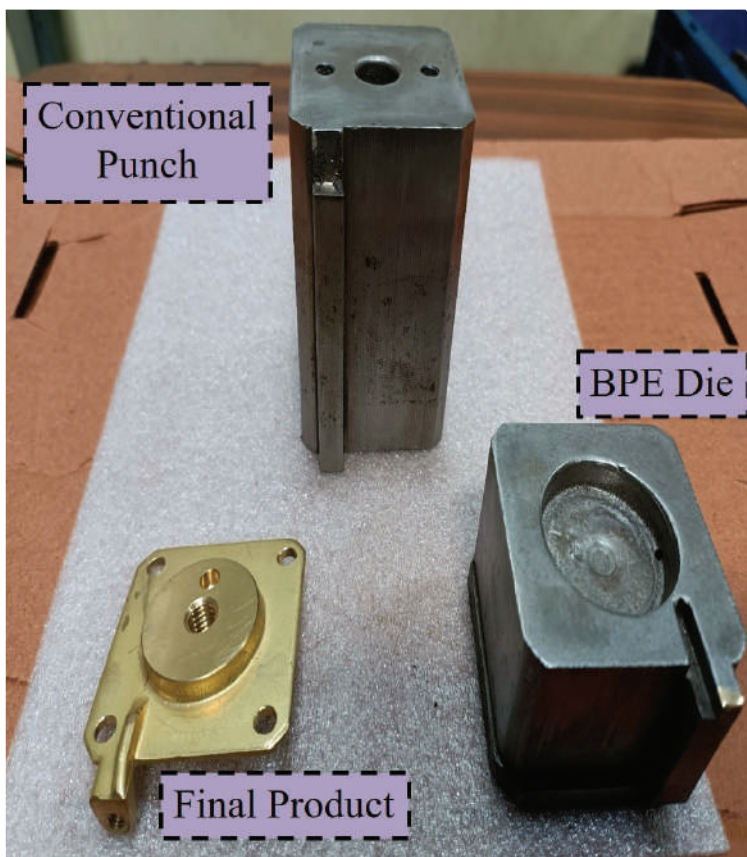

Figure 3 Manufactured component

DR RAJ MOHAN R  
Faculty  
Bajaj Engineering Skills  
Training (BEST) Centre  
SASTRA Deemed to be  
University  
rajmohan.best@  
sastra.ac.in



S RAKESH  
Research Scholar  
School of Mechanical  
Engineering  
SASTRA Deemed to be  
University  
rakeshsivakumar04@  
gmail.com



**I**n industries, it's crucial to manage D2 tool steel chips obtained from conventional machining centers. D2 cold-worked steel, also referred to as AISI D2 or DIN 1.2379, is widely used in various industrial applications like tool and die making, cold work tooling, metalworking tools, cutting and slitting blades, machine components, etc.

This steel offers a great combination of properties, including high wear resistance, good toughness, and relatively good machinability compared to other tool steels. Compared to other tool steels, D2 steel demonstrates moderate to good machinability. However, dealing with D2 steel can also be quite challenging because of its high hardness and abrasion resistance. It may

necessitate specific tooling, cutting speeds, feeds, and the use of coolant/lubricant to ensure successful outcomes.

## Different recycling techniques for D2 chips

After the machining process, D2 chips are created that can be recycled by crushing and melting. However, the melting process faces several limitations and demands increased energy usage. Recycling metal through these methods requires over 6,000 lt of water per metric tonne of production. When D2 steel chips are remelted, they are heated to high temperatures, leading to the release of particulate matter and metal fumes into the air. The emissions may include dangerous substances like chromium, manganese, and other alloying elements found in D2 steel. These issues lead to a permanent metal loss of 15 percent to 25 percent.

Recent research has explored different techniques for recycling copper chips, including Electro-winning and Ball-milling (BM) methods. Additionally, the ball-milled fine particles serve as the primary material for the additive manufacturing (AM) process. During the process, recycled copper powders are used for tool electrodes in electro-discharge machining (EDM) to achieve high relative density.

In addition, different techniques in the field, like fused filament fabrication (FFF), electron beam melting, selective heat sintering, selective laser melting, and selective laser sintering, utilize D2 steel for different purposes. When comparing methods, FFF is seen as a practical extrusion technique for creating detailed copper parts.

The FFF is integrated with the binder jet process, known as bound powder extrusion (BPE). When using the BPE technique, the base powder is combined with waxy polymers like those used in metal injection molding to manage powder loss.

**Bound Powder Extrusion**

Previous research on D2 tool steel

in additive manufacturing has not emphasized the sustainable practice of recycling D2 chips to create the trimming die used in the post-forging trimming process. Hence, the main goal of the project is to create a recycled D2 swarf trimming die using the BPE process and assess how well the component performs in the flash trimming process. At first, a two-step BM was conducted on a copper chip, taking advantage of the smaller size of the copper chips in the BPE process. Following that, the BPE process parameters underwent optimization through the Box-Behnken design (BBD). Next, the D2 samples were created under ideal conditions to analyze the microstructure and mechanical properties and then compared to traditional D2 steel, which showed positive results. After analyzing the results, the D2 trimming die was produced using the BPE method and implemented in the flash trimming process at Shanmugha Precision Forging located in Thanjavur, Tamil Nadu. By producing trimming die from recycled D2 steel machined chips, the overall manufacturing cost for the die has decreased by 15 percent, and the lead time has been reduced by 68.18 percent.

By producing trimming die from recycled D2 steel machined chips, the overall manufacturing cost for the die has decreased by 15%, and the lead time has been reduced by 68.18%.

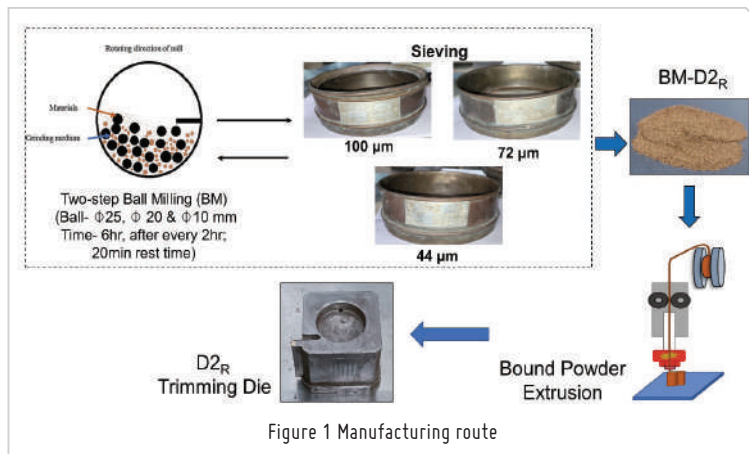

Figure 1 Manufacturing route

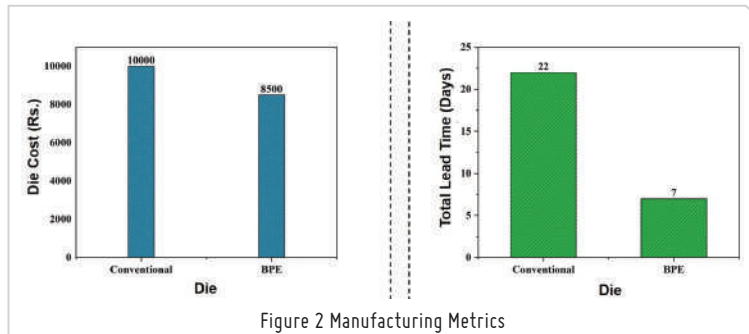

Figure 2 Manufacturing Metrics



MODERN  
MANUFACTURING  
INDIA  
[www.mmindia.co.in](http://www.mmindia.co.in)

The Official Magazine of



Indian Machine Tool  
Manufacturers' Association

In Association with





**WHERE YOU ARE IS AS  
I M P O R T A N T  
AS WHO YOU ARE**

For Advertisement reach out to  
**MURALI SUNDARAM**  
E: [murali.sundaram@magicwandmedia.in](mailto:murali.sundaram@magicwandmedia.in) | M: +91 9740048390

# IMTEX FORMING 2024: A SHOWCASE OF INDIA'S MANUFACTURING PROWESS

IMTEX FORMING 2024 presented itself as a comprehensive display of the advancements in metal forming and manufacturing technologies. While the groundbreaking indigenous innovations served as a confirmation that we are nearing the goal of becoming a coveted manufacturing hub, the enthusiastic international participation proved us as a market with immense potential.



L-R: Rajendra S Rajamane, President, IMTMA; CK Venkataraman, Managing Director, Titan Company Ltd; Mohini Kelkar, Vice-President, IMTMA; Geetanjali Kirloskar, Chairperson & Managing Director, Kirloskar Systems Pvt Ltd; Jamshyd N Godrej, Chairman- Exhibitions – IMTMA and Jibak Dasgupta, Director General & CEO, IMTMA and BIEC at the opening ceremony.

**I**MTEX FORMING 2024 & Tooltech 2024 stand as a crucial platform to showcase our strengths in manufacturing for the Indian Machine Tools sector to grow and contribute to our holistic progress. Asia's largest exhibition on metal forming technologies, organized by Indian Machine Tools Manufacturers' Association (IMTMA), held from January 19-23, 2024, at Bangalore

International Exhibition Centre (BIEC), concluded successfully. The exhibition featured over 625 exhibitors from 20 countries in an exhibition space of around 45,000 sq mt, covering 5 exhibition halls. Around 1,000 trade delegation members and 40,000 visitors attended IMTEX FORMING 2024. The exhibition portfolio has enlarged with the entry of Wel-dexpo, an exhibition for weld-

ing, cutting, and joining in association with the Indian Institute of Welding (IIW) as a concurrent show alongside Tooltech and Digital Manufacturing. The event concluded with 80 percent growth in size and business orders worth ₹550 Cr and enquiries of ₹5,000 Cr.

### Opening ceremony

Set against the backdrop of state-of-the-art machinery and

POONAM PEDNEKAR  
Chief Copy Editor  
Magic Wand Media Inc  
poonam.pednekar@  
magicwandmedia.in





“If India develops, it has to develop more as an integrated country. The job of the industry to spread out more and more is very important. I hope that exhibitions such as IMTEX FORMING allow us to promote interconnectedness and a developed India.”

**JAMSHYD N GODREJ**  
Chairman  
Exhibitions - IMTMA

visionary insights, the inaugural ceremony of IMTEX FORMING 2024 & Tooltech 2024 instilled a sense of optimism as industry experts supported their insightful deliberations on the trends and technologies within the metal forming sector with awe-inspiring numbers, echoing the industry's unwavering commitment to progress.

The eighth edition of IMTMA's flagship event and Asia's largest exhibition on metal forming and manufacturing technologies, IMTEX FORMING & Tooltech, was inaugurated with the traditional lamp lighting ceremony by the Guest of Honor CK Venkataraman, Managing Director, Titan Company Ltd and Chief Guest Geetanjali Kirloskar, Chairperson & Managing Director, Kirloskar Systems Pvt Ltd. Other dignitaries present included Jamshyd N Godrej, Chairman, Exhibitions - IMTMA; Rajendra S Rajamane, President, IMTMA; Mohini Kelkar, Vice President,



“The Automotive sector and the Machine Tool industry have a symbiotic relationship with one sector's growth pushing the demand in the other. The growth of the automotive sector has been the driving force for machine tools for many years.”

**GEETANJALI KIRLOSKAR**  
Chairperson &  
Managing Director  
Kirloskar Systems Ltd

IMTMA; and Jibak Dasgupta, DG & CEO, IMTMA.

Rajamane emphasized the need for the Machine Tool industry to diversify beyond serving traditional sectors like automobiles. “The focus should be on producing highquality, reliable products that can compete globally and encouraging innovation to gain a competitive edge. The

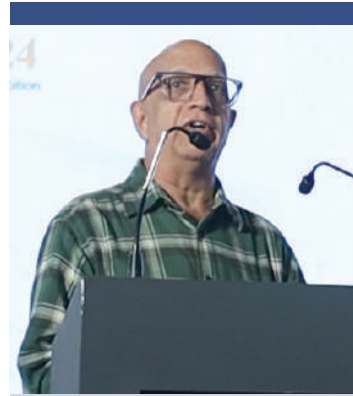

“The Indian Machine Tool industry caters to the Automotive sector in a big way today. However, it has to focus on precision manufacturing too, so that we can reliably depend on our domestic machine tools manufacturers completely.”

**CK VENKATARAMAN**  
Managing Director  
Titan Company Ltd

industry is urged to develop energy-efficient, multitasking machines with an eye on exporting to global markets,” he added.

**Making the right connect** CONNECT, the vibrant gathering for mechanical and electrical engineering students, offered a platform for students to engage with more than 15

**Snapshot**

Exhibitors:  
625+

Visitors:  
44,779

Countries: 20

Enquiries:  
₹4,500 - 5,000  
Cr (US\$ 590 M)

Orders:  
₹500 - 550 Cr  
(US\$ 60 M)



Indradev Babu, Managing Director, UCAM Pvt Ltd (fourth from right) was awarded IMTMA DB Cooper Award for outstanding supply chain unit in memory of Sir D. B. Cooper to recognize units in the supply chain of the machine tool industry.

In addition to record-breaking attendance, IMTEX FORMING 2024 & Tooltech 2024 also marked the presence of 1,000 trade delegation members. The event's expansion included the addition of Weldexpo, culminating in significant business orders and inquiries.



“The quality of the visitors was notable, and it was satisfying to connect with our existing customers and new potential buyers. Although it’s customary to measure the business results from trade events after 6 months, we have already closed orders worth INR 500 million.”

**NIRAJ SETH**  
President  
AMADA India Pvt Ltd

distinguished companies from Bengaluru, Chennai, Mumbai, Pune, and Hyderabad. Industries showcased their company profiles, technology, and job requirements, fostering connections between students and potential employers.

At the opening ceremony, Jibak Dasgupta, DG & CEO, IMTMA, clarified the distinctive aspect of CONNECT in comparison to other job fairs. He explained that candidates gain real-time exposure to the nature and work environment of the positions they aspire to. CONNECT enabled Diploma and BE/BTech graduates with 0-2 years of experience to demonstrate their skills and competitiveness, equipping them for the dynamic Manufacturing industry.

**Beefing up industry-academia bond**

Organized by Indian Machine Tool Manufacturers’ Associa-



“The tune of business generated at IMTEX FORMING 2024 is expected to be extraordinary. Our range of high specialty copper alloys, marketed under the brand name of AMPCO® and AMP-COLOY®, received significant attention, and our quality products and services helped us generate promising business leads.”

**TUSHAR PAWAR**  
National Head  
AMPCO METAL India Pvt Ltd

tion, the manufacturing technology quiz was focused on emerging technologies. The quiz was woven around the theme of the future of manufacturing. Participants from several engineering colleges took part in the competition. M. S. Ramaiah University of Applied Sciences, Bangalore, bagged the first position and a cash prize of ₹10,000 and Chennai Institute of Technology, second position and a cash prize of ₹5,000 respectively.

In a momentous celebration at IMTEX FORMING 2024, the i2 Academia Square witnessed the acknowledgment of outstanding students, marking an inspiring chapter in IMTMA’s commitment to nurturing future talent. The winning colleges included: SASTRA Deemed University, Thanjavur (First Prize); KLS Gogte Institute of Technology, Belagavi, Karnataka (Sec-



“There was a notable increase in the quality and seriousness of the visitors as compared to the previous editions of IMTEX FORMING. We could also observe a shift in the approach to CAPEX and OPEX requirements among attendees.”

**TV MOHAN**  
Country Head & MD - India  
**ANDREAS MAIER**  
Workholding Technology  
Pvt Ltd

ond Prize); Chennai Institute of Technology, Chennai (Third Prize); Amrita Vishwa Vidyapeetham, Amritapuri (Consolation Prize First); and Indian Institute of Technology, Bombay (Consolation Prize Second).

The i2 Academia Square is a flagship initiative of IMTMA to promote collaboration between industries and academia, develop transformative new technologies, and understand each other’s contexts and challenges.

**Jagruti, raising awareness is key**

The Jagruti - IMTMA Youth Program, held during IMTEX, is to familiarize the engineering students with the machine tool industry and the technological developments in the industry segment. The two-day program during IMTEX FORMING 2024 attracted 26 engineering college students from different parts of India.



“The business prospects generated at IMTEX FORMING 2024 have been remarkable, with over 800 leads, indicating strong future partnerships and sales potential. Our team at LTPL is thrilled with the outcomes of our participation and the opportunities it has unlocked for the future.”

**PANKTI AGARWAL**  
Director  
Laser Technologies Pvt Ltd

### Rewards and recognition

In a grand ceremony at the event, IMTMA announced two prestigious awards: IMTMA Export Performance Award and IMTMA Best Design Award. These awards, instituted in 2023, honor member companies that have excelled in machine tool exports and demonstrated excellent indigenously designed products. While ISGEC Heavy Engineering Ltd received the award in the Metal Forming Manufacturer Category, Jyoti CNC Automation Ltd bagged the award in the Metal Cutting Manufacturer Category. Electropneumatics & Hydraulics (I) Pvt Ltd was presented with the award for the CNC hybrid bender model 50CNC5X3. INDSPHINX Precision Ltd received the award in the Sub-System/Accessories Manufacturer Category. ITL Industries Ltd received the Jury Appreciation Award. Valgro India Ltd received the award for the Deburring edge

rounding and scale removal machine: SLR2BD.

### Encouraging self-reliance in India's forming technology

Held a day prior to the show, the International Seminar on Forming Technology (ISFT) 2024 laid the foundation for a comprehensive exploration of forming technology innovations and applications. The sessions highlighted the Metal Forming industry's challenges and potential, particularly in light of the indigenization of India's defence.

### Exhibitors' POV

Reflecting on the success of IMTEX FORMING 2024, Niraj Seth, President, AMADA India Pvt Ltd, noted that there was a considerable increase in the visitors' footfall as compared to the previous edition.

This time the company, under the theme 'Future Technologies with AMADA', exhibited several innovations for the Indian sheet metal market. “Our machinery, offering higher productivity but also conforming to sustainability standards, drew considerable attention from customers. Notably, VENTIS with LBC technology and Bending with automation were the highlights of our display.”

Seth pointed out that although it's customary to measure the business results from trade events after 6 months, they have already closed orders worth ₹500 million.

Talking about his experience at the show, Siddhu Jolad, Managing Director, RadCAM Technologies Pvt Ltd, shared that they received a substantial number of visitors in the event's five days. “We met around 1,000 prospects/customers comprising about 15 percent of potential customers and around 20 percent of existing customers. This promises a good amount of conversion,” he stressed.



“We are satisfied with the level of interest and engagement received at IMTEX FORMING 2024. We received a significant number of inquiries and positive feedback for the bevel machine ELEMENT 400 featuring an IPG 20kW laser power source, along with the FiberLight 3kW laser machine equipped with a compact material handling solution.”

**MANI NARAYANAN**  
Managing Director  
Messer Cutting Systems India Pvt Ltd

Tushar Pawar, National Head, AMPCO METAL India Pvt Ltd, remarked, “IMTEX FORMING 2024 attracted a diverse range of professionals from various sectors, all eager to explore the latest innovations and solutions in the manufacturing sector. The sheer magnitude of the visitor footfall at IMTEX 2024 spoke volumes about the exhibition's impact and relevance within the industry.”

“Our primary expertise lies in the production of wiper dies and mandrels, which garnered substantial interest and interaction from visitors during the exhibition,” he explained.

For Pankti Agarwal, Director, Laser Technologies Pvt Ltd (LTPL), IMTEX FORMING 2024 was a phenomenal success in terms of visitor engagement and interest. “We are proud to report a substantial footfall at our state-of-the-art booth, which was nota-

The opening ceremony of IMTEX FORMING 2024 & Tooltech 2024 highlighted industry optimism and commitment to progress, with insightful deliberations and visionary insights setting the tone for the event.

**IMTEX FORMING 2024 & Tooltech 2024** witnessed remarkable success stories and industry recognition, with companies reporting substantial inquiries, orders, and partnerships, reflecting the event's impact on the manufacturing sector.



“Although all our machines garnered attention, our popular Euromac turret punching machine, the latest XT model stood out. Our EUROMAC Digibend 400 CNC was a clear winner too. We currently have more than 50 promising inquiries and we look forward to generating around ₹30 crore of business.”

**SIDDHU JOLAD**  
Managing Director  
RadCAM Technologies Pvt Ltd

bly the largest at the event. The influx of visitors translated into a satisfying conversion rate, striking a healthy balance between potential and existing customers. Our commitment to innovation and quality was met with an enthusiastic response,” she noted. “The business prospects generated at IMTEX FORMING 2024 have been remarkable, with over 800 leads, indicating strong future partnerships and sales potential. Our team at LTPL is thrilled with the outcomes of our participation and the opportunities it has unlocked for the future,” she added.

**Success stories galore**

IMTEX FORMING 2024 was a significant success for SLTL Group too. The company witnessed a substantial increase in visitor footfall compared to previous years. Sharing the experience at the event, Maulik Patel,



“IMTEX FORMING 2024 served as one of the best platforms to showcase our innovative products and technologies to a diverse audience, resulting in effective interactions and genuine business opportunities. It proved to be crucial in growing our market presence and propelling SLTL forward.”

**MAULIK PATEL**  
Executive Director  
Sahajanand Laser Technology Ltd

Executive Director, Sahajanand Laser Technology Ltd, said that the Ultra-high power 2D laser cutting machine - Infinity F1 and the tube cutting machine - T6200, both launched with intelligent features and automation, garnered significant attention and were quickly adopted by their clients due to the machines advanced features, precision, and efficiency.

Patel expressed satisfaction with the remarkable surge in activity. “IMTEX FORMING 2024 resulted in a notable increase in inquiries, orders, and partnerships for SLTL,” he noted. “The tune of business produced at the event showed a notable increase, indicating strong growth and consumer trust in our innovative solutions. This event served as one of the best platforms to showcase our innovative products and technologies to a diverse audience, resulting in ef-

fective interactions and genuine business opportunities. It proved to be crucial in growing our market presence and propelling SLTL forward, both in terms of gaining new clients and fortifying ties with current ones.”

Mani Narayanan, Managing Director, Messer Cutting Systems India Pvt Ltd, expressed satisfaction with the level of interest and engagement received at IMTEX FORMING 2024. He shared, “As the sole provider of thermal plate cutting solutions, including Oxyfuel, Plasma, and Laser technologies, we showcased our cutting-edge offerings, notably the ELEMENT 400 laser machine with an IPG 20kW laser power source and the FiberLight 3kW laser machine equipped with an Automated Plate Handling Solution for thermal cutting.”

The company received a significant number of inquiries for the bevel machine ELEMENT 400, featuring an IPG 20kW laser power source, along with the FiberLight 3kW laser machine equipped with a compact material handling solution. “We received positive feedback for both of these machines, reflecting their performance. Additionally, our Oxyfuel equipment was prominently featured at the entrance. We have received a substantial volume of feedback regarding ELEMENT 400.”

TV Mohan, Country Head & MD - India, ANDREAS MAIER Workholding Technology Pvt Ltd, noted an increase in the quality and seriousness of the visitors as compared to the previous editions of the event. He also observed a shift in the approach to CAPEX and OPEX requirements among attendees.

The company had around 20 to 25 customers per day enquiring about its Guethle product programs and solutions for better shop productivity. 



International Machine Tool &  
Manufacturing Technology Exhibition

Concurrent shows



International Exhibition of Cutting Tools, Tooling Systems,  
Machine Tool Accessories, Metrology & CAD / CAM



International Exhibition on  
Digital Manufacturing Technology



# Largest Machine Tool and Manufacturing Technology Show in South and South-East Asia

23 - 29 January 2025, Bengaluru

Organiser



Indian Machine Tool  
Manufacturers' Association

Venue



Bangalore  
International  
Exhibition Centre



[www.imtex.in](http://www.imtex.in)

# SETTING THINGS IN MOTION

Nestled in the beautiful landscape of Alps mountains, Fritz Studer AG organized its most-awaited Motion Meeting 2024 at its Steffisburg facility in Switzerland. This year's edition marked the company's journey of 111 years as well as celebrated the achievement of a successful 2023 fiscal year that exceeded the company's sales targets.



L-R: Daniel Huber, CTO; Jens Bleher, CEO; Sandro Bottazzo, CSO; and Stephan Stoll, COO, Fritz Studer AG during the Motion Meeting 2024 in Thun.

Source: Magic Wand Media

**W**oven around the theme of 'The Sound of Studer', this year's Motion Meeting was all about celebrating achievements. Taking pride in the company's continued success, Jens Bleher, CEO, Fritz Studer AG, noted that consistent investments in product development and site infrastructure have paid off. "We have turned our announcements into reality and used the time to improve our market po-

sition and strengthen ourselves for the future in the long term," he shared.

### Breaking records

According to Bleher, Studer could gain market share in many regions of the world. Amid a globally challenging investment environment, the company was successful in increasing its sales, especially in markets like the USA and China where the sales revenue peaked.

On an optimistic note, Bleher stated that the company's new sales record in the Customer Care segment is highly encouraging and indicates a positive sign for the upcoming fiscal year. He said, "The order situation developed exceptionally well towards the end of the year."

Sharing insights into the company's recent record-breaking sales achievements, Sandro Bottazzo, Managing Director & CSO, Fritz Studer AG, remarked, "We

MURALI SUNDARAM  
Correspondent  
Magic Wand Media Inc  
murali.sundaram@  
magicwandmedia.in



achieved good results in many countries and even posted a new record order intake in some.” The orders for CNC universal cylindrical grinding machines were very solid. The machine with the highest volume was the S33, followed by the favorite CNC, the S31, the S41, and the favorite. “When it comes to internal cylindrical grinding machines, it was the third-best year for incoming orders in the company’s history for the S131. Orders for the new S100 internal cylindrical grinding machine were also very pleasing and exceeded targets,” stressed Bottazzo.

### Crucial industry segments

Elaborating on the industry sectors in terms of order intake, he said that measured by customer segments, the Aerospace industry generated the largest increase in new orders and has now overtaken the Automotive industry. The largest individual segment is precision engineering, which is dominated by contract manufacturers. The Mechanical Engineering and Die & Mold segments also maintained their important positions in terms of orders. The company witnessed an increasing demand for precision cylindrical grinding machines in the Semiconductor industry as well.

Daniel Huber, CTO, Fritz Studer AG, remarked on the significant potential within the Semiconductor industry. “The demand



L-R: Prabhakar H, National Head – Sales & Business Development, Cylindrical Grinding Machines, United Grinding Group India; Pascale Keller, Sales Assistant, Fritz Studer AG; and Rolf Gossenbacher, Sales Director, Fritz Studer AG; at the rewards and recognition ceremony in Thun.



Source: Magic Wand Media

(2<sup>nd</sup> from L): Dr Emil Sauter from the Institute for Manufacturing Technology and Machine Tools at ETH Zürich bagged the Fritz Studer Award 2023 for Innovative Grinding Technologies.

for high-performance semiconductors is rising due to e-mobility and photovoltaics.”

Speaking on catering to the MSME and SME customers, Bottazzo mentioned the company’s grinding machines that are highly trusted by small- and medium-sized enterprises. “This segment remains strategically important for us,” he noted.

### Sustainability matters

Providing an outlook for the future, Huber shared, “The issue of sustainability continues to be important for us. The SmartJet® cooling system developed by Studer significantly reduces the need for coolant and energy in the grinding process, setting new industry standards.” He concluded, “In the long term, only the machine manufacturers who offer intelligent and efficient machines incorporating the latest technology can be successful.”

### Meticulous operations

Elaborating on the focused operations strategy of the company, Stephan Stoll, COO, Fritz Studer, stressed, “The production-mix of the machines manufactured has shifted to more complex systems in 2023. Due to active procurement management and the normalization of global supply chains, orders were completed on time.”

“The implementation of the joint production strategy within the United Grinding Group, provided Studer with good utilization. Key operational projects included investments in automated manufacturing tools and state-of-the-art test stands. Studer is one of the few grinding machine manufacturers to produce its own high-quality spindles. The expertise for these strategically important machine components was specifically expanded. Comprehensive structural and logistical measures were further invested in Steffisburg and the internal grinding competence center in Biel for these prerequisites and further growth,” he further added.

### Industry academia

Fritz Studer AG is well known for working closely with academia and encouraging young talents to make breakthrough R&D projects. In this edition of Motion Meeting, the Fritz Studer Award 2023 for Innovative Grinding Technologies was awarded to Dr Emil Sauter from the Institute for Manufacturing Technology and Machine Tools at ETH Zürich. The prize money was CHF10000. His topic was ‘Detection and avoidance of thermal damage for high-performance metal grinding processes using hybrid machine learning models.’ 

Studer witnessed successful sales of system machines and high-end products in India lately. The company is optimistic about the future prospects, anticipating continued growth in the Indian market throughout 2024.

## SHAPING THE FUTURE OF MANUFACTURING

Held at Kay Bailey Hutchison Convention Center, Dallas, Texas in February, the 25th Anniversary of Dassault Systèmes’ annual event for the SolidWorks and 3DEXPERIENCE Works community—3DEXPERIENCE World 2024—was a confluence of industry giants, end-users, business leaders, and entrepreneurs. This year’s theme focused on innovations, sustainability, and how 3DEXPERIENCE Works enables product and process redesign for a better world.



Source: Magic Wand Media

In his opening address, Charlès mentioned the change of leadership, with Pascal Daloz having taken over the CEO’s role on January 1, 2024, and highlighted Daloz’s contribution to stimulating the culture of innovation.

**W**oven around the latest manufacturing technologies like Artificial Intelligence (AI), Collaborative Innovation, Virtual Twins, Digital Transformation, and many more interesting trends, the event hosted 4,700 attendees from over 30 countries at its 25<sup>th</sup> edition.

Declaring the show open, Gian Paolo Bassi, Senior Vice President, 3DEXPERIENCE Works, Dassault Systèmes, remarked, “For 25 years, our ‘World’ events have provided opportunities to celebrate attendees and facilitate community engagement while imagining all we can achieve in

the future, together.” “3DEXPERIENCE World 2024 builds on this story of innovation, thought leadership, customer success, products, and experiences. Now more than ever, we are connected in a world where the virtual makes it possible to push the limits of the imagination. We will continue to empower this global community to imagine the possibilities ahead, with our 3DEXPERIENCE platform,” he further added.

### Blueprint for design productivity

Presenting the Vision for Future, Bernard Charlès, Chairman,

Board of Directors, Dassault Systèmes, highlighted the company’s roadmap for 2024, encompassing transformative technologies, i.e., generative AI, and cloud-based solutions. He emphasized the need to reinvent the design processes to address sustainability and waste management challenges and demonstrated an innovative approach that includes AI-driven modeling and simulation designed to transform product lifecycle management. He announced that the new AI-empowered design experiences will be available in all Dassault Systèmes design apps by the end of the year.

MURALI SUNDARAM  
Correspondent  
Magic Wand Media Inc  
murali.sundaram@  
magicwandmedia.in





L-R: Alok Das, Co Founder, QARGOS and Pranav Shinde, Lead Engineer For Research and Development, QARGOS

### Artificial Intelligence making inroads

Manish Kumar, CEO, SOLIDWORKS and R&D Vice-President, Dassault Systèmes, explained how the 3DEXPERIENCE platform enables users to not just locate that proverbial needle in the haystack but to find alternative parts, or perhaps even new suppliers. “We use AI to help you identify the right action that you must take,” he noted.

He further elaborated, “Once users put their data on the 3DEXPERIENCE platform, they no longer have to deal with complex, interconnected data. The platform provides users with freedom from data organization, safety, security, backups, locations, and devices. You can now deliver AI-driven organization to your data, allowing you to focus on what truly matters: innovation.”

### Success stories galore

Well-known for facilitating innovation among end-users, Dassault Systèmes featured innovative exhibits from myriad industry sectors and different parts of the world at the play area. Team MMI met two Indian companies—QARGOS and Tigoona Mobility—that showcased their breakthrough products at the event.

### QARGOS

At 3DEXPERIENCE World 2024, Alok Das, Co-founder, QARGOS, introduced the world’s first cargo scooter platform. The Bengaluru-

ru-based company aims to revolutionize the way logistics operate. Powered by the 3DEXPERIENCE platform, QARGOS’s cargo scooter platform exemplifies cutting-edge design and engineering. He recounted the journey from initial sketches on SOLIDWORKS to the platform’s debut on the global stage. Addressing fellow entrepreneurs, Das urged startups to explore Dassault Systèmes’ startup program for invaluable support and guidance. He credited the program with propelling QARGOS on the world stage and emphasized the importance of collaboration in accelerating innovation.

### Tigoona Mobility

Abhijit Bansod, Founder and Principal Designer, Tigoona Mobility Pvt Ltd, shared insights into the company’s mission and innovative approach to street vending. He elaborated on the significant role of the 3DEXPERIENCE platform in Tigoona’s journey and how it helped them reach beyond the limits while working within the boundaries of cost limits. By simulating product performance and optimizing packaging for Indian road conditions, Tigoona achieved significant time and cost savings, accelerating product development and prototyping.

### XOTO Inc.

Tim Hunter, Founder & Designer, XOTO Inc., a company specializing in innovative electric light utility vehicles, highlighted the significance of using SOLIDWORKS software for designing the suspension system and emphasized the quick transition from design to manufacturing, thanks to the software’s capabilities in prototyping and real-world testing.

### Tormach Inc.

Steven Courchane, Technical Pre Sales Engineer, Tormach Inc., delved into the innovative features of the Tormach 1100MX



Abhijit Bansod, Founder and Principal Designer, Tigoona Mobility Pvt Ltd

CNC Mill, showcasing its compact and powerful design. Highlighting 3DEXPERIENCE’s pivotal role as a platform for improving productivity and sustainability in CNC machining, he emphasized how it empowered him to model intricate fixturing and streamline the machining process, even without a five-axis machine.

### CADTech USA

Hamza Darugar, 3D Technology Specialist, CADTech USA, discussed the process of preparing critical final outputs in 3D modeling applications. He elaborated on the connectivity between various elements in the 3DEXPERIENCE, emphasizing the role of Arctec 3D technology and its integration with software like SOLIDWORKS.

### Enhancing productivity

Craig Serkanic, Industry Process Consultant, 3DEXPERIENCE Works, DELMIA Machining, explained how the Virtual Twin concept facilitates connectivity between the machine and the software, enabling live kinematics and virtual simulations within the same platform.

He explained the role of the 3DEXPERIENCE platform in tracking machine uptime, downtime, spindle time, and tool change time. Talking about productivity improvements, Serkanic emphasized the platform’s ability to streamline operations, reduce setup time, and increase efficiency through unified modeling and simulation capabilities. 

The next edition of 3DEXPERIENCE World 2025 will be held in Houston, Texas, at the George R. Brown Convention Center from February 23-26, 2025.

## Company Index

Ace Designers Ltd.....	24	Kirloskar Systems Ltd.....	64
ACMA.....	24	KNOLL Maschinenbau GmbH.....	44
AMADA India Pvt Ltd.....	64	Laser Technologies Pvt Ltd.....	64
AMPCO METAL India Pvt Ltd.....	64	Messer Cutting Systems India Pvt Ltd.....	64
ANDREAS MAIER Workholding Technology Pvt Ltd.....	64	Milacron India Pvt Ltd (MIPL).....	56
Bajaj Engineering Skills Training (BEST) Centre.....	62	NN Combined Engineering Agencies Pvt Ltd.....	44
Carborundum Universal Ltd.....	28	Planet Computers Ltd.....	16
CERATIZIT Austria.....	44	RadCAM Technologies Pvt Ltd.....	64
Dassault Systèmes.....	72	RV Forms & Gears.....	16
Electropneumatics & Hydraulics India Pvt Ltd.....	24	Sahajanand Laser Technology Ltd (SLTL Group).....	64
Fritz Studer AG.....	70	Sandvik Coromant.....	24
Grind Master Machines Pvt Ltd.....	24	SASTRA Deemed to be University.....	62
IMTMA.....	06, 08, 12, 14, 24, 38, 64	Scansonic GmbH.....	60
IND-Sphinx Precision Ltd.....	38	Subros Ltd.....	24
ISGEC Heavy Engineering Ltd.....	38	Titan Company Ltd.....	64
ITL Industries Ltd.....	38	Toyota Kirloskar Auto Parts Pvt Ltd (TKAP).....	48
Jyoti CNC Automation Ltd.....	38, 64	WIKA India.....	20
Kennametal India Ltd.....	54	Yamazaki Mazak Pvt Ltd.....	16
Kirloskar Ferrous Industries Ltd (KFIL).....	34		

## Advertiser Index

EPLAN Software & Services Pvt Ltd – <a href="http://www.eplan.in">www.eplan.in</a> .....	11
HIMTEX 2024 – <a href="http://www.hitex.co.in">www.hitex.co.in</a> .....	33
IMTMA – FACTEQ 2024 – <a href="http://www.facteq.in">www.facteq.in</a> .....	59
IMTMA – IMTEX 2025 – <a href="http://www.imtex.in">www.imtex.in</a> .....	69
IMTMA – Pune Machine Tool Expo 2024 – <a href="http://www.mtx.co.in">www.mtx.co.in</a> .....	53
IMTMA – Manufacturing Technology Training – <a href="http://www.imtmatraining.com">www.imtmatraining.com</a> .....	43
IMTOF 2024 – <a href="http://www.imtof.in">www.imtof.in</a> .....	07
Jyoti CNC Automation Ltd – <a href="http://www.jyoti.co.in">www.jyoti.co.in</a> .....	03
Kennametal India Ltd – <a href="http://www.kennametal.com">www.kennametal.com</a> .....	13
Lakshmi Machine Works Ltd – <a href="http://www.lmwcnc.com">www.lmwcnc.com</a> .....	05
NN Combined Engineering Agencies Pvt Ltd – <a href="http://www.nncea.com">www.nncea.com</a> .....	76
Okuma India Pvt Ltd – <a href="http://www.okumaindia.com">www.okumaindia.com</a> .....	09
RV Forms & Gears LLP – <a href="http://www.rvformsandgears.com">www.rvformsandgears.com</a> .....	75
S&T Machinery (P) Ltd – <a href="http://www.stmcnc.com">www.stmcnc.com</a> .....	02
WIDMA Machining Solutions Group – <a href="http://www.widma.com">www.widma.com</a> .....	21



**MODERN  
MANUFACTURING  
INDIA**

WWW.MMINDIA.CO.IN

THE OFFICIAL MAGAZINE OF



INDIAN MACHINE TOOL  
MANUFACTURERS' ASSOCIATION

PARTNERED BY





Modern  
Machine  
Shop

Yes, I wish to subscribe to  
**MODERN MANUFACTURING INDIA**

1 Year	₹	750
2 Years	₹	1200

### To SUBSCRIBE





**PERSONAL DETAILS**

Company \_\_\_\_\_

Name \_\_\_\_\_

Department \_\_\_\_\_ Designation \_\_\_\_\_

Company Address \_\_\_\_\_

\_\_\_\_\_

City & Pin Code \_\_\_\_\_ Country \_\_\_\_\_

E-mail \_\_\_\_\_ Contact No. \_\_\_\_\_

Industry \_\_\_\_\_

**SUBSCRIPTION PAYMENT DETAILS**

Please find enclosed cheque / DD No.: \_\_\_\_\_

Drawn on (Name of bank & branch): \_\_\_\_\_

Dated \_\_\_\_\_

For Rs. \_\_\_\_\_ Rupees in words \_\_\_\_\_

Favouring **INDIAN MACHINE TOOL MANUFACTURERS' ASSOCIATION**

IMTMA, Bangalore International Exhibition Centre (BIEC), 10<sup>th</sup> Mile, Tumkur Road, Madavara post, Bangalore - 562123  
Tel: 080 - 66246617 [imtma@imtma.in](mailto:imtma@imtma.in)

Sources & Terms of Supply: Orders can be placed directly with the publisher. No claims for the supply of back copies or reimbursement of subscription fees can be entertained for non-delivery of the magazine for reasons beyond the publisher's control.

[www.mmindia.co.in/magazine\\_issues](http://www.mmindia.co.in/magazine_issues)



# SmartFix4.0<sup>®</sup>

## Intelligent Fixtures



Winner of CII Industrial  
Innovation Award 2020



## Asia's leading fixture builder

For over 50 years Forms & Gears has been designing and manufacturing Precision Fixtures to the world's leading Auto OEMs and Machine Makers in 10 countries across the globe.

**RV Forms & Gears LLP**  
MF 11, SIDCO Industrial Estate, Guindy,  
Chennai - 600 032, Tamilnadu, India  
Call +91 77570 53326 or email us on  
[marketing@rvformsandgears.com](mailto:marketing@rvformsandgears.com)  
[www.rvformsandgears.com](http://www.rvformsandgears.com)



# Engineering Solutions and Sales Distribution

Automotive | Aerospace | Medical | Defence | Advanced Materials | Pharma & Food Processing Industries



The leading supplier of Conveyor Systems, Filtration Systems, and Pumps for Metal Cutting processes

**KNOLL**  
.It works



## Product Portfolio

- Cutting Tools
- Machine Tool Accessories
- Pumps & Filtration Systems
- Coolant & Chip Management Systems

- Workholding Solutions
- Superfinishing Solutions for Advanced Materials
- Component Cleaning Solutions
- Custom Engineering Solutions

**Productivity • Technology • Innovation • Expertise • Reliability**



### Suppliers of Quality Products

qual-i-ty Consistent adherence to measurable and verifiable standards to achieve uniformity of output that satisfies specific customer requirements.

Contact Information:  
 NN Combined Engineering Agencies Pvt Ltd  
 First Floor Dr Ranji Block 125 M G Road Secunderabad 500 003 India  
 Internet: [www.nncea.com](http://www.nncea.com) Email: [mail@nncea.com](mailto:mail@nncea.com)  
 Phones: +91 (40) 27844279 / 27898579 / 48502475

