



MODERN MANUFACTURING INDIA

WWW.MMINDIA.CO.IN

The Official Magazine of



Indian Machine Tool
Manufacturers' Association

In Association with



International Machine Tool &
Manufacturing Technology Exhibition
19 - 25 January 2023, Bengaluru, India



COUNTRY FOCUS
India Taiwan

38



COMPANY PROFILE
Excelling in Surface Matters

28



OPEd
Future-proofing the Workforce

12



Intelligent Fixtures

A breakthrough Industry 4.0 solution for Fixtures.



Smartfix 4.0 is a unique Industry 4.0 solution for all types of Fixtures and Workholding which uses Data Analytics and Artificial Intelligence to give the user a lot of useful information like:

- Tool Wear Analytics
- Cost Per Component Analytics
- Vibration Alerts
- Declamp Alerts
- Output of Fixture and Machine
- Predictive Maintenance of Fixture and Machine
- Analytics of Operator Efficiency
- Historical Analysis of performance of machine, powerpack, tools and fixture
- Powerpack oil level and oil contamination alerts

Smartfix 4.0 can be installed on existing fixtures also and is the most cost effective way of making the entire machining set up Industry 4.0 enabled.

SmartFix4.0®

For over 45 years Forms & Gears has been supplying Precision Machining Centre Fixtures to the world's leading Auto OEMs and Machine Makers in Japan, Germany, UAE, Qatar, Thailand, Turkey, Indonesia and all over India.

RV Forms & Gears LLP
MF 11, SIDCO Industrial Estate, Guindy,
Chennai - 600 032, Tamilnadu, India
Call +91 77570 53326 or email us on
marketing@rvformsandgears.com
www.rvformsandgears.com





AUTOMOBILE

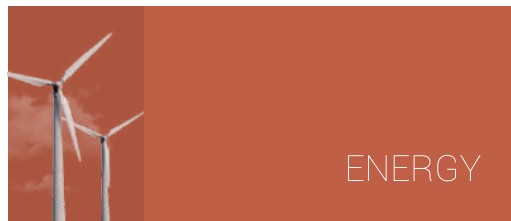

ENERGY



PUMPS & VALVES



DEFENCE



INFRASTRUCTURE



HEALTHCARE

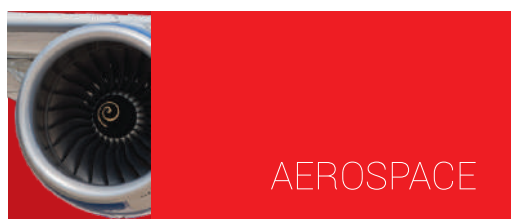

AEROSPACE



OIL & GAS



DIE MOULD



DX Series
Turning & Turn-Mill Center



AX Series
High Precision Turn-Mill Center



VMC Performance Series
Vertical Machining Center



HX Series
Horizontal Machining Center



VTL Series
Vertical Turning Center

JYOTI CNC AUTOMATION LTD.

G – 506, G.I.D.C. Lodhika, Village : Metoda, Dist : Rajkot – 360021, Gujarat (INDIA).

T + 91-2827-235100/101, E info@jyoti.co.in, sales@jyoti.co.in jyoti.co.in

JyotiHuron

CONTENTS

VOL 6, ISSUE 2 - JULY-AUGUST 2022



06	FOREWORD
08	EDITORIAL
10	IMTMA'S DESK IMTEX 2023: Revolutionizing Medical Devices Industry
11	SUBSCRIPTION FORM
12	OPED Future-Proofing the Workforce
16	INDUSTRY TIPS When the Lights are Out
20	INSIGHT Towards an Electric Future
22	COVER STORY Quality Control Matters
28	COMPANY PROFILE Excelling in Surface Matters

31	ROBOTICS The Perfect Robot
33	MANUFACTURING SOFTWARE Competing on a Global Scale
36	DIGITAL TRANSFORMATION Transforming for Growth
38	COUNTRY FOCUS Converging Strengths
41	EVENT SNAPSHOT BFW L-DED Machines Launch
44	EVENT SNAPSHOT IMTEX FORMING 2022
49	COMPANY INDEX & ADVERTISER INDEX

IMPRINT

PUBLISHER

DIRECTOR GENERAL, IMTMA

EDITORIAL

Editor-in-Chief

Soumi Mitra

Chief Copy Editor

Poonam Pednekar

Correspondent

Arunima Nath

Sub-Editor

Sovan Tudu

Design

Magic Wand Media

SALES & MARKETING

Indian Machine Tool Manufacturers' Association
(IMTMA)

Murali Sundaram, Magic Wand Media Inc

murali.sundaram@magicwandmedia.in

Published and Printed by Indian Machine Tool Manufacturers' Association (IMTMA). Printed at Pentaplus Printer's Pvt Ltd 20/1, 4th main, 5th cross, Industrial Town, Rajaji Nagar, Bangalore-560044, Karnataka and Published from Indian Machine Tool Manufacturers' Association; Head Office: 10th Mile, Tumkur Road, Madavara Post, Bengaluru - 562123, Karnataka. Editor: Soumi Mitra

Publishing frequency: 6 times per year

Manuscripts: No liability is accepted for unsolicited manuscripts. They will be returned only if accompanied by sufficient return postage.

All rights reserved. Reprints, digital processing of all kinds and reproduction only by written permission of the publisher. Any views, comments expressed are the sole responsibility of the respective authors, IMTMA and Modern Manufacturing India and its partners do not undertake any responsibility, implied or otherwise.

Disclaimer: Every effort has been taken to avoid errors or omissions in this magazine. In spite of this, errors may creep in. Any mistake, error or discrepancy noted may be brought to our notice immediately. It is notified that neither the publisher, the editor or the seller will be responsible in respect of anything and the consequence of anything done or omitted to be done by any person in reliance upon the content herein. This disclaimer applies to all, whether subscriber to the magazine or not. © All rights are reserved. No part of this magazine may be reproduced or copied in any form or by any means without the prior written permission of the publisher. All disputes are subject to the exclusive jurisdiction of competent courts and forums in Bangalore only. While care is taken prior to acceptance of advertising copy, it is not possible to verify its contents. IMTMA cannot be held responsible for such contents, nor for any loss or damages incurred as a result of transactions with companies, associations or individuals advertising in its newspapers or publications. We therefore recommend that readers make necessary inquiries before sending any monies or entering into any agreements with advertisers or otherwise acting on an advertisement in any manner whatsoever.

SPEED
EFFICIENCY
PERFORMANCE



JH40 ⌚ Upto 12000 rpm

HORIZONTAL MACHINING CENTRE



JV30 Neo ⌚ Upto 24000 rpm

DRILL TAP CENTRE



VERTICAL MACHINING CENTRE

J1 ⌚ Upto 12000 rpm

TURNING CENTRE

Smart
Minimaster
Linear

⌚ Upto 6000 rpm

FEATURES

- Rigid structure
- Better accuracy & surface finish
- High Precision & High speed spindle
- Ergonomic & compact design for easy maintenance



INDIA'S FINEST
RANGE OF CNC MACHINES

FOLLOW US ON:



LMW CNC



INTEGRATED SOLUTIONS

LAKSHMI MACHINE WORKS LIMITED

MACHINE TOOL DIVISION

A STABLE OUTLOOK



Source: BEW

RAVI RAGHAVAN
PRESIDENT
INDIAN MACHINE TOOL
MANUFACTURERS' ASSOCIATION
(IMTMA)

Dear Readers,

Policy changes in India are always expected to have a lasting impact on the Manufacturing industries worldwide. India's response to fiscal, monetary, and health adversities has helped it mitigate many uncertainties.

The country's manufacturing PMI (Purchasing Managers' Index) has been consistently hovering over 50 PMI points for many months, indicating an economic expansion and improvement in manufacturing. India's services activities also expanded rapidly, moving to 59.2 PMI in June, according to S&P Global India Services PMI Business Activity Index.

With regard to technology and product development, industries are reaching out to work closely with the Ministry of Heavy Industries, Government of India, besides self-funded R&D initiatives.

Under the Scheme of 'Enhancement of Competitiveness in the Indian Capital Goods Sector - Phase II', companies are developing products and technologies to enhance manufacturing competitiveness. I urge industries to make optimum use of the scheme.

Globally, with the geopolitical crisis unfolding, the increasing cost of raw materials is posing challenges. However, industries, especially the Auto sector in the electric two-wheeler and three-wheeler segments, are doing satisfactory business.

Industry sectors such as Railways, Infrastructure, Renewable Energy, Aerospace and Defence, Toy Manufacturing, Furniture Manufacturing, and so on are stepping up capital investments. All these augur well for the Machine Tool industry business.

The recent successful trade shows held at our Bangalore International Exhibition Centre (BIEC) have rejuvenated business confidence and the Exhibition industry outlook. The

industry now eagerly awaits IMTEX 2023 & Tooltech 2023, along with Digital Manufacturing, which is scheduled for January 19-25, 2023, at BIEC, Bengaluru. There's a significant optimism and interest among industries, and IMTEX 2023, in its physical avatar after a gap of four years, is expected to further fuel India's aspirations of becoming a global manufacturing hub.

Industry sectors such as Railways, Infrastructure, Renewable Energy, Aerospace and Defence, Toy Manufacturing, Furniture Manufacturing, and so on are stepping up capital investments. All these augur well for the Machine Tool industry business.



Let's focus on Workflows.

EPLAN Platform 2022

It's in your hands!

Let's focus on workflows.

EPLAN Platform connects software solutions from every engineering discipline – from preplanning and project planning to the design of switchgear and cable harnesses. The demand in engineering and the associated workflows are constantly getting more complex and individual customer requirements must be implemented in schematics documentation as quickly as possible. With the EPLAN Platform 2022, we have modern tools for your daily work and the engineering of tomorrow.

Our Solutions

- I. EPLAN Platform 2022 provides you an opportunity to structure your workflows in a targeted manner and to systematically increases the productivity of your processes.
- II. EPLAN Cloud integration offers you with added value for integrated workflows
- III. EPLAN Platform 2022 offers you to book eLearning trainings
- IV. With EPLAN Dataportal you will benefit from significant time savings that will positively impact your projects, starting from preplanning through to commissioning.

Contact **Ms. Sindhu Krishnappa** to know how to make your Engineering Efficient.

+91 96865 50509 sindhu.k@eplan.in

www.eplan.in info@eplan.in



Soumi Mitra

SOUMI MITRA
Editor-in-Chief
Modern Manufacturing India
soumi.mitra@magicwandmedia.in

CHOOSING GROWTH AGAIN

It is a matter of immense pride to look back at India's growth journey on the eve of Independence Day. To begin with, the country saw the highest annual Foreign Direct Investment (FDI) inflow of US\$83.57 billion in the last fiscal and rapidly continues to emerge as a preferred investment destination for manufacturing.

The FDI Equity inflow in the Manufacturing sector increased 76 percent in FY 2021-22 (US\$21.34 billion) compared to the previous FY 2020-21 (US\$12.09 billion).

As per Government figures, FDI inflows have increased 20-fold in the last 20 years. Interestingly, Post-COVID-19, FDI inflows saw an increase of 23 percent. The latest FDI figures endorse India becoming a preferred investment destination among global investors.

To make the Indian Manufacturing sector more competitive, the Government has announced an investment of US\$1.5 billion in the next five years to increase the country's share in global exports of manufactured goods from 2-3 percent. The Government investment will contribute to boosting the growth rate.

Lately, manufacturing exports witnessed a growth of over 40 percent touching US\$418 billion in the fiscal year 2021-22, compared to the US\$290 billion from the previous year.

According to a global think-tank report, the Indian economy is likely to grow by 7.1 percent in the current fiscal. Major contributions will be from the Services, Manufacturing, and Farm sectors. India's manufacturing exports are slated to

scale up and touch US\$1 trillion by the fiscal year 2027-28.

"If you are seizing on a new business opportunity, deliberately move your customers' expectations up a few notches and consistently over-deliver on your promises - you will leave your competitors struggling to catch up."

- Richard Branson

In this favorable atmosphere of exponential growth in the Indian manufacturing sector and India's manufacturing exports, IMTMA's flagship International Machine Tool and Manufacturing Technology Exhibition - IMTEX 2023 & Tooltech 2023 - will take place from January 19-25 at Bangalore International Exhibition Centre (BIEC). The much-awaited South Asia's Apex metal cutting show will feature a wide array of advanced machine tool trends and manufacturing technologies.

Looking forward to meeting you at this spectacular in-person show that is taking place after a hiatus of two years.

Fanless and powerful: C6025 ultra-compact Industrial PC

Fanless
Intel® Core™ i power



C6015



C6017

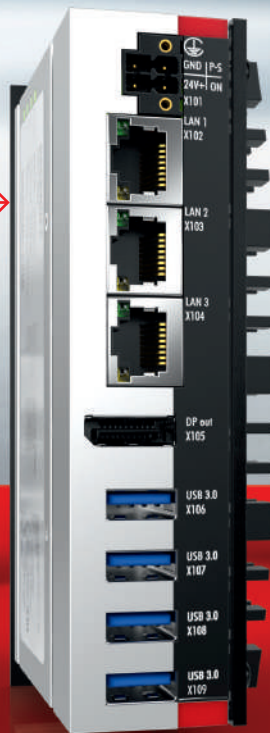

C6025



C6030



C6032

www.beckhoff.com/c6025

As a powerful member of the ultra-compact Industrial PC family from Beckhoff, the C6025 allows flexible installation and is designed as a fanless device which, despite its compact dimensions of 82 x 127 x 40 mm, offers exceptionally high computing power. This performance is delivered based on the Intel® Core™ i U processors with up to four processor cores and significantly reduced energy requirement. Even in the basic version, the C6025 offers 4 GB DDR4 RAM and 40 GB M.2 SSD as 3D flash memory (both expandable), a DisplayPort and four USB 3.0 ports, as well as an on-board Ethernet adapter. This feature set enables the cost-effective implementation of demanding control applications as well as advanced gateway or communication tasks.



BECKHOFF ENABLING
MADE BY
INDIA

Beckhoff Automation Pvt. Ltd.
Pune – 411 001, India
Phone: +91 (20) 6706 4800
info@beckhoff.co.in

New Automation Technology

BECKHOFF



IMTEX 2023: REVOLUTIONIZING MEDICAL DEVICES INDUSTRY

The Indian machine tool industry has been supporting the medical sector by developing the required machinery and equipment. The upcoming IMTEX 2023 is to bring forth the advancements in the sector and the potential it holds for the machine tool industry.



Source: Magic Wand Media

The COVID-19 pandemic, critical illnesses like cancer, the growing demand for home monitoring medical devices and instruments for high-end surgeries, etc., is leading to heightened demands from the medical devices industry for sophisticated medical equipment. Globally, as well as in India, technological advancements and the Internet of Medical Things (IoMT) are modernizing the healthcare segment, leading to a surge in demand for products and services from the Machine Tool industry. The contribution of the Indian Medical sector came to the fore during the pandemic, with many firms manufacturing medical devices and diagnostic kits. The industry, however,

needs to keep itself on top in terms of accessibility, affordability, safety, and quality, besides keeping itself self-sustainable and innovative.

Size of the medical devices market

According to a report by Astute Analytica, the global medical devices market is expected to cross US\$625 billion by 2027. The Indian medical devices market was valued at around US\$10 billion in 2020 and is expected to reach around US\$50 billion by 2025, according to the Government of India estimates. In terms of the market size, India ranks among the top 20 markets in the world for medical devices, and the country is the 4th largest in Asia, ranking just below Japan,

China, and South Korea. The sector has been growing consistently at a CAGR of around 15 percent in recent years.

Investments and imports

As per the Government of India's estimates, there are around 750-800 domestic medical device manufacturers in India, with an average investment of US\$2.3-2.7 million and an average turnover of US\$6.2-6.9 million. Around 65 percent of the manufacturers are domestic players operating in consumable segments meeting domestic needs.

India imports high-end medical equipment; more than 75 percent of the medical devices used for diagnostic and testing are imported from the US (21%), Germany (14%) Singapore (11%), and China (10%).

Government initiatives

The Government of India has identified the Medical Devices industry as one of the champion sectors and, through PLI schemes, is providing incentives for select critical care categories such as cancer care/radiotherapy, cardio-respiratory, renal care, and all implants. It has also allowed 100 percent foreign direct investments (FDI) to boost the sector.

To support the domestic manufacturing of medical devices in India, the Ministry of Chemicals and Fertilizers has launched a scheme for 'Promotion of Medical Devices Parks' with an outlay of ₹400 crore. As per the Ministry, the scheme aims to significantly reduce manufacturing costs, optimize resources, and provide easy access to standard testing and infrastructure facilities.

Buoyed by the announcement of the scheme, Himachal Pradesh, Tamil Nadu, Madhya Pradesh, and Uttar Pradesh have given green signals to set up medical device parks. Medical device parks are also coming up in Andhra Pradesh, Telanga-

na, Tamil Nadu, and Kerala, all of which are under various stages of development.

Role of machine tool industry

The Indian Machine Tool industry has been supporting the Medical sector by developing the required machinery and equipment. High-precision turning and milling machines, laser-based cutting, welding and ablation machines, micro-machining centers, surface engineering technologies, super finishing machines, lapping machines, and abrasive flow finishing machines are used for making medical parts. Special Purpose Machines (SPMs) for medium- to large-sized parts required for medical devices are all manufactured by the Machine Tool industry.

As we understand, Bharat Electronics Ltd (BEL) is manufacturing ICU ventilators in partnership with Skanray Technologies with design support from Defence Research and Development Organisation (DRDO). This is a unique example of the public and private sectors coming to-

gether for manufacturing. When such equipment is manufactured indigenously, it carries distinct advantages, which are primarily cost-focused benefits. Such advancements are certainly game changers for the Medical Devices industry in India.

IMTEX propelling medical devices sector

IMTEX is one of the largest exhibitions in the world showcasing advancements in machine tools manufacturing. The exhibition is a platform for various stakeholders to witness technologies in a live format and arrive at the right decisions. Indian Machine Tool Manufacturers' Association (IMTMA) is organizing IMTEX along with Tooltech and Digital Manufacturing on January 19-25, 2023, at Bangalore International Exhibition Centre (BIEC). The exhibition will be a significant opportunity for the medical equipment manufacturers to network with the global machine tool fraternity, and experience and procure the technologies for their manufacturing requirements. 

IMTEX 2023 will be a significant opportunity for the medical equipment manufacturers to network with the global machine tool fraternity, and experience and procure the technologies for their manufacturing requirements.



WWW.MMINDIA.CO.IN

THE OFFICIAL MAGAZINE OF

PARTNERED BY



SUBSCRIBE THE PRINT MAGAZINE AND GET THE DIGITAL FREE!



www.mmindia.co.in/magazine_issues

Yes, I wish to subscribe to MODERN MANUFACTURING INDIA	1 Year <input type="checkbox"/> ₹ 750
	2 Years <input type="checkbox"/> ₹ 1200

PERSONAL DETAILS

Company _____
Name _____
Department _____ Designation _____
Company Address _____

City & Pin Code _____ Country _____
E-mail _____ Contact No. _____
Industry _____

SUBSCRIPTION PAYMENT DETAILS

Please find enclosed cheque / DD No.: _____
Drawn on (Name of bank & branch): _____ Dated _____
For Rs. _____ Rupees in words _____

Favouring **INDIAN MACHINE TOOL MANUFACTURERS' ASSOCIATION**

IMTMA, Bangalore International Exhibition Centre (BIEC), 10th Mile, Tumkur Road, Madavara post, Bangalore - 562123
Tel: 080 - 66246617 imtma@imtma.in

Sources & Terms of Supply: Orders can be placed directly with the publisher. No claims for the supply of back copies or reimbursement of subscription fees can be entertained for non-delivery of the magazine for reasons beyond the publisher's control.

FUTURE-PROOFING THE WORKFORCE

Digital technologies are disrupting India's manufacturing industry, which has huge job potential. Industry experts discuss the importance of enhancing employees' soft skills through digital tools to shape the industry's future, and the key skill sets hiring managers look for in potential employees.



K Ganapathi Subramanian
Vice President, Marketing & Sales
Gedee Weiler Pvt Ltd

Manufacturing is all about teamwork; when everyone performs their role and integrates with the team, the operation runs smoothly and efficiently. The work in manufacturing can be demanding, repetitive, and time-sensitive, and you may have to work long and unsociable hours. Therefore, to thrive in the Manufacturing industry, you need to develop a strong work ethic and always be able to put in 100 percent at work.

Managing time and workload

Most roles involve a lot of different tasks. Hence, managing your time well and putting things in the right order is essential. The work can be fast-paced and precise, so attention to detail is vital for performing tasks and working safely in a potentially dangerous environment.

Problems can constantly arise; being able to think critically and quickly is a skill that will help you get ahead. When you work in manufacturing, you are a small yet integral part of the daily operation. Therefore, dependability is a vital quality looked for in employees in the Manufacturing industry.

Ours is an industry that relies heavily on technology and equipment, so it is critical that those who are seeking to get into it have a natural aptitude for them so that they can be trained quickly and become comfortable with the relevant technology and equipment.

Skilling and reskilling

Today, every company is a potential digital enterprise. This is a critical phase in the industrial evolution marked by computers, mobile devices, internet connectivity, data, robotics, 3D technologies, augmented reality, cloud computing, and a host of other developments that are shaping the new age of workplace skills in the Manufacturing sector.

However, advanced technologies do not mean human replacement—instead, new human skills are required. To navigate these new waters, reskilling and upskilling existing workers will be crucial and, if done right, will save companies time and money while continuing to meet the

evolving demands of consumers. Skilling must be intentional, demonstrable, and active. Sessions should be interactive and include periodic assessments to test how employees grasp new skills.

Focusing on sub-skills

Digital technologies can enhance training on multiple fronts. Skills like using a tablet, mobile phone, or computer to take simulated recruitment tests for various sub-skills should be taught. These include the fundamentals of human-computer interaction, the use of touch screen interfaces, overcoming digital anxiety and phobia, playing digital games, performing simulated tasks, and so on.

Second, digital training tools improve training speed and retention. They can be designed to target the most difficult parts of tasks and are optimized for learners who need visual and experiential support. At the end of this transformation process, successful industrial companies will become true digital enterprises, with physical products at their core, augmented by digital interfaces and data-based, innovative services. These enterprises will work together with customers and suppliers in industrial digital ecosystems.

SOVAN TUDU
Sub-Editor
Magic Wand Media Inc
Sovan.tudu@
magicwandmedia.in





Syed Feroz Mehdi
Director, International-Operations
ICAD

ICAD started off as a Technology Integrator, however with the acquisition of AMG Systems in the UK, we have joined as the largest and only ICT manufacturer in the UK. We are also starting the manufacture of decorative lights in Cyprus under the auspices of ICAD Europe. Similarly, we are looking to acquire seaplane manufacturers in the US.

For prospective employees, we would look for people with a passion to excel, intuitive design capabilities, knowledge of global market trends, a grip on the local and international market requirements/demands, capability to think out of the box, and excellence in modern design tools and software.

Staying updated with the latest technologies

It is extremely important for all employees, irrespective of sector, to keep abreast with the technologies of their field, global trends, and market requirements. Upskilling and re-skilling is not a choice, but a necessity for any sector or vertical. Given how the Manufacturing industry is expected to be valued at US\$125 trillion by 2025, it is essential for the workers to receive training in handling crises efficiently. As technology is developing

at a rapid pace, learning more than one technical skill and being adept in artificial intelligence is pertinent for workers to strike the apt balance between human touch and machine learning.

Reskilling from the grassroots level could be a challenge. But this will help us keep up with the industry's skyrocketing competition and automation. It's no surprise that the mechanical age is here to stay. However, the need for cognitive and social skills will always be essential for workers to thrive and shape the nation into a technological superpower.

Digital tools bolster soft skills

Modern companies treat their workers as their greatest resource. Only those companies that value their human assets and constantly work towards the upgradation of their soft skills can survive in the market today. By utilizing technologies that are applicable to their scope of work, they can maximize available potential without increasing the cost. This makes the ventures profitable while retaining the best minds/talents in their workforce.

Improving one's ability to communicate effectively and one's capacity for analytical thought may, in the long run, be of use in promoting both personal and professional development. Employees can only feel confident about their decision-making abilities and digital know-how if they have been encouraged to be innovative from the very beginning of their training years. If we make an early investment in their development, we can have peace of mind knowing that India's future will be led by dynamic leaders who are still in the process of maturing.



Lalit Shankar Kushwaha
Director - Operations, India
Quaker Houghton India

The Manufacturing sector in India is undergoing rapid change, with emerging technologies taking the center stage in developing a new generation of products. It has thus become necessary for employees to match up to the new skill requirements of organizations. While learning and skilling have always been important, constant skill upgradation has acquired new importance in the ongoing global scenario, especially with the advent of Industry 4.0, which seeks to redefine the sector through the use of Artificial Intelligence (AI), Machine Learning (ML), Virtual Reality (VR), and Augmented Reality (AR). India, with its large base of skilled manpower and favorable demography, is best positioned to take advantage of Industry 4.0 and become an industrial and technological superpower.

At the cusp of innovation

The new automation revolution will have a major effect on employment. Nearly every job will change, and that will require employees to develop new skills. There is an increase in demand for social, behavioral, and cognitive skills. Soft skills tend to be more personality-focused and include people skills, social skills, interpersonal

al skills, and transferable skills. The most in-demand soft skills include leadership skills, communication, collaboration, and time management.

Individuals who exhibit both technical know-how and new-age soft skills will benefit the most from the current trend, as organizations are looking for employees with holistic skills. Indian industry experts realize that we are at the juncture of endowing the world with innovation not only in technology but with skilled manpower that is willing to learn, unlearn, and relearn. Today's workforce has become more tech-savvy, and concepts like digitalization as well as Industry 4.0 certainly complement each other.



Rajkumar Ravuri
Director - Manufacturing
Salesforce India

In recent years, the shift from assembly-line manufacturing to technology-driven manufacturing has changed the way companies hire prospective employees. As manufacturing facilities and workspaces are constantly changing due to technological advancements, employers are more likely to hire individuals who are skilled in digital technologies.

For instance, the Manufacturing industry in India is relatively new to digitalization. But we all know how important it is to the future of work. To im-

plement and make efficient use of new digital marketing systems or sales platforms, you need talent that can work with data and analytics, which for many manufacturers is foreign territory. In these scenarios, talent brings with it new and emerging skill sets. At the same time, training, reskilling, and enablement of existing employees is also imperative.

Manufacturers today need to embrace the future by being innovative, adaptable, and change-management-focused. In many cases, attracting the right talent isn't only a case of upgrading systems, technologies, and processes; it's about creating appropriate roles that enable those upgrades.

Filling the skills gap

Re-skilling the workforce is one of the most significant challenges and opportunities we face at this moment. There was a growing digital skills gap before the pandemic. However, with the importance of digitalization in rebuilding the economy and society, that gap has gotten even greater. As per insight from the Digital Skills Index, India leads in digital skills readiness with 72 percent of respondents in India actively learning new digital skills now.

An entirely new set of skills such as 3D printing, Internet of Things (IoT), and robotics are causing massive changes in the Manufacturing sector, which means that manufacturing system employees must deal with manufacturing in a fundamentally different way. To address the growing skills gap, companies must invest in enabling their workforce to learn the skills they require for their jobs now and in the future. We support the skilling imperative via an extensive list of important platforms, projects, initia-

tives, and investments that offer something for everyone. For example, Trailhead, Salesforce's free online learning platform, democratizes digital learning by helping participants with low technical knowledge obtain a Salesforce role in as little as six months.

Individuals who possess both technical knowledge and new-age soft skills stand to benefit the most from the current trend, with companies eager to hire professionals with a comprehensive skill set. Organizations that build work environments where everyone can thrive are equally likely to be the most resilient in the future as they begin new ways of working.

Deepening relationships for growth

Forward-thinking manufacturers are defining, developing, and rapidly accelerating digitization to compete on the most important market differentiator: their ability to understand, engage, and earn the trust of their ecosystem. These companies put their employees first.

While not all manufacturing jobs will necessarily require extensive training in software development or IT, they will require knowledge of digital technologies and systems. Manufacturers are commencing their journeys toward digital transformation. It has become critical to provide a differentiated customer experience while remaining profitable. According to our latest State of Sales research, 74 percent of sales leaders in manufacturing say that digital transformation is accelerating for them. They are investing in technology to do something very human—deepen relationships—and as a result, they're growing.

Manufacturing, despite its me-

chanical complexity, remains a human industry in many ways. Humans are present in every aspect of manufacturing, creation, marketing, selling, coordinating, and everything in between. As a result, one can agree that soft skills such as critical thinking, interpersonal relationship building, ability to manage others, persuasion, and empathy will become increasingly important in the coming years. Many believe that manufacturers who learn to use digital tools to enhance workers' soft skills will make the most progress.



Sougandh KM
Country Manager of India
Universal Robots

For centuries, the Manufacturing industry has been heavily dependent on manual labor. Basic skill requirements include conducting physical tasks like weight lifting and carrying items from one place to another. However, as automation penetrates many aspects of the Manufacturing industry, there will be significant shifts in the skill profiles of manufacturing jobs. The manual and dangerous tasks that were once completed by human labor are now conducted by collaborative robots, or cobots. Cobots relieve human workers from heavy weightlifting and rigorous repetitive tasks, so they can focus on higher-value tasks.

With cobots working on manual tasks, manufacturing hiring managers are now looking for soft skills in employees such as creativity, cognitive skills, and social skills. Nonetheless, this does not imply that companies replace their existing employees with machines. Unlike traditional industrial robots that require professional engineers to operate, cobots are easily programmable. Even employees with no robotic background are capable of handling a cobot.

Skilling for efficiency and productivity

With emerging technologies, more and more machines (such as cobots) are being deployed in the Manufacturing industry, which requires skilled workers for their operation. The focus has shifted from basic survival skills to skills like resilience, critical thinking, and quick decision-making in the workforce. These skills can be given to employees through training and re-training, as well as skilling and reskilling. Training and skilling of employees are among the most pressing priorities to generate higher efficiency and productivity.

As robotics education becomes more prevalent, there is a greater need for human-machine collaboration. Universal Robots introduces the UR Academy, where learners, employees, manufacturers, and career seekers can learn basic robotic skills through free online training modules, webinars, and video tutorials. Moreover, technical skills need to be introduced by the manufacturers to keep pace with the changing times.

Soft skills for a competitive edge

The exponential growth in technology has changed the face of the world. Cobots are relieving human workers from dull,

dirty, and dangerous tasks. Cobots have taken the stage and are transforming operations worldwide. This drives the importance of having a skilled workforce with the right technical training. Reskilling and training play a very pivotal role not only in the growth of employees, but also in increasing an organization's efficiency and productivity.

Skill up-gradation is important in the current global scenario, especially since the advent of Industry 4.0 with automation, machine learning, and different digital processes of manufacturing.

Amplifying workers' soft skills gives companies a competitive edge in the market. Moreover, to ensure all employees are keeping pace with the advances, industry leaders need to quickly embark on retraining and reskilling initiatives. For instance, Hyundai Induction Hardening Heat Treatment (HIHHT) installed two UR10 cobots in its production line. This resulted in a decrease in the failure rate from 0.03 percent to 0.01 percent and an increase in production efficiency by 31 percent. Additionally, automating the production processes allows HIHHT to hire two more employees. 

Modernization in Skilling

Currently, up to 29 percent of all current tasks are performed by machines, robots, Artificial Intelligence (AI), and algorithms. This percentage is going up and is expected to cross 42 percent by 2022, and exponentially grow faster to 52 percent by 2025. The new occupations that emerge will be responsible for creating a balance between human work and machine work. The rising demand for cognitive and social skills will set the premise for future employability.

Source: India Skills Report 2022

WHEN THE LIGHTS ARE OUT

Here's shedding light on lights-out machining, what must one consider while opting for it, and the benefits it brings to the table.



Source: Magic Wand Media

In today's rapidly changing metalworking industry, it is more important than ever to find ways for your shop to stay profitable. Now, the questions that arise include:

- How will you stay competitive with rising inflation?
- How are you planning to bridge the gap between lack of workers, competitive wages, and profitability?
- It's no secret that operating costs in the industry are rising. What's your plan for future success?
- For many operations, automation seems to be the most obvious answer. But what about lights-out machining?

There are a few things to consid-

er before turning the lights out.

What is 'Lights-Out' Machining?

Where a machining operation would normally have an operator overseeing the process, lights-out machining is a technique that requires minimal human input.

So, while a factory may have operators manning their stations throughout the day, lights-out machining allows automated processes to run without any direct oversight or control. For example, overnight with the lights out.

When to Invest in Lights-Out Machining?

Breaking into the world of lights-

out machining is no small undertaking. It requires a complete evaluation of one's enterprise, including tooling, materials, and which processes are suitable for unmanned operations.

It's not cheap, either—there is a significant technological investment in automation, so ensuring your ROI is of utmost importance. So, the question remains - when is it best to invest in lights-out manufacturing processes? It was once thought that this kind of automation was reserved for simple, loose tolerance parts made of easily machinable materials. That is no longer true. With the lack of talent over the past couple of years, automation technology has been thrust forward into Industry 4.0. Factories

Source: Triumph Tool Ltd

are increasingly finding robotic, software, and lights-out CNC machining solutions for tight tolerance, tough material components. There are a few factors involved in this decision, namely: Process stability; Machine capabilities (tool management, in-process metrology); Investment capital; and Time.

With the right combination of the above, you could be turning the lights out on any number of operations.

Considerations for Lights-Out Machining

As soon as you're ready to turn the lights out, there are a few things to consider to make the transition as efficient as possible.

Extending Tool Life and Back-up Tooling

Running a CNC machine without an operator means one thing - you need reliable tools with a long tool life. The first (and most apparent) reason is that you don't have someone standing nearby if something goes wrong. Hence, choosing quality tooling reduces the likelihood of crashes.

Secondly, because these operations would be running during

unmanned hours, tool life becomes critical. As a tool wears, parts become less accurate and the likelihood of error increases. With extended tool life, CNC machines will be able to run longer with the lights out, while also ensuring quality components. Thirdly, considerations need to be given to back-up or 'sister' tooling.

Initial Investment

Ensuring ROI, not surprisingly, is one of the biggest factors in determining whether lights-out manufacturing is feasible for your business.

It can be a large initial investment, but the industry is quickly evolving, as is our economy. For many, staying competitive means investing now to be scalable for the future. This could mean moving toward lights-out machining now, or simply standardizing your shop with something like 5th Axis workholding in preparation for future automation.

Job Prioritization

While we are now able to automate complex parts, automation tends to make a larger impact on smaller, simpler parts. Think of it this way - would

you rather pay your operators to watch a stable process? Or would you prefer them to be there while the risk of error is more likely?

With lights-out manufacturing, you can easily prioritize jobs to get the most out of your operation and increase the value of the time spent on the floor by your employees.

Productivity Versus Consistency

There is a constant push for productivity in manned manufacturing. But with automation, it's important to distinguish between productivity and consistency.

Which is better for lights-out machining? Consistency, hands down.

When a process is reliable and consistent, it can run longer unattended than pushing your tooling and machine to the limit to get as many parts out the door as possible. With lights-out machining, priorities need to shift to find a balance between productive manned hours and consistent results while the lights are out.

Material

When it comes to lights-out machining, as with any operation, the material matters.

While a factory may have operators manning their stations throughout the day, lights-out machining allows automated processes to run without any direct oversight or control.



Source: Magic Wand Media

Breaking into the world of lights-out machining is no small undertaking. It requires a complete evaluation of one's enterprise, including tooling, materials, and which processes are suitable for unmanned operations.



Source: Magic Wand Media

For example, the long stringy chips produced by softer metals can get caught up in the tooling and wreak havoc when left unattended, whereas tough metals create wear on tools that makes lights-out machining difficult over long periods.

There is a sweet spot in materials that tend to perform better during unmanned operations. For example, brass and 6061 aluminum alloys tend to be ideal. That said, remote monitoring and increasingly advanced technology are allowing us to turn the lights out on much more difficult-to-machine metals.

Automation Technology and Products

The saying goes, "it's not the tool, it's how you use it". In this case, however, it's both. Because we are removing the operator from the equation here (or at least part of it), you need tools that hold their own, on their own.

Benefits of Lights-Out Machining

Although it may seem intimidating to leave your machine unattended, there are many benefits to doing so. When the gap is bridged between technology, proper tooling, and appro-

priate machine equipment, you can expect:

Increased Productivity - If you haven't already, adding an extra unmanned shift to your shop has the power to significantly increase productivity. Imagine walking into your shop in the morning with the beginning stages of your project already completed, or seeing the simple time-wasting components that have your employees patiently waiting for completion already done. With lights-out machining, there can be a significant increase in the productivity of a shop that helps you get more parts out the door.

Scalability - With a shortage of workers, a skills gap that is quickly growing, and rising costs of goods, it is becoming increasingly difficult for manufacturers to stay competitive in the current climate. Lights-out manufacturing practices help businesses stay scalable by automating processes that would otherwise be a drain on resources.

Prioritization of Manpower - There are some components that just need a human touch; there's no doubt about that. But, with unattended machining, you can prioritize when and where to direct your man-

power. For example, time-consuming components that have operators waiting on long cycle times could be shifted to lights-out operations if stable.

There is much to consider with unattended machining, but working with the right distributor ensures an easier transition. As your Machining Solutions Partner, Triumph Tool Ltd helps you compete by:

- Offering sound technical advice that helps you choose the right tooling for the job;
- Providing unparalleled customer service, so you are never left without answers;
- Adding insight on how you can save time, tool life, and money;
- Engaging the right manufacturer partners; and
- Connecting you with innovative solutions that help you get the job done faster, better, and with more money in your pocket.

Are you considering adding lights-out operations to your facility? Or improving your existing ones? Triumph can help with high-performance tooling and some of the best tech partners on the market, so you can run lights out without losing sleep. 



HANN KUEN MACHINERY

HARDY



TAIWAN EXCELLENCE
2017

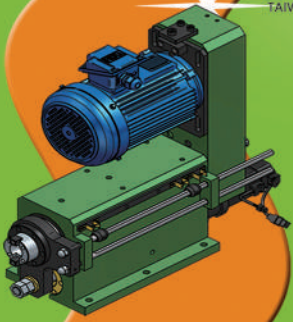

Servo Type Drilling / Tapping Spindle Head Unit

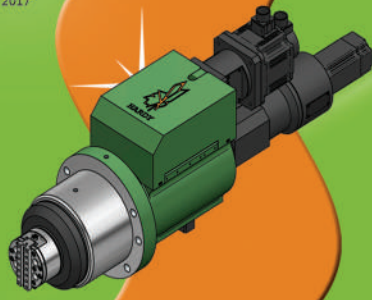

Built-in Motor Facing Head Unit - Flange Type

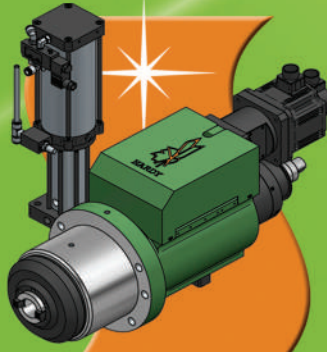

Built-in Motor Drilling/Tapping Spindle with ATC and Center Coolant



TAIWAN EXCELLENCE
2020



Built-in Motor Spindle Unit



TAIWAN EXCELLENCE
2020

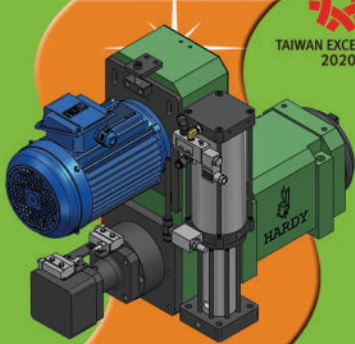

Boring/Milling Head Unit with ATC

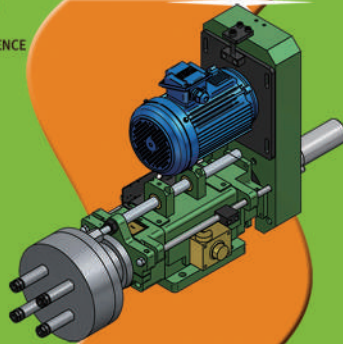

Multi-Spindle Head

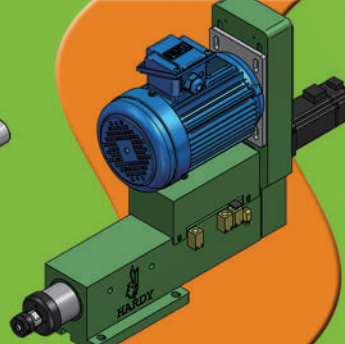

Servo Type Drilling / Tapping Spindle Head

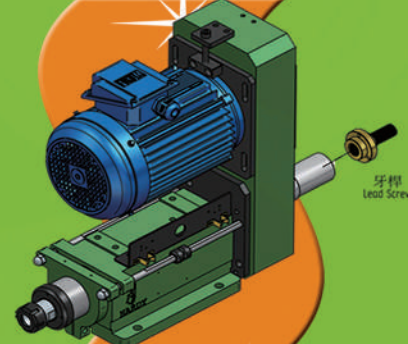

Tapping Spindle Head

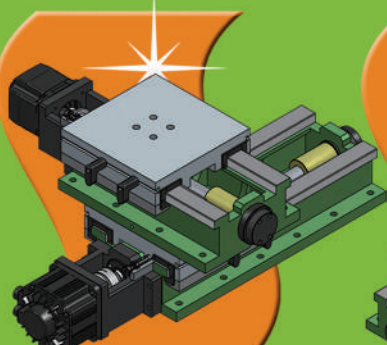

XY Servo Hardness Slide Unit

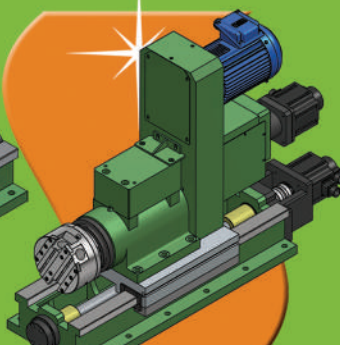

Servo Facing Head + Servo Ball Screw Slide Unit

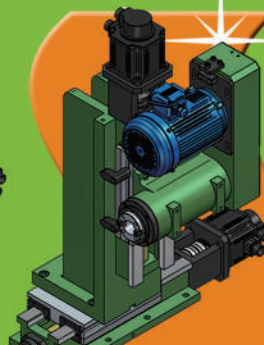

XYZ Servo Slide Table + Milling Head

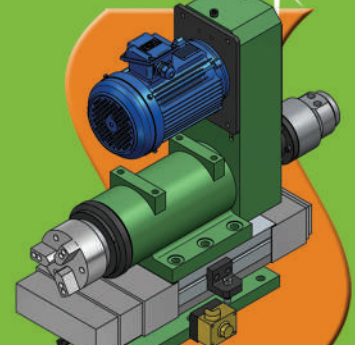

3-Jaw Chuck Spindle + Slide Unit



HARDY

HANN KUEN MACHINERY & HARDWARE CO., LTD.
NO. 22, Liou Shun Rd., East District, Taichung City 401, Taiwan
TEL: +886-4-2486-0602 FAX: +886-4-2486-0605
E-mail: hann.kuen@hardy.com.tw
https://www.hardy-tw.com Skype: hann.kuen



TOWARDS AN ELECTRIC FUTURE

For India to become a manufacturing hub for EV Cells, we need a long-term strategic roadmap.



Source: Magic Wand Media

As experts commented, "Transportation is transforming, and we need to get ready," little did policy-makers, entrepreneurs, and OEM suppliers in India know how electric vehicles were to change the entire outlook for the Automobile industry in the next decade.

As the Indian Government has placed itself firmly in the driving seat to usher in the revolution of Electric Vehicles (EV) by planning to become a 100 percent 'Electric Vehicle Nation' by 2030, it is necessary to look objectively into manufacturing costs and the viability of the target. As EV cells constitute 60 to 70 percent of the total cost of EVs, it is pertinent that the Government sets a clear roadmap for manufacturing lithium-ion (Li-ion) batteries.

Importing the batteries for EVs definitely makes the product costlier in the Indian market compared to conventional internal combustion engine (ICE) vehicles, or what we call petrol vehicles. However, manufacturing these cells in India would be cost-effective only when it catches up to the scale in the other Li-ion cell manufacturing countries. And here comes the catch - despite multiple policy and strategic interventions by the Government, India suffers from structural issues that it has to address before being able to become a production hub for Li-ion cells.

The structural roadblocks

Firstly, we have started late. The Government's initial plans, way back in 2015 when the Faster Adoption and Manufac-

turing of (Hybrid &) Electric Vehicles (FAME) India Scheme was launched, failed to address the Manufacturing industry related to EV components. Instead, the plan incentivized and concentrated on EV manufacturing and adoption by addressing the issue of EV charging stations. As a result, Phase II of the scheme, which was supposed to end in March this year, has now been extended until 2024.

Secondly, while policies have been introduced for setting up manufacturing units, there is nothing on the expenditure side for research and design. We must recognize that capital investment for cell manufacturing facilities is huge. A typical Gigafactory will need ₹1,100 to 1,200 crore of investment to start. And given the nascent stage of battery man-

SAURABH PATAWARI
Founder
Natural Battery
Technologies



ufacturing know-how, the gestation period will be the next decade – even with technology transfer and ensured investment from big players.

Thirdly, access to raw materials for manufacturing Li-ion batteries is a raging issue. As a study by European Commission 2020 showed, except for manganese and graphite, all the other raw materials are hardly available in India. We will have to keep importing from Australia, China, Brazil, Africa, and Canada for raw materials like bauxite, cobalt, manganese, and natural graphite, apart from lithium. In February 2020, Union Minister Harsh Vardhan informed the Lok Sabha that India imported 450.3 million Li-ion batteries in the April-November period of the financial year 2019-20, valued at US\$929.26 million (over ₹7,200 crore). As per the data by the Ministry of Road Transport & Highways (MoRTH), the number of EVs registered in 2021-22 has grown by 218 percent from 1,34,853 in 2020-21 to 4,29,301 in 2021-22. We have to see how much the economics of scale for import cost of raw materials versus manufacturing Li-ion batteries and the investment is required to make the first Giga-factory operational.

How can we address it?

However, none of the problems is insurmountable if the stakeholders involved in making EVs a reality in India are ready to join hands, plan long-term, and are dedicated to the cause.

The Government, in 2021, introduced a ₹18,100 crore Production Linked Incentive (PLI) scheme for Advanced Chemistry Cell (ACC) battery storage, with a total manufacturing capacity of 50 GigaWatt Hour (GWh). Subsequently, four players, i.e., Reliance New Energy Solar, Ola Electric, Hyundai Global Motors, and Rajesh

Exports, were shortlisted. As per a 2018 research report by the Center for Study of Science, Technology and Policy (CSTEP), a plant of this scale is estimated to cost around ₹30,000 crore (US\$4.6 billion) with a timeline of about three years to become operational.

By 2030, the market for electric vehicle power packs is expected to reach US\$300 billion, with a large secondary market of more than 2.5 million e-rickshaws and 4,00,000 lead-acid battery-powered two-wheelers now on the road. India would require a minimum of 10 GWh of Li-ion cells by 2022, according to Government projections. By 2025, it will be around 60 GWh, and by 2030, it will be around 120 GWh.

Thus, even when the project becomes operational, EV manufacturing will need a lot of handholding and support to become viable. Most importantly, it will take a lot of patience to see the EV market mature with sustainable domestic OEM supplies.

A sustainable future

According to a study by CEEW Centre for Energy Finance (CEEW-CEF), an initiative of the think tank the Council on Energy, Environment, and Water (CEEW), the cumulative EV sales in all vehicle segments could cross over 100 million units by FY30, 200 times its current market size, as by the end of March 2020, the total number of registered EVs in India stood at only half a million. The study also pointed out that to realize the 2030 ambition of India, the country would need an estimated annual battery capacity of 158 GWh by FY30, thereby presenting a massive market opportunity for domestic manufacturers. Also, the EV market will be worth

around ₹14.42 lakh crore, with a need for cumulative investment worth around ₹12.50 lakh crore for the same.

The planning, investment, and long-term roadmap are worthwhile for the sustainable future that an EV-led transport system could create. As Carlos Ghosn, the ex-Nissan CEO, mentioned, "Electric Cars are not going to take the market by storm, but they are going to be a gradual improvement." In the same way, the Indian market cannot hurry to make EVs a reality.

Along with consistent policy support, availability, and affordability of capital for OEMs, battery manufacturers, charge point operators, and end consumers would be vital in determining the pace, efficiency, and cost of India's transition in the transportation industry.

Once underway, the indigenous batteries can ensure a sustained supply to the EVs, irrespective of global conflicts. The batteries will be more suited to Indian temperatures and geographical disparities through designs and research. While it is accepted that EVs will benefit the environment, in the long run, with the right technology, over 90 percent of Li-ion batteries can be extracted and reused, thus leading to a recycling of the e-waste being generated.

Most importantly, India is projected to save over ₹1 lakh crore annually in crude oil imports with increased EV penetration, as per the CEEW report of 2020. A sustainable future will need planning and a detailed roadmap to see the positive results that we are planning for. India is roughly late by 15 years in the research and development of EVs and related OEM technology. However, persistence and clarity, in this case, will surely pave the way for a better future. 

Along with consistent policy support, availability, and affordability of capital for OEMs, battery manufacturers, charge point operators, and end consumers would be vital in determining the pace, efficiency, and cost of India's transition in the transportation industry.

QUALITY CONTROL MATTERS

A high-precision shop producing medical and aerospace parts was about to lose its quality management system. When it found a replacement, it also found a partner that helped the shop bring a new level of automation to its inspection process.



Source: Magic Wand Media

There are practical reasons why machine shops might shy away from highly complex parts. Small, multifaceted medical implants for the spine or jet engine components such as fuel injection nozzles might feature hundreds of dimensions per part, with tolerance requirements that routinely fall within two ten-thousandths (0.0002) of an inch. Even when perfectly machined, the parts are worthless without the documentation required for compliance with medical and aerospace standards, such as ISO 13485 or AS 9100.

When complex parts come with stringent inspection requirements, the quality control process begins with three core questions:

- Which part dimensions require inspection, and at what point in the process?
- What equipment should be used to check those dimensions?
- At what frequency will those dimensions be checked?

For mid- to high-volume shops, the amount of data required to answer these questions can become so overwhelming that shops turn to multiple software platforms to perform individual tasks. One software

for ballooning, one for first article inspections (FAI), one for in-process inspections, and so on. Considering the sheer volume of data, trying to fine-tune different software platforms to communicate effectively with one another becomes a nearly impossible, thankless task. Cross-channel data traffic gums up the network. Operators trying to input inspection data are greeted by spinning wheels of death. The keepers of tribal knowledge about each software system grow fewer in number. As for training new employees on the system? Good luck. This is exactly the situation

BRENT DONALDSON
Executive Editor
Modern Machine Shop
bdonaldson@
mmsonline.com





Source: Photos by Brent Donaldson, with screen captures provided by 1Factory

John Loscheider, CMM Programmer, Ultra Machining Company, oversees an automated CMM and multi-axis robot. The inspection data from this CMM is uploaded in real time to the shop floor, allowing machine operators to see whether the parts remain within tolerance requirements.

that a high-precision shop near Minneapolis called Ultra Machining Company (UMC) found itself in just two years ago. The business had accelerated, but so had the burden of managing stringent quality control standards on highly complex parts. By 2019, UMC was collecting a million points of part inspection data per month, then segmenting it off into five separate quality management platforms. One of those platforms was designed and built by UMC in partnership with its vendor, in the hope of eventually marketing the software and selling it to customers. But the software became so highly customized for UMC that, whether related to its customization or not, the vendor decided to exit the product category. The vendor notified UMC that, after a six-month phase-out period, it would no longer support it. Sarah Sundine, Director, Project Management, UMC, remembers the day the news dropped – during a production crunch when UMC was actively processing more than 1,000 parts. “We were like, oh my gosh, if

you shut down our quality software, we can't run,” she recalls.

A sleepless month of nonstop work

The immediate response from Sundine and her team was to write a request for quote (RFQ) that included more than 150 technical requirements, which UMC then blasted out to quality management software companies around the globe. After a weeks-long vetting pro-

cess, UMC had all but signed a contract with another quality management provider when a colleague of Sundine began researching one of the lesser-known bidders on the RFQ. That research led to Nipun Girotra, CEO and Co-founder of a company based in San Jose, California called 1Factory.

“It was the most detailed RFQ I've ever seen,” Girotra says. But a quick demo of 1Factory by Girotra and his business partner, CTO and Co-founder Oleg Nickolayev, was impressive enough to convince UMC to purchase a 30-day pilot program.

At the end of the trial run, nearly everyone at UMC who interacted with 1Factory, from the machinists to the quality engineers to the inspection lab workers, lobbied hard for the company to adopt it, Sundine says. So, as the clock ticked down toward pulling the plug on UMC's existing quality control software—and as COVID-19 began sweeping the globe—Sundine, Girotra, Nickolayev, and several members of UMC's team embarked on a sleepless month of nonstop work to integrate 1Factory into

UMC is a family-owned machine shop that not only produces complex parts routinely but also machines a full spectrum of challenging materials, such as Hastelloy, Inconel, Titanium, and Cobalt alloys.



Source: Modern Machine Shop

UMC, which recently expanded to more than 140,000 sq ft of shopfloor space, relies on its quality control system that features real-time availability of measurement and inspection data.

UMC's systems.

Let's learn how the two companies pushed the envelope of automated quality control data in a machine shop.

Ultra Machining Company

I first met Nipun Girotra and Oleg Nickolayev at 1Factory's booth at Westec in late 2021. Displayed on a large screen behind the two men was a print drawing of a complex part that had been auto-ballooned by their software. "There is plenty of quality control software that auto-balloon prints," Girotra said, before launching into a dizzying array of features built into the platform.

"By the way," he asked at the end of the visit, "have you ever heard of a shop near Minneapolis called UMC? It might be the most impressive machine shop I have ever seen."

Established in 1968 near Minneapolis, UMC is a family-owned machine shop that not only produces complex parts routinely but also machines a full spectrum of challenging materials, such as Hastelloy, Inconel, Titanium, and Cobalt alloys. UMC's 140,000-sq ft shop floor is organized into separate operation-



Like most workstations on UMC's shop floor, Machinist Gerrit Fonkert's station features several measurement tools and a computer where he processes each part's inspection data in real time with 1Factory.

Source: Modern Machine Shop

As the control plan is created in 1Factory, UMC quality engineers can manually define or let the software auto-generate sampling rules for part inspections.

al departments for mill-turn, Swiss, EDM, turning, milling, prototyping, and inspection. As a company that primarily serves highly regulated industries, including Medical, Aerospace, and Defense, the UMC's inspection lab is a central hub of activity. The lab boasts eight vision machines and more than 20 coordinate measuring machines (CMMs), some of which are serviced by pallet changers and multi-axis robots.

By the time I arrived at UMC in March, the company had fully integrated 1Factory into its

operations. On the shop floor, every workstation featured a desktop computer with 1Factory displayed on the monitor. Everyone was tuned to the same channel.

The quality control process at UMC begins like this: An engineer uploads the customer's print, typically from a PDF drawing, and 1Factory auto-balloons the drawing and assigns numbers to the part's features, including radiuses, diameters, positions, geometric dimensioning and tolerancing (GD&T) data, and any text instructions contained in the margins. Let's say that balloon 1 is a linear dimension located in zone f5 with a mix/max value of 0.843–0.847 in. The software extracts this information and populates it into an auto-generated quality control plan. Attempting this process manually (still a reality for many shops) means ballooning one feature at a time and individually notating all the values required for the report. Mistakes discovered down the line of a manual process often mean starting over from scratch.

As the control plan is created in 1Factory, UMC quality engi-



UMC Machinist Jeremy Desmet views the inspection history of a part using 1Factory's run chart.

Source: Modern Machine Shop

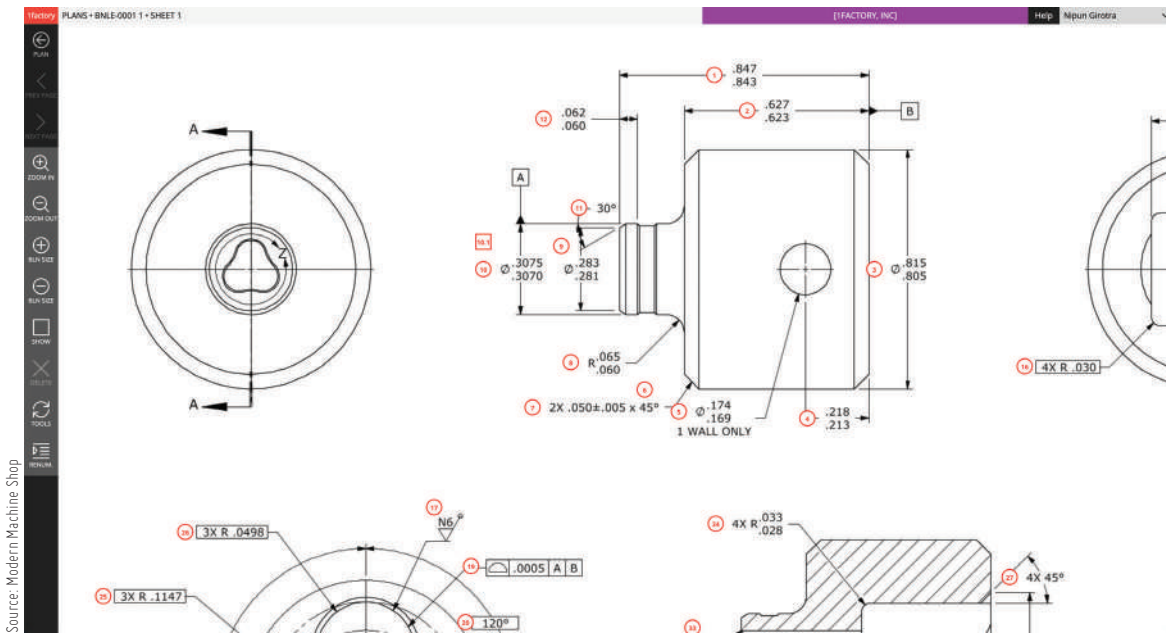

The first step in UMC's quality management process for each part is to auto-balloon the print, like above, then export the data into a quality control plan.

neers can manually define or let the software auto-generate sampling rules for part inspections. For instance, a critical feature for a highly regulated industry might require inspection of every tenth part by a laser micrometer, while a non-critical feature may require inspection of every hundredth part by a digital caliper. The software also ties every part feature to the specific tool or CMM required to inspect it. As parts come off the machine, the control plan lets UMC's machine operators know which features require measurement checks at their workstation and which measurement tool to use for the inspection. If an operator on the shop floor

is looking at the control plan and needs to find the location of a specific feature on the part, rather than searching through a complex print drawing to find one feature among dozens or hundreds, a click of the mouse on the feature number zeroes in on the precise location of the feature on the print. Capabilities like this were part of the solution that UMC sought in a new quality control system. But they weren't necessarily unique in the marketplace. Several of the 12 different vendors that UMC evaluated after its RFQ offered functionalities like auto-ballooning, data capture, and control plan processes. What put 1Factory over the top, Sundine says, were two

specific qualities: its ease-of-use and the promise of integrating in-process inspection data, uploaded in real time, from all 28 of UMC's CMMs. Why just a promise? Because until Sundine's team asked for this capability, 1Factory didn't have it. It took UMC to help them get there.

“OK, prove it.”
 This was the gauntlet thrown down by UMC to 1Factory – a challenge to automate the data output of nearly 30 CMMs straight into 1Factory in real time. “And we built it,” Girotra says. “And by the way, we built it within that first month of the pilot.” This capability means that every data point from every touch

As parts come off the machine, the control plan lets UMC's machine operators know which features require measurement checks at their workstation and which measurement tool to use for the inspection.

No.	Sheet/Zone	Specification	Places	Type [all]	Insp. Method [all]	Sampling [all]	Key? [all]	Label [all]	Dim. [all]	Oper. [all]	Ppk	Cpk	Min	Max	Progress [all]	
8	1: D1	± 0.208 — 0.212 in	1	NUM	Drop Indicator	100% [35]	✓	Process ...	STD	50	3.02	4.35	0.2090	0.2102		
10	1: C1	0.001 in	1	NUM	Indicator	1 in 10 [4]	○	Process ...	STD	50	1.04	0.79	0.0001	0.0005		
104	2: C2	∅ 1.273 — 1.277 in	1	NUM	Borematic	1 in 10 [4]	○	Process ...	MFG[3]	30	3.74	2.91	1.2749	1.2752		
105	2: C2	∅ 0.010 / A / B / in	1	NUM	Indicator	1 in 10 [4]	○		STD	30	29.24	37.24	0.0000	0.0002		
108	2: G2	± 0.217 — 0.221 in	1	NUM	Drop Indicator	1 in 10 [4]	○		STD	30	2.01	2.26	0.2190	0.2195		
109	2: F4	0.001 in	1	NUM	Indicator	1 in 10 [4]	○		STD	30	2.07	1.76	0.0002	0.0004		
110	2: F3	∅ 1.610 — 1.614 in	1	NUM	Blade Micrometer	1 in 10 [4]	○	Process ...	MFG[13]	30	5.61	4.76	1.6118	1.6120		
111	2: F3	∅ 0.001 / A / in	1	NUM	Indicator	1 in 10 [4]	○		MFG	30	4.26	3.13	0.0001	0.0002		
114	2: F2	± 0.063 — 0.067 in	1	NUM	Drop Indicator	100% [35]	✓	Process ...	MFG[7]	30	8.90	11.40	0.0645	0.0648		

The inspection summary screen in 1Factory shows, among other data, the inspection method and the sampling rate for each part feature.

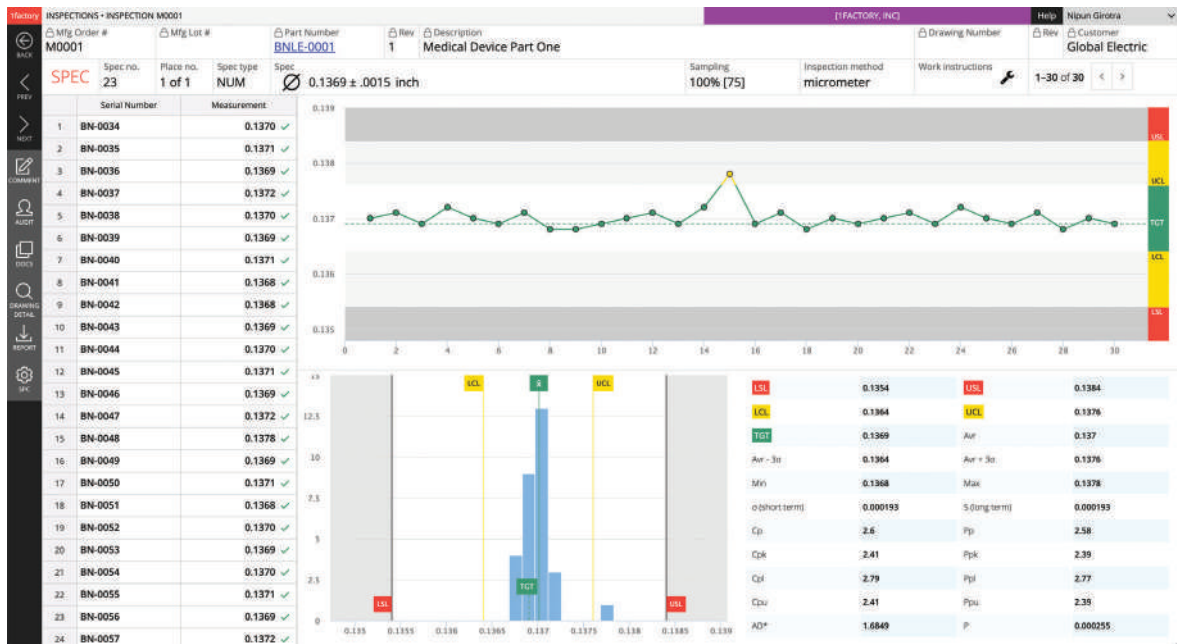

Source: Modern Machine Shop

If a part fails inspection, 1Factory automates the non-conformance report process by uploading the part number, the out-of-tolerance feature, the part description, the operator assigned to the inspection, and the day and time of the part's production.

1Factory's run chart, histogram, and statistical process control data show feature-level tracking for each part. In this example, only one measurement of one feature fell into the yellow zone, indicating that the feature measured within 25% of the required tolerance.

of a CMM probe or scan of a vision machine is visible almost instantly to every machinist at every workstation on the shop floor. Once UMC's inspection data is in 1Factory, the software analyzes the data and creates a run chart and histogram that show which part features present the highest risk of failure. This real-time feedback loop means that 1Factory is integrating UMC's inspection points—not only from the CMMs but

also from manually input data—and then handing over statistical process control (SPC) to the machinist. The visual data lets the machinist know that adjustments to the machining process are needed to bring the measurements back in line. If a part fails inspection, 1Factory automates the non-conformance report process by uploading the part number, the out-of-tolerance feature, the part description, the operator assigned to the

inspection, and the day and time of the part's production. The report also identifies which gage or CMM was used for inspection and can identify all prior inspections performed with that gage. On top of that, the software tracks calibration schedules for all measurement equipment—which at UMC includes more than 10,000 hand gages—and displays a red flag if an operator attempts to use a gage that requires calibration.



Source: Modern Machine Shop

Sarah Sundine, Director, Project Management, UMC in the company's CMM lab. Sundine helped lead a transition from the company's use of five different quality management software platforms to full integration into 1Factory.

MACHINE TOOLS GALORE

The 31st edition of the specialized exhibition on machine tools Japan International Machine Tool Fair (JIMTOF) is to be held on November 08-13, 2022, at Tokyo Big Sight. The organizers have announced its Exhibition Scale and Exhibitors' List.

Japan Machine Tool Builders' Association and Tokyo Big Sight Inc, the organizers of the show, have announced the exhibition scale, number of exhibitors, and site map by product category of JIMTOF 2022.

JIMTOF is regarded as one of the world's largest international technology exhibitions, introducing machine tools and their associated machinery as a comprehensive display for manufacturing companies and institutions. It also introduces the most recent and cutting-edge machine tool technologies and products. The event has been held biennially since 1962 and will celebrate its 60th anniversary in 2022.

The trade fair aims to contribute to industry development and trade promotion through increased international transactions and technical exchanges of machine tools and related equipment. This year's event is themed 'Open the door to the future -

Meet the technologies moving the world forward'.

A worthy platform

JIMTOF 2022 will be using all the venues of Tokyo Big Sight, including the South Hall, which opened in 2019. As in JIMTOF 2018, all the exhibitors' booths

place in the new South Hall. The indoor exhibition space is 118,540 sq mt.

Exhibition scale

The show will host 861 exhibitors and have a record number of 5,610 booths in total, which

excludes co-exhibitors and represented companies. It will feature 788 domestic exhibitors (5,360 booths) and 73 overseas exhibitors (250 booths). The exhibition scale of the Additive Manufacturing Area includes 53 exhibitors in 166 booths. At JIMTOF 2022, products from a variety of industries will be exhibited, and the latest information on products and technologies will be shared

with the visitors.

JIMTOF has an established reputation as an exhibition where visitors can obtain the latest information on a wide range of products used in the manufacturing industry. 



JIMTOF 2022

The 31st JAPAN INTERNATIONAL MACHINE TOOL FAIR

Nov.8 (Tue.) -Nov.13 (Sun.), 2022

in JIMTOF 2022, including both domestic and overseas exhibitors, will be placed into categories of the products being exhibited. The Special Event, under the theme 'Additive Manufacturing Area in JIMTOF 2022', will take

Source: JIMTOF



Source: Valgro India Ltd

EXCELLING IN SURFACE MATTERS

Established in 1996, Valgro India has been developing reliable specialty products and machines for the metalworking industry, ever since and has earned the reputation of being a total surface treatment solution provider. Read on to know about its origins, the journey so far, and the plans ahead.

Valgro India Ltd, one of Asia's largest deburring and metal finishing abrasive brushing machine manufacturers, has consistently set standards in product quality with ISO 9001-2018 quality regulation from TUV Sud Germany. With almost 25 years of excelling in the field, the company has become a well-known name in the metalworking sector due to its commitment to satisfying its customers' ever-changing needs and developing technologically advanced products. "Our primary area of focus is to provide a high-resolution value finish with edge round-

ing of machine compounds, which is in great demand from high-precision engineering industries. This can be accomplished without any material deformations or deviations in the dimensions," shares Dr Arvind Patel, Founder & CEO, Valgro India Ltd. With the present Group turnover being ₹15 crore, the company's target for the next fiscal year is ₹25 crore.

From humble beginnings

Dr Patel talks of his meteoric rise and the journey that led to it. The family was in the textile business when it met with a fi-

nancial crisis in the early 1990s during a recession in the global textile industry. A large number of textile mills collapsed due to rapid advances in technology and inventiveness.

This was when he established a modest trading enterprise to supply industrial products to industrial businesses. In 2005, he launched a limited liability firm called Valgro Engineers Pvt Ltd, imported abrasive products from Europe, and transported them to Indian factories by ship. "The year 2009 saw the beginning of our in-house manufacturing of surface conditioning abrasives

POONAM PEDNEKAR
Chief Copy Editor
Magic Wand Media Inc
poonam.pednekar@
magicwandmedia.in





that were sold under the brand name, Valgro,” he informs.

“In 2015, we set up a new company called Valgro India Ltd—Machine Building Division for the growing abrasive business. The company makes high-precision machines for finishing metal that meet German standards but are made for Indian industries. They are priced so that midsize businesses can easily afford them. Today, we have a well-known brand of Metal Surface conditioning abrasive brushes and wheels, as well as

machines that finish metal. We are proud of the pace at which we are growing and grateful to our customers, whom we always put first,” he adds.

The company has successfully installed its polishing machines in 16 countries, including the USA, Canada, Russia, the Middle East, Southeast Asia, Bangkok, Vietnam, and Indonesia.

Innovation and customer-centricity

Valgro India is among the country’s top five quality non-woven abrasive producers. Dr Patel elaborates on how the company has achieved this status. “Innovation is important to the success of our company. We are quick to adopt the latest developments in technology and incorporate them into our machinery, processes, and services. This consistent innovation has generated trust in our customers,” he reveals.

Another important focus, he says, is the company’s steadfast support for its clients, which has been a tremendous help in its growth. “We have cultivated a customer-centric approach to brand building. Our marketing strategy is to help our customers and guide them through the right process. Today, social media is powerful, with tools to reach the right customer. Our team is always engaged in finding the right customers and is



Source: Valgro India Ltd

“Innovation is important to the success of our company. We are quick to adopt the latest developments in technology and incorporate them into our machinery, processes, and services. This consistent innovation has generated trust in our customers.”

Dr Arvind Patel
Founder & CEO
Valgro India Ltd

involved with them to understand their challenges, build a comfortable environment and develop trust in them. They are with the clients to help them increase productivity, reduce rejection, and rework during their production setup,” he adds. “This has resulted in stronger customer connections, higher retention rates, and more customer referrals. By providing consumers with a positive and memorable experience, our company differentiates itself from the competition and gets and retains more customers,” he adds further.

Valgro India has successfully installed its polishing machines in 16 countries, including the USA, Canada, Russia, the Middle East, Southeast Asia, Bangkok, Vietnam, and Indonesia.

PLASMA GAS CUT PARTS – SLAG & DROSS REMOVAL



Source: Valgro India Ltd

COPPER BUS BAR POLISHING MACHINE



Source: Valgro India Ltd

As raw material prices rise, so does the demand for reliable deburring and edge finishing operations. Deburring is still a significant finishing technique used in the industrial industry.

Relevant to all sectors

Since deburring and finishing are value-added services that are required in all sectors, Valgro India is engaged with different segments, such as Auto, Aircraft, Precise Engineering, Shipbuilding, Architectural and Construction fabrication, Kitchen and Restaurant equipment, and so on. Dairy Equipment, Food Process Machinery, Pharmaceutical Processing Machinery, Packaging Machinery, and Beverage Equipment Manufacturer Construction of a Processing Plant, Escalator, Elevators, Doors, Public Transportation System, Metro, and Railways are other sectors that the company supplies its offerings to.

“Sheet metal processing after cutting and punching is our most profitable market,” informs Dr Patel.

As raw material prices rise, so does the demand for reliable deburring and edge finishing operations. Deburring is still a significant finishing technique used in the industrial industry. Trimming and polishing are inherent in the deburring process and are used in the production of sprockets, gears, camshafts, and other parts. It is widely utilized in a wide range of industrial industries, including Auto,

“As the demand in the market continues to rise, businesses are finding it increasingly difficult to find qualified workers and meet their production deadlines. The technologically-advanced products that Valgro India provides help to lessen their reliance on manual labor, boost their production, and cut down on the instances of rework and rejection.”

Dr Arvind Patel
Founder & CEO
Valgro India Ltd

Aircraft, Computer Components, Toy Production, and many more. “Deburring and edge finishing are used in each of these domains to eliminate rough edges, reduce cost and performance, and improve safety and aesthetics. Deburring is an essential and expected use in the Manufacturing industry worldwide. It will continue to be a key component in the creation of high-quality items throughout the world as the global economy grows more integrated,” he says.

Accomplishing targets

“Investing in competent, highly qualified technical employees, modern machinery and infrastructure, and delivering on time are some of the most important things that contrib-

ute to our company’s success,” shares Dr Patel.

This explains how Valgro India’s goal of installing over 100 pieces of machinery in the fiscal year 2021-22 was smoothly accomplished. “The entire Valgro team worked diligently towards the goal. We sold more than 125 machines in the period,” he proudly says.

Plans ahead

Dr Patel says he has complete faith in the company’s products and technology, which can be made accessible at affordable prices. “As the demand in the market continues to rise, businesses are finding it increasingly difficult to find qualified workers and meet their production deadlines. The technologically-advanced products that Valgro India provides help to lessen their reliance on manual labor, boost their production, and cut down on instances of rework and rejection,” he says. “We anticipate that our machinery will assist all industries involved in metal processing in meeting the demand for metal finishing. With the implementation of our strategic plan, Valgro will establish itself as a market leader in the metal finishing sector by 2025,” concludes Dr Patel on this optimistic note. 



Source: Valgro India Ltd

THE PERFECT ROBOT

Automation Technology for Robotics (ATRO) from Beckhoff Automation is a compact multi-axis system, which is modular, flexible, integrated, and ideal for every application.



With ATRO, a robot solution can be adapted precisely to the task with any number of axes and is freely scalable, modifiable, and expandable.

Beckhoff has presented a new concept for robotics applications with ATRO, a modular system from which the right robot kinematics can be put together extremely flexibly for any application. A highlight of the system is the internal media feed for data, power, and fluids. This has been implemented in such a way that all axes are designed to rotate endlessly. With ATRO, users can create almost any robot design for their application from the modules provided – from a simple 1-axis rotary indexing table application

and delta kinematics, through to multi-axis articulated robots. Beckhoff's holistic perspective is decisive for simple commissioning and handling, because only the direct integration of the robot system into PC-based control enables a truly optimized complete solution for the machine or plant. This reduces the number of controls needed on one industrial PC, even with multiple robots. ATRO kinematics is made up of active joints—the motor modules. The motor modules are available in different designs: straight modules in I-shape or angled modules

in L-shape, which are designed in five power sizes. Each motor module forms a complete drive system for one axis of the robot. The only external components required are a power supply and a control, which significantly reduces the space required in the control cabinet. In addition to the active modules, there are connection modules without their own drive:

- base modules as a base including the media feed;
- link modules with I, L, and Y-shapes for implementing individual robot configurations; and

- system modules that can be used to integrate additional functions such as a camera.

Advantages through internal media feed

All modules are interconnected via the ATRO interface, which guarantees a rigid connection and also passes through the media that is fed in. Data, power, and fluids (compressed air, vacuum, or water) are thus guided internally through the modules in the ATRO kinematics. Conventional robotic solutions, on the other hand, route them externally and are, therefore, limited in rotation and use of the workspace. This limitation is completely eliminated with the Beckhoff solution – each axis can be rotated endlessly, which enables better Cartesian accessibility as well as short positioning paths. Furthermore, interfering contours, e.g., due to externally located cables and, especially in the case of cobots, interfering torques, are avoided by means of external media feed. In addition, the media are supplied again for a customer application via the ATRO interfaces, and almost any robotic tool can be easily integrated, such as sophisticated gripper systems.

System integration without limits

With ATRO, Beckhoff offers a highly flexible robot system that has all essential machine functionalities due to its deep integration into the TwinCAT automation software. These include, for example, image processing for sophisticated applications (bin picking), improvement of motion performance through machine learning, or direct cloud integration for analysis and maintenance. The use of open interfaces and universal standards enables plug-and-play of the created robot configuration as well as simple engineering. This variety of functions concentrated in one control minimizes hardware costs and also ensures maximum synchronization of all components as well as low delays in data communication. This also includes the direct combination with intelligent transport solutions such as XTS and XPlanar. Other areas such as communication, functional safety, and the actual application can be created with little effort. This not only enables the configuration of an extremely powerful overall solution with maximized system output, but also a previously unattainable reduction in machine footprint. 

A highlight of the system is the internal media feed for data, power, and fluids. This has been implemented in such a way that all axes are designed to rotate endlessly.



MODERN MANUFACTURING INDIA
WWW.MMINDIA.CO.IN

The Official Magazine of



Indian Machine Tool Manufacturers' Association

In Association with



MMI: Committed to bring the Best of the Manufacturing sector



Where Does The Print Industry Go From Here?

Around 70-80% decision makers of B2B Manufacturing Sector still prefer Print over Digital.

- Harvard Business Review

Contact: MURALI SUNDARAM
E: murali.sundaram@magicwandmedia.in
M: +91 9740048390

COMPETING ON A GLOBAL SCALE

Castle Precision Engineering has been using CGTech's VERICUT CNC simulation software for many years, protecting high-value customer components as well as its own advanced machine tools. The company has now embraced the efficiency and productivity gains offered by the Force module of the software.



Castle Precision Production Cell

Source: CGTech

While Castle supports a number of advanced industry sectors, such as Medical Devices and Power Generation, the majority – around 90 percent – of its circa £20m annual turnover comes from the Aerospace and Defence sectors. To cater to the diverse needs of its customer base, there are three focused sub-divisions that encompass what the business has to offer: Rotatives, Prismatic, and Toolroom.

Roy Yuile, Manufacturing Engineering Manager, Castle Precision Engineering, explains: “Rotatives and Prismatic are

the two core areas of our production business, and both require extremely high levels of precision and machining expertise. Over the years, we’ve carved out a niche for ourselves in manufacturing critical rotating parts for the aero engine market—failure of these parts can bring an airplane out of the sky, so our OEM customers are not only trusting us with their reputations but also with the safety of the pilots and passengers whose flights they power. We also manufacture a wide range of complex prismatic products to very exacting tolerances for applications such as

defence optronics and hydraulic actuation systems for control surfaces and landing gear.” Prismatic parts are typically machined from relatively straightforward materials, primarily aluminum alloys, along with some steel and titanium. However, rotating aero-engine components usually involve more exotic and difficult-to-machine materials, including titanium and nickel-based super alloys, where forgings valued up to US\$100,000 for a single workpiece are not uncommon. With a population of around 60 CNC machine tools representing the latest multi-axis manufactur-

Source: CGTech

With VERICUT an established part of Castle's business for the past 12 years, the software has proven its ability to protect the company as well as being a key improvement tool for its manufacturing processes.

ing technology from DMG Mori, Makino, Doosan, and Grob, the shopfloor at Castle is a lesson in housekeeping and efficient organization for all to see. Looking more like a cleanroom than a workshop, it highlights what a class-leading aerospace supplier should strive to achieve and creates an environment that nurtures professional behavior at every level.

VERICUT, a safety net

Protecting this advanced manufacturing capability is VERICUT CNC simulation software. Yuile says: "CAD is at the front end of our engineering workflow - we either import a 3D model supplied by the customer or draw one up from a 2D definition and break this down into the various stages of manufacture, from material supply to finished part. These stage models and their accompanying fixtures or workholding devices are transferred to CAM, where we build tools, generate toolpaths, post NC code, and then port the whole job straight into VERICUT using their CAM interface."

He continues: "VERICUT has been an established part of our workflow for over a decade - nothing goes out to a machine without first going through VERICUT, and that is across the board. It is an essential safety net, not just for the product but also for our machines and personnel. We have some programs in our factory that have been around for 10 or 20 years, alongside jobs that are fresh out of CAM. We use VERICUT to simulate any new or modified code before it goes out to a machine. We have a digital twin for almost every machine tool, and because VERICUT reads the same G-code as the machine controller, it's completely CAM-agnostic and can simulate code from any source." Very often, process improve-

Requirement

Castle Precision Engineering was on the lookout for a Physics-based optimization software for it to be competitive on a global scale.

Solution

The company opted for CGTech's VERICUT Force, which offered immense benefits, including the ability to identify where chip load spikes occurred and slow the feed rate to level them out, reducing tool wear and improving both tool life and process stability. It also helped Castle reduce consumables spend.

ments are made using VERICUT because the software offers the opportunity to prove edits in a virtual environment. "We don't edit at the machine console because of the risk involved," Yuile adds, "If you mess up, you have no safety net. Instead, our engineers bring the code back into VERICUT, make their edits, and then hit simulate to check that the program is safe to release. Smashing pixels is much cheaper and safer than writing off a machine tool, so verifying code using a digital twin before we put anyone or anything at risk is an integral part of our workflow. This risk-based approach is absolutely crucial, not just in aerospace and defence, but for any high-value product and business."

May the Force be with you

With VERICUT an established part of Castle's business for the past 12 years, the software has proven its ability to protect the company as well as being a key improvement tool for its manufacturing processes. Yuile states: "VERICUT Force is a step further along this curve. Moving beyond the goalkeeper functionality, Force allows us to start optimizing our processes as well as proving that they are safe."

Every manufacturing business faces the same three challenges from its customers: quality, delivery, and cost. "Generally, quality and delivery are a given, and cost

is where we win or lose," he says. "The pressure within the Aerospace industry on cost is enormous, and for us to stand against global competition, we have to be smarter, faster, and more efficient. Physics-based optimization software has been on our radar for a while, and we started looking at it seriously a couple of years ago."

"There are a few key players in that market, and we evaluated them all. There's a lot of clever math behind it, but the basic idea of physics-based optimization is to analyze a toolpath line by line, calculate the forces acting on the cutting tool at any given point in time, and then adjust the feed rate to balance or control that force and chip load," he adds.

"This means there's a lot of number crunching involved, but before you even get there, you need to build an accurate digital model of the machining process. Since we already simulate every job in VERICUT, the major advantage of VERICUT Force is that building this model takes almost no additional effort - all Force needs is a bit more information on tool geometry and material characteristics; everything else is already there. The cycle time savings you can expect to get from this kind of optimization are typically 10-20 percent, and VERICUT offered an almost 'plug and play' solution for both milling and turning that was really attractive to us," adds Yuile.



Source: CGTech

User-friendliness wins

During the evaluation phase, the engineering team at Castle worked with CGTech UK to create a test case based on an existing process involving both turning and milling, which was provided to multiple software vendors. As Yuile points out, “To be honest, they all came back with broadly similar results for cycle time reduction, but it was the usability that was the differentiating factor for us. We have everything built up in VERICUT already, and because CGTech has done a really good job of making Force as user-friendly as possible, it helps make the benefits of physics-based optimization a lot more accessible.”

He says: “It is exciting, the idea that we can go through our existing workflow, take a job that we have proven as a stable process, and then say, ‘Right VERICUT, analyze this for me and tell me where there’s room for improvement.’”

“The interesting thing is because we are working with a lot of difficult-to-machine materials, it’s not always about cycle time. It sounds counterintuitive, as typically, the main benefit of optimization is the opportunity to speed things up, but sometimes it’s also about slowing things down to reduce peak loading on

the tool. Smoothing out spikes in cutting force or chip load can have a major effect on tool life, but it is harder to quantify the benefit as you can’t tell until you go and try it,” he adds.

“On one of the jobs we were analyzing recently, we were looking at a histogram of chip load and seeing that for maybe 5 percent of the time it was twice as high as the average load, telling us that there were regular spikes throughout the tool path. Now we have the ability to identify where these occur and slow the feed rate to level them out, reducing tool wear and improving both tool life and process stability.”

Reducing consumables spend

Force has been in use at Castle for about a year, and Yuile is keen to highlight one of the often-overlooked benefits—consumables spend. He says: “Carbide cutting tools are a major expenditure for us. When we are costing a job, the two key variables are how long it is going to take on the machine and how much we are going to consume in carbide. Any reduction in cycle time Force can deliver is good, but so is any improvement in tool life.”

“Although cycle time is a monetary saving in the sense that you free up machine capacity

that you can sell to somebody else, consumables are direct cash spend. If it takes £100 of carbide to make a particular part and we can reduce that to £80, we are literally not spending £20. That’s £20 that stays in our bank account. Cycle time savings are soft money; they’re potential revenue, while consumables spend is hard money; it’s cash.”

Partners in progress

Castle has always been an early adopter of manufacturing technology, and VERICUT has established itself as an essential part of the company’s digital workflow. “We put a lot of effort into ensuring our simulations are an accurate representation of the real process, as the benefits VERICUT delivers are massive, both as a safety net and as an improvement tool. All of our programming is done offline, and being able to accelerate the proving out of new jobs by doing most of it virtually saves a huge amount of production downtime, as well as derisks the entire process.”

“We trust VERICUT,” Yuile concludes, “and that trust comes from experience. When manufacturing high-value components for such critical applications, we need to have confidence that we’re using the very best tools for the job, and VERICUT delivers.” 

Castle has everything built up in VERICUT already, and because CGTech has done a really good job of making Force as user-friendly as possible, it helps make the benefits of physics-based optimization a lot more accessible.

TRANSFORMING FOR GROWTH

Digital transformation is proving itself to be highly crucial in making everyday manufacturing operations faster and easier. Here's knowing the role new-age tech platforms are playing in bringing a sustainable shift in the digitization of the manufacturing industry...



Source: Magic Wand Media

Digital transformation is revolutionizing the industry in the same way as the 'Industrial Revolution' revolutionized manufacturing. However, manufacturing is one of the industries that has been slow to adopt digital transformation at both the corporate and operational levels.

Manufacturing organizations are beginning to utilize technology to make the switch from traditional business models to futuristic ones, and we are definitely seeing an uptick now. Furthermore, buyers' expectations and the emergence of interoperability and connected platforms are driving digitization.

The industry will continue to evolve in response to the issue of ensuring the delivery of appropriate products to the right person at

the right price via a more sophisticated procedure. Here's how new-age tech platforms are proving instrumental in bringing a sustainable shift in the digitization of the manufacturing industry.

Industry 4.0 and the evolution of manufacturing employment

Manufacturers in the era of Industry 4.0 need to be knowledgeable, connected, flexible, and customer-focused. Future factories must run without a hitch, delivering goods on schedule, of acceptable quality, and with the least amount of scrap and rework possible. Additionally, manufacturing must provide more personalized items, affordable rates, and quick turnaround times. Since it's a big task, Industry 4.0 calls for cutting-edge software and technology.

As a result of increasing interconnection and intelligent automation, the Fourth Industrial Revolution predicts fast change in technology, industry, and societal patterns and processes in the twenty-first century. Today, businesses are creating the groundwork for connectivity and a single IT/OT (information technology systems with operational technology) digital platform. Apart from 4G/5G, more technologies are now emerging to assist Industry 4.0 work in challenging conditions.

The significance of Industry 4.0 becomes even more obvious against the backdrop of a crisis like COVID-19. Players using digital solutions were better positioned to weather the storm because they could move more quickly and far during the cri-

DR RAUNAK BHINGE
Founder & CEO
Infinite Uptime



sis than their competitors. The organizations have benefited from the accelerated adoption of quick-win solutions that assist businesses in responding to and adapting to the new norms, such as tracking employee health, ensuring safe distancing on the work floor, and facilitating remote collaboration. Regardless of a company's current IT infrastructure, use-cases relying on digital work instructions, augmented reality-based operator aid, and easy, affordable retrofit automation may also become increasingly common. Digital performance management (DPM) has also been a well-liked early use case at various businesses, including numerous small precision engineering firms, where DPM pilots have helped increase productivity by 40 percent to 70 percent.

According to a NASSCOM-Capgemini report titled, 'India Industry 4.0 Adoption: A Case to Mature Manufacturing Digitalization by 2025', Industry 4.0 can help the Manufacturing sector contribute 25 percent of GDP by FY26, paving the way for India's Manufacturing sector to become an intelligent industry. The boost will help India's Manufacturing sector achieve the national growth target of US\$1.1 trillion by FY26.

Digital transformation with new-age tech solutions

The Indian Industrial sector has already started to pivot towards digitalization, thanks to increased investment in foundational technologies such as the Cloud and IoT. By 2025, more than two-thirds of India's Manufacturing industry will likely have adopted Industry 4.0. Businesses will start focusing on new business models and understanding that end customers expect new, intelligent goods.

Discrete manufacturers in Auto, Electrical, and Electronics account for 75 percent of total tech spending, while Chemicals and Pharma top the Process Manufacturing industry. Although the industry has hurdles in scaling up Industry 4.0 technologies, financial and leadership constraints provide an opportunity to address these issues. Digital solutions that can help businesses flourish include:

- Cloud and SaaS-based solutions to outsource non-core tasks to reduce fixed costs.
- AI-based computer vision to reduce the cost of quality checks and address defects.
- Big Data Analytics to minimize risk effects.

Another emerging new-age tech includes predictive maintenance (PdM), which encompasses a wide range of approaches for detecting early symptoms of equipment faults, allowing operators and maintenance personnel to intervene before a breakdown occurs. PdM programs that are successful lower the need for unscheduled maintenance interventions. This lowers maintenance expenses while increasing output and throughput, especially for assets that are capacity constrained. Furthermore, these programs can extend the useful life of high-cost components while lowering the chance of machine failure.

The key forces behind the Manufacturing sector's digital transformation are shifting consumer expectations and fierce competition. Using digital technology, manufacturers may increase speed and efficiency, cut costs, and provide superior consumer experiences. The epidemic has made manufacturers more aware of their company's operational flaws and limitations. For instance, they now recognize the need to have ac-

cess to real-time supply chain data so they can respond to supply problems and demand rises more swiftly. Modern technology has enabled the industrial sector to efficiently use digital technology to improve operational procedures and increase supply chain efficiency. Supply chain systems are now connected, thanks to digital transformation, which can assist manufacturers in gathering equipment data by utilizing AI and predictive analytics.

The way forward

Global humanitarian issues brought on by the COVID-19 epidemic demand a new kind of cooperation to solve problems. Organizations have the chance to reimagine a future with digitized, resilient operations as they restart their operations in the new normal. Early successes have demonstrated that businesses can begin to reboot and quickly scale up if they commit to the transformation of Industry 4.0 in accordance with their business environment and strategic goals. The Manufacturing industry has reached an unprecedented yet unavoidable tipping point with Industry 4.0. In the next two years, there is an urgent need to increase investments in digitalization and hasten the deployment of an ROI-driven and outcome-based strategy. Enterprises in the area should prioritize investments in new technology, Big Data Analytics, central and remote-controlled monitoring, and process automation over the next 18-24 months. Scaling up existing IoT and Cloud deployments to develop new use cases and industrial automation will require a mix of these new investments and innovations. Only then will the Manufacturing industry be positioned to capitalize on the available digital solutions and make a sustainable business impact. 

The Manufacturing industry has reached an unprecedented yet unavoidable tipping point with Industry 4.0. In the next two years, there is an urgent need to increase investments in digitalization and hasten the deployment of an ROI-driven and outcome-based strategy.

CONVERGING STRENGTHS

India-Taiwan relations have been developing for some time, and now that bilateral trade has reached new highs, both countries are expanding their collaboration to achieve a common goal: growth.

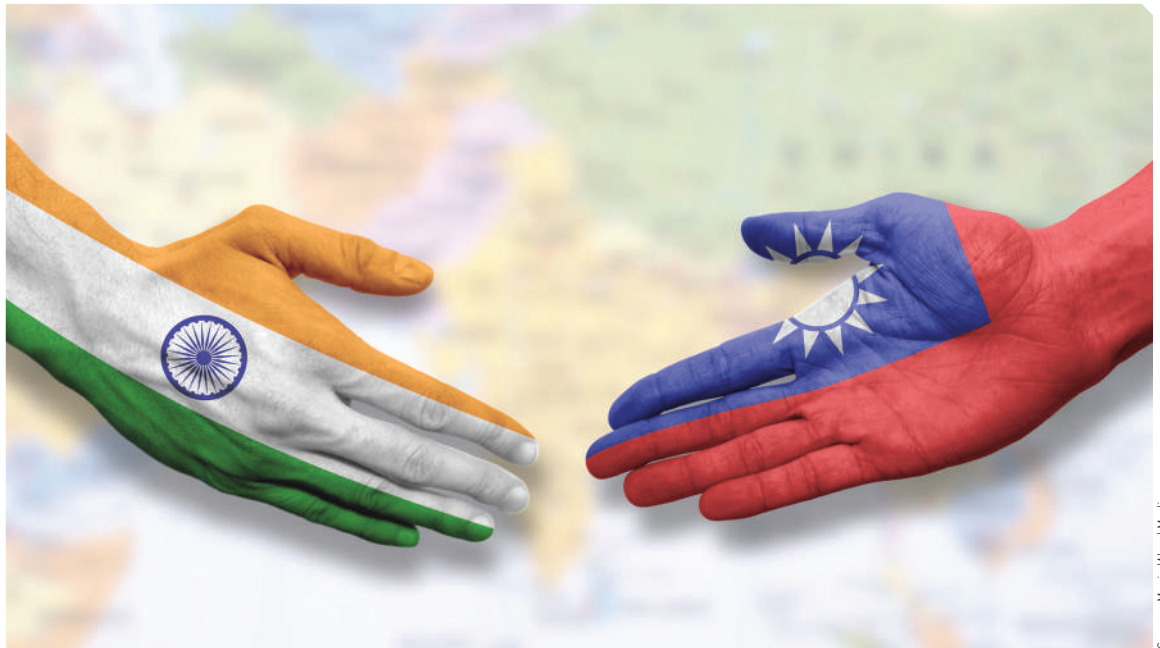

Source: Magic Wand Media

India and Taiwan have established a robust economic relationship, and talks to sign a Free Trade Agreement are currently underway, likely strengthening the countries' steadily improving relations.

Taiwan has the world's greatest concentration of machine tool manufacturing due to its complex machinery and machine tools ecosystem. COVID-19 has raised global demand for less labor-intensive manufacturing processes, boosting Taiwan's smart manufacturing technology, which can assist companies adopt smart manufacturing and Industry 4.0.

Some of the leading Taiwanese Machine Tool companies share insights about their key interest areas in the Indian

market, their offerings, and plans going ahead.

Honor Seiki Co, Ltd

Founded in 1987, Honor Seiki is a leading machine tool provider in Taiwan and globally, with international quality certificates and a solid reputation in CNC Vertical Lathe and Turnkey solutions.

When quality matters

"Thirty of our 200 employees are in R&D, which helps us have the edge over the competitors," says Joseph Chen, Vice President, Honor Seiki. "Our efficiency, precision, and quality are easily as good as similar models made by Italian competitors, but with a far better price-performance ratio."

He elaborates, "Not only spin-

dles, but also over 95 percent of critical components are self-designed, self-manufactured, and self-inspected. The comprehensive know-how, developed and completed in-house, ensures a precise and reliable quality. Our quality system is in compliance with international quality standards and is certified by ISO."

Focusing EV & aerospace sector

Aerospace is one of the company's primary focus industries, and Chen explains, "We need to develop technology for future industry trends like lean manufacturing, intelligent 4.0, and carbon-neutral. Our vision is to be the most innovative and leading vertical lathe solution provider in the entire global markets."

SOUMI MITRA
Editor-in-Chief
Modern Manufacturing
India
soumi.mitra@
magicwandmedia.in





Source: Honor Seiki Co., Ltd

“As long as customers provide workpiece drawings and the volume of mass production, Honor Seiki prides itself on providing maximum customer satisfaction from planning, design, manufacturing process analysis, cycle time, jig, fixture design, tool configuration, and turn-key engineering to product completion. This ability will certainly help us to reach the major players in the Indian Automotive market.”

Joseph Chen
Vice President
Honor Seiki Co., Ltd

“We are proud to say we are ready,” he adds, talking about the prospects in the Indian auto market, particularly in the Electric Vehicle (EV) segment. “The EV market is a booming market. Lightweight workpieces and new materials are Honor capabilities that can help customers speed up their production and improve cycle time for better performance.”

The company is a part of TTG Group and has extensive experience in the Automotive industry. Elaborating on its offerings, Chen says, “Through TTG Group, we provide comprehensive total solutions for the Automotive industry. For example, Alloy Wheels systems-Tongtai, Braking systems-Honor, Battery Pocket-PCI/ANGER, and Mold of bumpers/Large automotive components-APEC.”

Global and Indian footprint
It has a worldwide sales



Source: Shieh Yih Machinery Industry Co., Ltd (SEYI)

“The Indian EV industry is picking up pace with new manufacturing hubs from FDI and improvement in charging infrastructure. A vast domestic market is targeted by many auto OEMs. For equipment suppliers like SEYI, we will definitely pay close attention to the opportunities in the Indian auto market in the next few years.”

Steven Lee
Vice President - Sales
Shieh Yih Machinery Industry Co., Ltd (SEYI)

network presence in advanced countries such as Germany, France, Italy, US, UK, and Czech Republic. China, Russia, Central and South America, India, and the Asia-Pacific region are now its priority markets. Some of its major international customers include Metso, Thyssenkrupp, and Winhere.

Intelmac Machine Tools Pvt Ltd and Phillips Machine Tools India Pvt Ltd represent the company in India, and its customers include AMTEK, Rothe Erde India, and Timken Engineering Research India.

Shieh Yih Machinery Industry Co., Ltd (SEYI)

SEYI is a global leader in middle and large servo presses with over 60 years of experience. Automobile applications account for more than half of total sales revenue, followed by consumer electronics, household appliances,



Source: Yeong Chin Machinery Industries Co., Ltd (YCM)

“By adding value through advanced applications and intelligent solutions, we can offer total and customized solutions to end-users based on their requirements through research and planning from customer situations. As companies are moving towards upscale production, one of the challenges ahead will be increasing productivity with limited resources, especially skilled labor.”

Hank Wu
Sales Engineer
Yeong Chin Machinery Industries Co., Ltd (YCM)

es, and other fields. Moreover, the company is being acknowledged by an increasing number of OEMs and Tier 1 and Tier 2 auto suppliers.

Staying afloat

Steven Lee, Vice President - Sales, SEYI, states that the impact of COVID-19 beginning in 2020, resulting in lower demand, supply chain disruption, and factory shutdowns in the Auto industry, has drastically reduced demand for metal stamping in the industry.

“Luckily, the stamping market still has some other applications to support its foundation and will not shrink too much. Consumer electronics, home appliances, cloud computing, and healthcare industries may help to sustain the market,” adds Lee.

Expanding reach

The company exports mid-and

Honor Seiki is represented in India by Intelmac Machine Tools Pvt Ltd and Phillips Machine Tools India Pvt Ltd, and its customers include AMTEK, Rothe Erde India, and Timken Engineering Research India.

The company's customers include Maruti Suzuki and Tier 1 automotive suppliers. Its agents in India are AY Enterprises for Chennai, Tamil Nadu; Sakar Engineers for Mumbai, Maharashtra, and Gujarat; and Goodwill Imex for Bangalore, Karnataka, and Delhi.

large-tonnage presses to the US and China, and mid- and small-tonnage presses to Southeast Asia and India for automotive applications.

"We can say that this relates to the division of labor in the global automotive supply chain," claims Lee. "Large metal parts, such as body shells and frames, are produced close to the assembly plants, while smaller auto parts such as filters or brake disks are produced in Southeast Asia."

The company's customers include Maruti Suzuki and Tier 1 automotive suppliers. Its agents in India are AY Enterprises for Chennai, Tamil Nadu; Sakar Engineers for Mumbai, Maharashtra, and Gujarat; and Goodwill Imex for Bangalore, Karnataka, and Delhi.

Reducing carbon footprint

Compared to traditional presses, SEYI's servo presses use a direct-drive design without flywheels and a deceleration mechanic, thus reaching better accuracy and energy efficiency. "Unnecessary press movement can be eliminated, the production output can be doubled, and up to 50 percent of electrical power consumption can be saved," says Lee.

SEYI's servo presses do not require water cooling systems to sustain servo motor performance because the motor design is based on the concept of high efficiency. "Only a fan-cooled system is sufficient, leading to a more energy-efficient, space-saving, and economical choice for metal stampers," he adds. "Meanwhile, the noise value of a SEYI's servo press is reduced by 30 percent compared with a traditional mechanical press." In addition, SEYI's Smart Press Solution deploys small but accurate sensors to monitor machine status in real-time, reducing unexpected downtime.

Strategies for the Indian market

SEYI has been in the Indian market for a very long time. "Last year, we had an excellent performance in India, thanks to the economic recovery in the post-pandemic era. SEYI will continue to work with our local partners and directly communicate with the end customers for detailed product promotion," Lee confirms.

He adds, "Again, we think the challenges faced by EV-related suppliers in other countries will be the same as those of Indian suppliers. We can use our experiences based on past success cases and share them with the local customers. This can eliminate their concerns when implementing a new technology such as servo presses."

Yeong Chin Machinery Industries Co, Ltd (YCM)

Founded in 1954, Yeong Chin Machinery Industries Co, Ltd (YCM) specializes in machine tool manufacturing. Its machine tools have been recognized worldwide for superior precision, outstanding rigidity, and exceptional reliability.

Smart manufacturing solutions

"With over 70 different product models and nearly 70 years of machine tool manufacturing experience, the company's YCMPS product model promises 'sustainable development', allowing YCM to become the best machine tool manufacturer in the world," says Hank Wu, Sales Engineer, YCM. "YCMPS, based on the Toyota Production System (TPS) and lean management concepts, is motivated to produce equipment from metal casting to machining, assembly, quality control, packaging, and all the way to shipping."

Following the COVID-19 pandemic, the company intends to provide innovative smart manufacturing solutions based on the rapid development of AI, Big Data, Cloud Computing, the Internet of Things (IoT), and 5G communication.

Smart machines and management

The company has introduced its own intelligent HMI iCube with an intuitive and user-friendly graphical design interface to add intelligent functionality to the standard features of Fanuc, Siemens, and Heidenhain controllers, providing customers with an enhanced and efficient operating experience.

"The smart functions are embedded in the software for YCM machines to allow machines to rough machine faster while providing improved profile accuracy during the finishing process," explains Wu. "YCM also provides value-added analysis of the machining process to optimize the machining parameters to achieve faster machining with better surface finish and tool life."

Intelligent, flexible manufacturing cell

Equipped with a robot, UV650-FlexCell offers automatic side loading and unloading from part storage to the machine. The advanced UV650 5-axis vertical machining center provides excellent cutting performance and high accuracy for simultaneous 5-axis applications with just one setup. Designed to reduce part handling, setup, and overall lead-time, it also improves part quality, precision, and surface finish of complex shapes and contours required for multiple industries such as job shop, medical, aerospace, and die & mold. 

INNOVATION IS KEY

Bharat Fritz Werner Ltd and m2nxt launched India's first commercially available Laser-Directed-Energy-Deposition (L-DED) machines with Hybrid and Robot configurations on June 1, 2022, at their Bengaluru headquarters.



L-R: Dr Ashwath Narayan CN, Minister of Electronics, Information Technology - Biotechnology, Science and Technology, Higher Education, Skill Development, Entrepreneurship and Livelihood, Government of Karnataka, along with Ravi Raghavan, CEO, BFW Ltd at the launch of the Photon 1000H and the Photon 1000R, at BFW's Bengaluru headquarters.

Bharat Fritz Werner Ltd (BFW) and m2nxt (a BFW subsidiary), India's leading CNC and Industry 4.0 machines and solutions companies, have launched the Photon 1000H and the Photon 1000R, India's first commercially available Laser DED-based Hybrid and Robot Metal 3D Printing machines.

The formal launch ceremony for the Photon 1000 series took place on June 1, 2022, at the BFW headquarters in Bengaluru, at the hands of the Chief Guest Dr Ashwath Narayan CN,

Minister of Electronics, Information Technology - Biotechnology, Science and Technology, Higher Education, Skill Development, Entrepreneurship and Livelihood, Government of Karnataka and the Guest of Honor Dr Vijay Kumar Saraswat, Member, Niti Aayog and Former Director General, Defence Research and Development Organisation (DRDO) and Chief Scientific Advisor to the Indian Minister of Defence, who was present online.

Also present were TR Parasuraman, President & Wholtime Di-

rector, Toyota Industries Engine India Pvt Ltd; Dr S Devarajan, Sr Vice President, TVS Motors Company Ltd; Jaspreet Sidhu, CEO-NCAM; Brian Matthews, Chief Technology & Innovation Officer, Meltio, along with several senior government and industry officials and experts.

Tuned to market demands
BFW specializes in cutting-edge advanced manufacturing technology platforms, with over 50,000 machines and systems installed worldwide. Sensing the industry's needs

SOVAN TUDU
Sub-Editor
Magic Wand Media Inc
Sovan.tudu@
magicwandmedia.in



The Photon platform includes the world's largest and fastest L-DED game-changer Photon 4000G, which was announced in April 2022. And now the Photon 1000H and the Photon 1000R, hybrid and robotic configurations.

and the opportunity for cost-effective and large-format metal additive manufacturing (AM) in the Laser-Powder and Laser-Wire Directed Energy Deposition (DED) segment, it entered the DED metal AM industry in September 2021 with a mission to industrialize additive technology.

BFW's 60 years of expertise in machine tools gives it the capability and infrastructure to develop and manufacture a complete end-to-end range of AM solutions (Photon Platform) to exacting specifications and reliability. The Photon platform includes the world's largest and fastest L-DED game-changer Photon 4000G, which was announced in April 2022. And now the Photon 1000H and the Photon 1000R, hybrid and robotic configurations. The entire product range of the Photon platform is among the most commercially attractive yet highly capable technologies with strong validation in the academia and industrial applications for

Aerospace, Defence, Medical, Die & Mould, and Energy segments. BFW also provides world-class customer support for installation, commissioning, training, and expert consultancy to any customer within India and worldwide.

Photon 1000 Series

The Photon 1000H is a hybrid machine that combines subtractive and additive technologies, whereas the Photon 1000R is an additive manufacturing machine with a robot combination. These machines are intended to address smaller components and were developed in cooperation with BFW partners, Meltio, a Spanish startup. The Photon 4000 in this range is the largest printing machine globally, which has been designed and will be manufactured in the coming months.

With a vision to bring Additive Manufacturing (AM) machines to every shop floor and to make them available to work 24x7, Ravi Raghavan, CEO, BFW and President, Indian Machine Tool Manufacturers' Association (IMTMA), explained, "We will match AM as a complementary product for Subtractive so that they are as fast and cost-per-piece sensitive as possible. With a strong association with the Automobile industry, we have learned to make machines using a platform-based approach. With this philosophy, we have developed the whole Photon range of AM machines, through which we want to address the maximum application size and materials. We

hope that by sharing these solutions, we will be able to contribute to our Hon'ble Prime Minister's Aatmanirbhar Bharat and the vision of the state of Karnataka."

Industry viewpoints

On the newly launched machines, Dr Saraswat said, "It makes India proud that today we have the capability to indigenously manufacture such complex machines which have got technologies starting from robotics, energy deposition systems, and so on. This augurs well for India's self-reliant journey, and we are happy that this movement has come."

He added, "From the design and engineering and manufacturing perspectives, it will help designers with fast prototyping, faster time-to-market, greater customization, new designs and functionalities, and faster, more flexible manufacturing processes with fewer production steps and dedicated machines."

Pointing to AM's significant benefits, Parasuraman added, "It does not need fixturing or tooling. There is no setup or change over time from one product to another. It offers flexibility, ergonomics, and sustainability. Every MSME or Manufacturing industry should consider this option."

Coining additive manufacturing as a game-changer, Devarajan asserted, "New things are coming up in the two-wheeler segment, and probably in the next four or five years, the design of the two-wheeler itself will change. The challenge we might face as an OEM is that we should be designed for additive manufacturing. It cannot be just like replacing any part that you make by additive manufacturing, so the onus lies with us. We must design productive manufacturing work along with the



Source: Magic Wand Media



Source: Magic Wand Media

function rather than the component or a combination of parts. I think the most important thing for all of us is to work together, and I think it's a really good starting point."

"These commendable efforts contribute to our nation's 'Make in India' initiative instrumentally. As most of us probably know by now, DED is a native manufacturing process in which focused thermal energy is used to fuse materials by melting as they are being deposited when coupled with CNC machining in a single hybrid equipment," commented Sidhu. "DED is also used for structural parts and commercial aircraft components. Several foreign private players have amazed the world with technological advances. Most of them are supported by brilliant Indian scientists and engineers, but now it's time to build and export the technology developed by Indians."

Getting into the specifics

Deep diving into the technical aspects of the machine, Matthews from Meltio, a disruptive laser metal deposition technology manufacturer and BFW's official value-added partner, spoke on the prospects of the machines. He said, "I think they'll do well in this market, given industry trends. I think DED, or

directed energy deposition, will gain market share. This process is unique because we use multiple laser sources, which gives us an interesting architecture where the material feeds on the axis, which is crucial for excellent material properties and geometrical capabilities."

"DED laser-based technology will grow in metal AM and traditional manufacturing, so you'll see two growth curves," he added.

Elaborating on the hybrid metal wire process, where 100 percent of the material ends up in the parts, Matthews further stated, "This technology can use more than one material in the same part, which has fascinating applications. You don't normally see this in the industry because the mindset for design has been that you have a part, a geometry, and you build it out of one material. With this technology, you can add two materials to the same part to gain performance, cost, or both."

Extending government support

Congratulating the BFW team on their successful launch and stating that with the latest technologies and improvisation coming up with new missions to add more value, the Minister said, "Earlier, technologies had a greater environmental impact,

but now environmental protection and sustainability are the way forward to make it net-zero. Saving material, time, and technology and making better products and quality are ways to pursue excellence and ensure we are the best in the world. So in this direction, the state of Karnataka, under the leadership of our Honorable Prime Minister and Chief Minister, has been adopting industry 4.0, as the industry is moving forward simultaneously for your demand and supply."

He also emphasized the importance of manpower in the adoption of Industry 4.0, as well as how the state has done so in various sectors. "Not only adapting, but also implementing the right platform, integrating technology, reforming governance and administration, and bringing the latest legislation to ensure the institution's empowerment; all have been done," he added.

Working towards a vision to make Karnataka the national capital for additive manufacturing and assuring the Dias, he concluded, "What you have been looking for will be supplemented, and will be ensured by our state institutions not only for Karnataka but for the entire nation. So, whatever the requirement, we are willing to address the requirement and will collaborate." 

The Photon 1000H is a hybrid machine that combines subtractive and additive technologies, whereas the Photon 1000R is an additive manufacturing machine with a robot combination.

IMTEX FORMING 2022: BACK IN FORM

Back with renewed vigor, IMTEX FORMING 2022 enthralled the visitors who had come from all over the country and beyond with innovative solutions from the metal forming field. Eager to update themselves on cutting-edge technologies, the participants reciprocated with the same measure of enthusiasm and hailed it as a much-needed event.



Source: Magic Wand Media

POONAM PEDNEKAR
Chief Copy Editor
Magic Wand Media Inc
poonam.pednekar@
magicwandmedia.in



Organized by Indian Machine Tool Manufacturers' Association (IMTMA), IMTEX FORMING 2022 garnered an overwhelming response from the exhibitors and visitors who had gathered under one roof to witness the latest in the field. Held from June 16-21, 2022, at Bangalore International Exhibition Centre (BIEC), Bengaluru, the six-day trade fair had

Tooltech and Digital Manufacturing as its concurrent shows. Institutional buyers from 250 companies across India from sectors like Aerospace, Defence, Railways, Power, Electronics, Medical Equipment, Textiles, Agriculture, Turbines, etc. visited the show. Delegations from leading public and private entities like Ashok Leyland, Bajaj Auto, BEL, BHEL, Havells, Hawkins,

HAL, Hero Motors, Infosys, Rolls Royce, ISRO, L&T Construction, Railways, Tata Sikorsky, Titan, Toyota, TVS Motors, among others, visited the exhibition.

Bringing back positivity
Optimism loomed large as the prominent veterans of the industry physically gathered to flag off IMTEX FORMING 2022. Their reflections on the re-

Source: IMTMA



cent challenges, the resilience demonstrated by the industry, its current stable state, and the opportunities that await us in the global scheme of things, set an encouraging tone for the event.

The exhibition was inaugurated in the presence of the Guests of Honor Shri Ashwathnarayan CN, Hon'ble Minister of Higher Education, IT & BT, Science and Technology and Skill Development, Government of Karnataka; Dr K Sivan, Dr. Vikram Sarabhai Distinguished Professor & Former Chairman, ISRO; Ravi Raghavan, President, IMTMA; Rajendra Rajamane, Vice President, IMTMA; PJ Mohanram, Principal Advisor, IMTMA;

and Guru Prasath KR, Executive Director - Trade Fairs.

Raghavan, in his welcome address, shared that the Indian Machine Tool industry is on a recovery path from the pandemic-induced setbacks and revealed that its production is to reach around ₹9,500 - ₹10,000 crore in the year 2022-23. IMTMA and the industry are working towards improving the domestic market share from 50 percent to 65 percent in the next few years.

Together to grow

IMTMA and Indian Institute of Welding (IIW), Pune, signed an agreement at the event to jointly organize WELDEXPO, an exhibi-

tion on welding and cutting, from IMTEX FORMING 2024 onwards at BIEC. In this backdrop, Guru Prasath KR, Executive Director, Trade Fairs, IMTMA, shared, "The ecosystem of the Welding industry is used by the metal forming community. This MoU will facilitate direct interaction between them, benefiting both industries."

Live demo on Industry 4.0 concepts

Keeping up with the industry trends, IMTMA organized a live demo on Industry 4.0 as part of IMTEX FORMING 2022 at its Technology Centre. A model smart factory was set up where a CNC turning center, a

The Indian Machine Tool industry is on a recovery path from the pandemic-induced setbacks and its production is to reach around ₹9,500 - ₹10,000 crore in the year 2022-23.

Source: Magic Wand Media



IMTMA and Indian Institute of Welding (IIW), Pune, signed an agreement at the event to jointly organize WELDEXPO, an exhibition on welding and cutting, from IMTEX FORMING 2024 onwards at BIEC.

CNC machining center, a digital height gauge, and CMM machines were digitally connected and monitored in real time. The real-time data was acquired through the data acquisition devices and CNC controls.

Partnering for progress

IMTMA, in its endeavor to forge a strong connection between the industry and the academia, offers the platform of the i2 (industry-institution) Pavilion to the Indian academic/R&D institutions to showcase their R&D capabilities in the metalworking field at IMTEX every year.

CMR Institute of Technology, Bangalore, won the First Prize for: Additive Manufacturing for Medical Implants; Vemana Institute of Technology, Bangalore, won the Second Prize for: Dynamic Behavior of Materials; KLS Gogte College, Belagavi, bagged the Third Prize for: Joining of 3D printed parts by FSW technique to overcome the bed size limitation of an FDM 3D printer applied to UAV wings; Dr Vishwanath Karad MIT World Peace University, Pune, won a Consolation Prize for: Micro Forming Analysis of Aerospace Materials; Indian Institute of Technology, Bombay, won a Consolation Prize for: Advanced Manufacturing.

Industry delegates' take

IMTEX 2022 enthralled industry insiders who visited the trade fair to update themselves

on the latest developments in the field. Vikram S Kasbekar, Executive Director, Operations (Plants), HeroMoto Corp, made the most of his short visit to IMTEX and found the machine and technology suppliers he was looking for. Rajagopalan R, Chief Manufacturing Officer, Watches & Wearables, Titan Company Ltd, who had just returned from a Geneva watch industry exhibition, drew parallels between that and IMTEX 2022. He shared, "I find all the technologies that I witnessed at the Geneva exhibition here at IMTEX. We are on par with them. I am proud to say that a few technologies being shown here are better than those displayed there."

A team of delegates consisting of technology experts, consultants, and trainers from Bangalore Chamber of Industries & Commerce (BCIC) also visited IMTEX 2022. Dr S Devarajan, Co-Chairman, Manufacturing Expert Committee, BCIC, and Senior Vice President, Production Engineering, said that IMTEX is an opportunity to see the changes happening in the field of technology and the way new technologies can deliver competitiveness among manufacturers.

Self-reliance is crucial

The maiden 'AatmaNirbhar Bharat Pavilion' at IMTEX 2022 showcased indigenous technological capabilities and solutions developed in India. At the show,



"We hope that at this IMTEX, we will be able to expand the boundaries of SmartFix4.0 to include applications in industry segments like aerospace, EV and battery manufacturing, railways and defence, textile and agricultural equipment manufacturing, medical equipment, electronics, semiconductor equipment and renewable energy."

Reji Varghese
Managing Director
RV Forms & Gears LLP

Nimble Electric, part of UCAM, was at the fore and introduced its high-performance, energy-efficient, compact, and superior quality Orion, Phoenix, Topaz, and Opal Torque Motors that have been exquisitely crafted using magnetic grade steel, H class insulated copper, and high-temperature, high-strength neodymium iron boron magnets. S K Saha, Vice President, Marketing, Electropneumatics & Hydraulics (I) Pvt Ltd, emphasized that AatmaNirbhar Bharat, or Self-reliant India, is the vision of the new India and that the Government of India's bold reforms will greatly benefit the industry. The company featured a live demonstration of Hydroforming technology, which it has pioneered in India since 2000. Arthi Sairaman, Director, MTAB Engineers Pvt Ltd, said "Our hope is that IMTEX and this pavilion will drive awareness of important technology and product development and

IMTEX FORMING 2022 Snapshot

Total Exhibitors	350
Total Visitors	25,656
Number of Countries	19 including India
Enquiries	Around ₹4,600 crore
Orders	Around ₹500 crore



“IMTEX FORMING 2022 is an ideal platform to relay the news of us taking a plunge into a new business line. We wish to communicate to everyone in the Forming industry that Marposs solutions are now also available for the non-automotive manufacturers. We are now planning to set up our own manufacturing plant also. That way, we have a strong focus on the Indian market.”

Luca Matteucci
Director
Marposs

reach. We would like to thank IMTMA and the Government of India for making it possible for small businesses to bring their products to this show and drive awareness.” The company showcased Kriya AR10-1400, a 10-12 kg payload 6-axis articulated robot with a welding application. It has been developed and commercialized by MTAB under the Government of India’s Department of Heavy Industries initiative and in collaboration with AMTDC (IIT-Madras). Delighted to be part of the



Source: Magic Wand Media



“We have been coming to IMTEX since 1995. It is still the largest exhibition in this field. We now have tube laser cutting machines and laser welding machines and the expo gives us a unique platform to get noticed in the market by all potential customers and related market segments. We expect to connect with furniture industry, job shops, retail showrooms, fitness equipment, building sheds etc.”

Sharad Avasthi
Proprietor
Sharda Engineers

pavilion, Renganathan C, CEO, Chennai Metco, displayed a Robotic Grinder/Polisher and a high-precision 3-Axis Automatic Cutting machine. “It is a step towards Industry 4.0. It offers intelligent, hands-free grinding/polishing solutions with high repeatability,” he said, elaborating.

Exhibitors’ views

Dr Arvind Patel, CEO, Valgro India Ltd, has high regard for IMTEX. “It is India’s most anticipated Expo for the sheet metal forming market,” he said.



“Crisis brings opportunities to rethink and adapt to new challenges, and during the pandemic, we saw more customers investing in automation and moving away from dependence on skilled manpower. Customers want to automate not only blanking but bending as well. So, every single system must be able to collect, process, manage, and correct information associated with the specific process it is involved with.”

Puneet Sharma
Director
Salvagnini Machinery India Pvt Ltd

Echoing similar sentiments, Rajesh Sharma, General Manager, IPG Photonics India Pvt Ltd, shared that IMTEX 2022 was a great platform for IPG India to enlighten people and propagate the message of the application of fiber lasers replacing conventional methods.

IMTEX FORMING is one of the most notable exhibitions in India to connect with the audiences, according to Tushar Pawar, National Head, AMPCO METAL India Pvt Ltd. “It plays a critical role in the development of the Metalworking industry



The maiden ‘AatmaNirbhar Bharat Pavilion’ at IMTEX FORMING 2022 showcased indigenous technological capabilities and solutions developed in India.

IMTMA offers the platform of the i2 (industry-institution) Pavilion to the Indian academic/R&D institutions to showcase their R&D capabilities in the metalworking field at IMTEX every year.



“With these high-quality products made in Germany, excellent results can be achieved for automated, mechanized or manual cutting. Kjellberg’s subsidiary Kjellberg Cutting and Welding India in Pune takes care of all activities concerning sales and service in India since 2015. Personal contact with our customers and partners is important to us.”

Vishal Deore
Director
Kjellberg Cutting and Welding India Pvt Ltd

and helps the stakeholders connect,” he added.

TV Mohan, Country Head & Managing Director, Guthle Pressenspannen GmbH, said, “IMTEX is the premier exhibition in the machine tool, cutting tool, and accessories space. We have been an active participant and supporter of this event and IMTMA for several years and will continue to do so.”

According to Maulik Patel, Executive Director, Sahajanand Laser Technology (SLTL) Group, IMTEX has been a platform to showcase the company’s innovative laser solutions to the industry. “Every year, we unveil new laser machines at IMTEX, a tradition we hope to contin-



Source: IMTMA



“IMTEX gives an opportunity to manufacturers in India and abroad to showcase their products. Cutting-edge technology, which was previously not available for Indian customers to see first-hand, is displayed in front of them. This makes customers more confident in opting these products.”

Rakesh Agarwal
Managing Director
Laser Technologies Pvt Ltd

ue. We receive a lot of attention and business opportunities at the expo,” he said.

For Niraj Seth, President, AMADA India Pvt Ltd, IMTEX FORMING 2022 spelt opportunities after a dry spell of almost no exhibitions. The company launched its flagship model VENTIS 3015 AJ series fiber laser cutting machine for the Indian market.

AV Srinivasan, CEO, Meiban Technologies, was keen to be part of IMTEX since many of its customers had been waiting to interact personally and look at its new technologies. It displayed its AC Servo Press Brake BB6020 for the first time in India along with its best-seller ma-



“We hope this edition plays a pivotal role in our growth, as IMTEX is known for being an ideal platform to provide new opportunities for businesses. We have participated with our full potential so we can increase our brand awareness and generate quality leads. This is the right place to meet our customers and decision-makers to grow our clientele.”

Deviprasad Upadhyay
Vice President-Sales
Stamp 'It Robotai & Solutions Pvt Ltd

chine Muratec 20-tonne high-end AC Servo Turret Punch Press Motorum 2048TS.

The tradition continues

The recently held IMTEX FORMING & Tooltech was delayed by six months due to the uncertainty surrounding the pandemic. It brought along some relief to the industry stakeholders who could finally connect with each other physically, have a look and feel of the products, and witness live display of cutting-edge technologies. The next edition of the trade fair will be held from January 18 - 23, 2024, at its usual venue of Bangalore International Exhibition Centre (BIEC), Bangalore, India. 



Company Index

1Factory.....	22	Laser Technologies Pvt Ltd.....	44
AMADA India Pvt Ltd.....	44	m2nxt Solutions.....	41
AMPCO METAL India Pvt Ltd.....	44	Marposs.....	44
Bangalore Chamber of Industries & Commerce (BCIC).....	44	Meiban Technologies.....	44
Beckhoff Automation Pvt Ltd.....	31	MTAB Engineers Pvt Ltd.....	44
Bharat Fritz Werner Ltd.....	41	Natural Battery Technologies.....	20
Castle Precision Engineering.....	33	Nimble ElectricRV.....	44
CGTech India Software Solutions Pvt Ltd.....	33	Quaker Houghton India.....	12
Chennai Metco.....	44	Sahajanand Laser Technology (SLTL) Group.....	44
Electropneumatics & Hydraulics (I) Pvt Ltd.....	44	Salesforce India.....	12
Forms & Gears LLP.....	44	Sharda Engineers.....	44
Gedee Weiler Pvt Ltd.....	12	Shieh Yih Machinery Industry Co, Ltd (SEYI).....	38
Guthle Pressenspannen GmbH.....	44	Stamp 'It Robotai & Solutions Pvt Ltd.....	44
HeroMoto Corp.....	44	Titan Company Ltd.....	44
Honor Seiki Co, Ltd.....	38	Tokyo Big Sight Inc.....	27
ICAD.....	12	Triumph Tool Ltd.....	16
IMTMA.....	10, 41, 44	UCAM Pvt Ltd.....	44
Indian Institute of Welding (IIW).....	44	Ultra Machining Company (UMC).....	22
Infinite Uptime.....	46	Universal Robots.....	12
IPG Photonics India Pvt Ltd.....	44	Valgro India Ltd.....	28, 44
Japan Machine Tool Builders' Association.....	27	Yeong Chin Machinery Industries Co, Ltd.....	38
Kjellberg Cutting and Welding India Pvt.....	44		

Advertiser Index

ACMEE 2023 – www.acmee.in	50-51
Beckhoff Automation Pvt Ltd – www.beckhoff.com/c6025	09
EPLAN India – www.eplan.in	07
Hann Kuen Machinery & Hardware Co., Ltd – www.hardy-tw.com	19
IMTEX 2023 – www.imtex.in	52
Jyoti CNC Automation Ltd – www.jyoti.co.in	03
Lakshmi Machine Works Ltd – www.lmwcnc.com	05
RV Forms & Gears LLP – www.rvformsandgears.com	02



www.mmindia.co.in



**When visibility matters
it is always MMI!**

**Block your space in MMI
and keep getting leads!**

MMI: IMTMA's Official Publication

For Advertising: MURALI SUNDARAM
E: murali.sundaram@magicwandmedia.in | M: +91 9740048390



India's Premier International Machine Tools Show

ORGANISED BY



ACMEE 2023
15th International Machine Tools Exhibition



An AIEMA Initiative

15 - 19 June 2023

Chennai Trade Centre, Chennai, India

TITLE SPONSOR



Machine Tools Metal Forming Metrology Robotics & Automation



PLATINUM SPONSORS



GOLD SPONSORS



SILVER SPONSORS



SIDCO - AIEMA Tower, First Main Road, Ambattur Industrial Estate, Chennai 600 058. Phone : +91 - 73052 82228, E-mail : info@acmee.in

Visit acmee.in for Space Booking

ACMEE 2023
15th International Machine Tools Exhibition

An **AIEMA Initiative**
15 - 19 June 2023
Chennai Trade Centre, Chennai, India

TITLE SPONSOR

SCHUNK

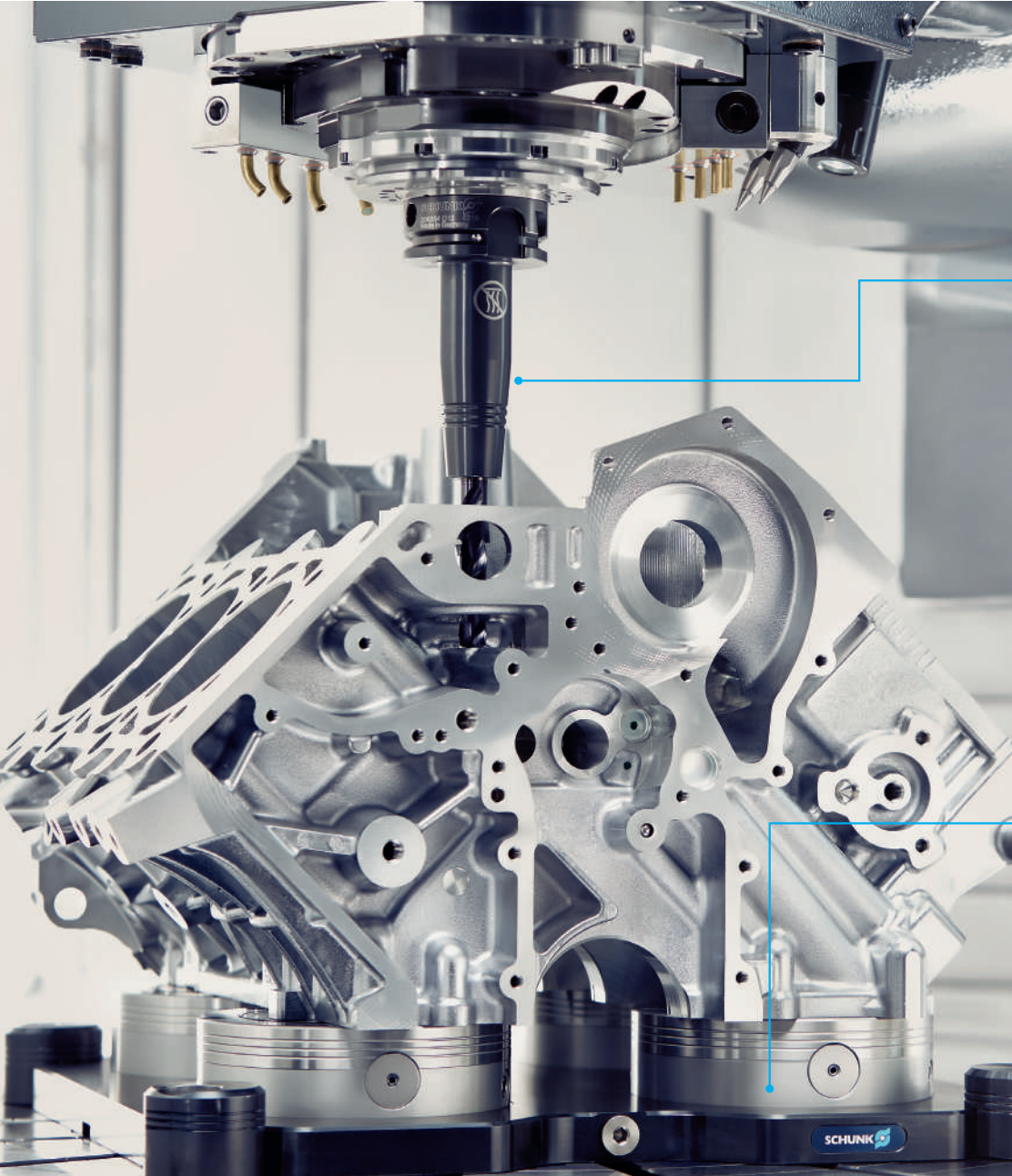

Equipped by
SCHUNK

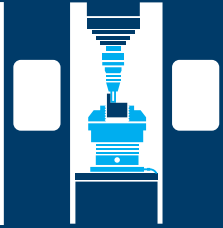

+ **1:1** interchangeable
replacing heat shrinking
toolholders
Hydraulic Expansion Toolholder
T | E | N | D | O Slim 4ax



+ Up to **5**-sided complete/
simultaneous machining
Manual Clamping System
KONTEC KSX



+ Up to **90%**
set-up cost savings
VERO-S Quick-change
Pallet System



Superior Clamping and Gripping

Everything for your
Machining Center

More than 7,500 components for
workpiece and tool clamping.

SCHUNK

schunk.com/equipped-by



Largest Machine Tool and Manufacturing Technology Show in South and South-East Asia



International Machine Tool &
Manufacturing Technology Exhibition



International Exhibition of Cutting Tools, Tooling Systems,
Machine Tool Accessories, Metrology & CAD / CAM

Concurrent shows



International Exhibition on
Industry 4.0 & Additive Manufacturing

19 - 25 January 2023, Bengaluru, India

Key Highlights

- 5 Exhibition Halls
- International Seminar on Machining Technologies
- Aatmanirbhar Bharat Pavilion
- Special Focus on 3D Printing and Industry 4.0
- Academia Pavilion
- International Buyer and Seller Meet

For more information contact: Mr. Deepak Patil, Mob: +91 9892377080, Email: deepak@imtma.in