



# MODERN MANUFACTURING INDIA

WWW.MMINDIA.CO.IN

The Official Magazine of



Indian Machine Tool  
Manufacturers' Association

In Association with



# HYBRID MANUFACTURING The Next Industrial Revolution



**INSIGHT**  
Cutting Tools Market:  
Trends, Growth Drivers, and Future Outlook

24



**MSME-SME SUCCESS STORY**  
Utthunga

52



**AMIT MAHAJAN**  
Director  
Paras Defence &  
Space Technologies Ltd

34

# JH SERIES

Next-Gen Horizontal Machining Centers



- Pallet Size:**  
Up to 500 x 630 mm
- High-Performance Spindles** (BT, BBT & HSK)
- Automatic Rotary Pallet Changer**
- Automatic Tool Changer**  
Up to 72 Tools



Automobile    Aerospace    Agriculture    Pump & Valve    Oil & Gas



**LMW LIMITED**  
(formerly Lakshmi Machine Works Limited)  
**MACHINE TOOL DIVISION**  
+91 422 719 1300 | mtd\_marketing@lmw.co.in

FOLLOW US ON:  
  
 LMW CNC



**1,30,000+**  
Installations across 62 Countries



### Finest Range of CNC Machines

- Turning / Turn-Mill Centers
- Vertical Machining Centers
- Horizontal Machining Centers
- 5-Axis Machining Centers
- Multi-Tasking Machining Centers



### JYOTI CNC AUTOMATION LIMITED

G - 506, G.I.D.C. Lodhika, Village : Metoda, Dist : Rajkot - 360021, Gujarat (INDIA).  
 T : +91-2827-235100/101 | E : info@jyoti.co.in, sales@jyoti.co.in | jyoti.co.in huron.fr

# CONTENTS

VOL 9, ISSUE 1 - MAY-JUNE 2025



14



18



48



38



66

06	<b>FOREWORD</b>	42	<b>ADDITIVE MANUFACTURING</b>
08	<b>PUBLISHER'S NOTE</b>		Tackling the Time-To-Market Challenge
10	<b>EDITORIAL</b>	46	<b>DATA-DRIVEN MANUFACTURING</b>
12	<b>INDUSTRY OUTLOOK</b>		Toward a Future-Ready Factory
	Economy Reflects Upbeat Market Sentiment	48	<b>GRINDING</b>
14	<b>IMTMA'S DESK</b>		It's All in the Grind
	India's Robotic Revolution in Manufacturing	52	<b>MSME-SME SUCCESS STORY</b>
18	<b>TECH TALKS</b>		A Committed Specialist
	Breaking the Iron Ceiling	56	<b>EVENT SNAPSHOT</b>
24	<b>INSIGHT</b>		EMO 2025 World Tour in India
	Cutting Tools Market: Trends, Growth Drivers, and Future Outlook	62	<b>EVENT SNAPSHOT</b>
30	<b>COVER STORY</b>		MODSIM 2025
	Hybrid Manufacturing the Next Industrial Revolution	66	<b>EVENT SNAPSHOT</b>
34	<b>BIG INTERVIEW</b>		DMTX 2025
	Powering Indigenous Defence Capabilities	74	<b>EVENT PREVIEW</b>
38	<b>CUTTING TOOLS</b>		Symposium on Automation & Robotics
	Reliable Micro-machining in Large-scale Production	76	<b>EVENT PREVIEW</b>
			ACMEE 2025

## IMPRINT

**PUBLISHER**  
DIRECTOR GENERAL, IMTMA

**EDITORIAL**  
Editor-in-Chief  
Soumi Mitra

Chief Copy Editor  
Poonam Pednekar

Assistant Editor  
Sovan Tudu

Senior Correspondent  
Murali Sundaram

Correspondent  
Nityasree Kumaraswamy

Design  
Magic Wand Media

**SALES & MARKETING**  
Indian Machine Tool Manufacturers' Association (IMTMA)  
Murali Sundaram, Magic Wand Media Inc  
murali.sundaram@magicwandmedia.in

Published and Printed by Indian Machine Tool Manufacturers' Association (IMTMA). Printed at Pentaplus Printer's Pvt Ltd Sy.No.1/2 Situated at Anjanadari Estate, Lingadeeranahalli, Adjacent to D Group Society Yeshwathpur Hobli, Bangalore North - 560091, Karnataka and Published from Indian Machine Tool Manufacturers' Association; Head Office: 10th Mile, Tumkur Road, Madavara Post, Bengaluru - 562123, Karnataka. Editor: Soumi Mitra

Publishing frequency: 6 times per year

**Manuscripts:** No liability is accepted for unsolicited manuscripts. They will be returned only if accompanied by sufficient return postage.

All rights reserved. Reprints, digital processing of all kinds and reproduction only by written permission of the publisher. Any views, comments expressed are the sole responsibility of the respective authors, IMTMA and Modern Manufacturing India and its partners do not undertake any responsibility, implied or otherwise.

**Disclaimer:** Every effort has been taken to avoid errors or omissions in this magazine. In spite of this, errors may creep in. Any mistake, error or discrepancy noted may be brought to our notice immediately. It is notified that neither the publisher, the editor or the seller will be responsible in respect of anything and the consequence of anything done or omitted to be done by any person in reliance upon the content herein. This disclaimer applies to all, whether subscriber to the magazine or not. © All rights are reserved. No part of this magazine may be reproduced or copied in any form or by any means without the prior written permission of the publisher. All disputes are subject to the exclusive jurisdiction of competent courts and forums in Bangalore only. While care is taken prior to acceptance of advertising copy, it is not possible to verify its contents. IMTMA cannot be held responsible for such contents, nor for any loss or damages incurred as a result of transactions with companies, associations or individuals advertising in its newspapers or publications. We therefore recommend that readers make necessary inquiries before sending any monies or entering into any agreements with advertisers or otherwise acting on an advertisement in any manner whatsoever.

# DON'T LET YOUR COVER SLOW YOU DOWN!

**74 m/min**  
RAPID TRAVEL

DESIGNED FOR ► HIGH-SPEED MACHINING CENTERS

TIENDING Telescopic Covers provide ►

- Seamless motion at high speeds (74m/min)
- Stronger shielding for chips & coolant
- Heavy-duty construction for long-term use
- Optimized for high-speed horizontal machining centers

**TIENDING**  
CUSTOMIZED TELESCOPIC COVER

+886-4-2528 3698  
www.tdcover.com

Sales@tdcover.com  
Taichung City 420, Taiwan.

## HARNESSING INDUSTRIAL INNOVATION FOR STRATEGIC DEFENCE GOALS



*Rajamane*

**RAJENDRA S RAJAMANE**  
PRESIDENT  
IMTMA

Defence manufacturing is strategic to building a technologically empowered, self-reliant nation. The Government of India has launched the 'Innovations for Defence Excellence (iDEX)' scheme to foster innovation and technological advancement in the defence and aerospace sectors by engaging innovators and entrepreneurs in developing advanced products and solutions.

Defence exports have grown severalfold, opening up global market opportunities for Indian industries. Significantly, this transformation is poised to be a game-changer for the Indian machine tool industry, as building such air-defence systems demands ultra-precision components, exotic materials, sophisticated fabrication, and highly engineered products.

This creates opportunities for domestic machine builders to develop and offer precision and ultra-precision machines, robots, cobots and additive manufacturing machines. Certainly, these developments will ignite a new wave of innovation in indigenous machine tool manufacturing, while we have a perfect opportunity to align industrial growth with strategic defence goals.

*IMTMA is organizing the eighth edition of the Symposium on Automation & Robotics 2025, an event that sheds light on the trends in automation and robotics, from June 4 - 5, 2025, at Auto Cluster Exhibition Center, Pune. The event offers an opportunity to connect, collaborate, and discover the innovations that will shape the future of manufacturing.*

The Indian machine tool industry continues its upward trajectory, with production in FY 2024-25 estimated to have increased by 5 percent to reach ₹14,286 crore (US\$ 1.7 billion) while consumption is estimated to have increased by 16 percent to reach ₹31,500 crore (US\$ 3.7 billion) during the period.

To promote the growth of machine tool industry across regions, IMTMA organized the fifth edition of Delhi Machine Tool Expo (DMTX 2025) and the second edition of Factory Equipment Expo (FACTEQ 2025) from May 9 - 12, 2025, at Bharat Mandapam (Pragati Maidan), New Delhi. Both DMTX 2025 and FACTEQ 2025 concluded on an encouraging note.

Looking ahead, IMTMA is organizing the eighth edition of the Symposium on Automation & Robotics 2025, an event that sheds light on the trends in automation and robotics, from June 4 - 5, 2025, at Auto Cluster Exhibition Center, Pune. I warmly encourage readers to mark their calendars for this Symposium as it offers an opportunity to connect, collaborate, and discover the innovations that will shape the future of manufacturing.

Wishing everyone an insightful and engaging read of this edition of MMI.

# END TO END MACHINING SOLUTIONS

INDIA'S LARGEST MANUFACTURER OF MACHINING CENTERS



**HIGH SPEED DRILL TAP CENTERS**



**HIGH VERSATILE VERTICAL MACHINING CENTERS**



**HIGH PRECISION 5 AXES MACHINING CENTERS**



**HIGH PRODUCTIVITY TWIN SPINDLE MACHINING CENTERS**



**HIGH PERFORMANCE HORIZONTAL MACHINING CENTERS**



**HEAVY DUTY DOUBLE COLUMN VERTICAL MACHINING CENTERS**

**AUTOMATION SOLUTIONS**

**IOT SOLUTIONS**

**TOOLEDUP SOLUTIONS**



AUTOMOTIVE



DIE MOULD



ELECTRONICS



AEROSPACE



AGRICULTURE



MEDICAL



GEN. ENGINEERING



RAILWAYS



DEFENCE

- **6000+** Customers

- **70+** Sales & Service Centres

- **15+** Global Locations

- **26,000+** Machining Centers & Counting...

\*Due to continuous updating of machines, images & specifications mentioned herein are subject to change without notice

**ACE DESIGNERS LTD. - MACHINING CENTER DIVISION**

Plot No. 467 - 469, 4th Phase, Peenya Industrial Area, BENGALURE - 560 058. INDIA.,  
T : +91-9880189832 E : helpdesk@amsindia.co.in Web : www.acemicromatic.net

**Ace Micromatic**  
Group



**JIBAK DASGUPTA**  
 DIRECTOR GENERAL & CEO  
 INDIAN MACHINE TOOL MANUFACTURERS' ASSOCIATION  
 BANGALORE INTERNATIONAL EXHIBITION CENTRE

Dear Readers,

Homegrown technology is often more reliable than imported technology, and the latest skirmish that India had with its adversary was a testament to that fact. Elated by this resounding success, the belief in strengthening indigenous capability has become more deep-rooted than ever – that India must lead in defence innovation through homegrown solutions.

A nation is strong in manufacturing when its machine tool (MT) industry is robust – and the Indian machine tool industry isn't a silent partner; it is an enabler. From precision CNC machines crafting the frames of next-generation fighter jets to indigenously designed tools for missile assembly and maintenance, and a wide range of other tools used in defence, the MT industry plays a strategic role.

The vision of 'Atmanirbhar Bharat' is taking shape, with self-reliance taking centre stage across factory floors, R&D labs, and boardrooms. With every gear that turns and every component that fits with perfection, India is forging both technology and sovereignty.

*When we stand firm and tall, leaning less on foreign shoulders, Indian inventiveness will march in lockstep with global standards.*

*As this transformation gains ground across the manufacturing sector, we move toward an era where Indian machine tools take centre stage in building a self-reliant manufacturing ecosystem.*

We are living in a time when the quiet hum of lathes and milling machines blends with the heartbeat of a self-reliant nation. Manufacturing is steadily gaining momentum, becoming a key driver of the emerging economy. Domestic manufacturing is more than producing goods for commercial use – it is a symbol of national grit and technological excellence.

When we stand firm and tall, leaning less on foreign shoulders, Indian inventiveness will march in lockstep with global standards. As this transformation gains ground across the manufacturing sector, we move toward

an era where Indian machine tools take centre stage in building a self-reliant manufacturing ecosystem – confidently bearing the badge of innovation and technological strength. The Indian machine tool industry not only has the power to produce world-class goods but also the ability to propel the nation into a secure and self-reliant future.



## Threading Solutions For Every Applications



1800-3090-112  
 info@addison.co.in  
 www.addison.co.in



*Tools for a changing world*



*Soumi*

SOUMI MITRA  
Editor-in-Chief  
Modern Manufacturing India  
soumi.mitra@magicwandmedia.in

## NOTHING BEATS SELF-RELIANCE AND PREPAREDNESS

**I**n the face of recent geopolitical tensions, India has not only remained unshaken but has emerged stronger and more self-assured. The vision of Aatmanirbhar Bharat, once seen as aspirational, is now shaping the country's economic, strategic, and technological identity.

From strengthening defence capabilities to advancing indigenous manufacturing and fostering homegrown innovation, India's response to global disruptions reflects a profound resilience and a steadfast commitment to self-reliance.

This transformation is a cultural shift—a growing confidence among Indian industries and entrepreneurs to innovate, build, and lead. The government's proactive policies such as the PLI schemes, defence indigenization drives, and a push for digital infrastructure contribute significantly.

In this context, the recent success of the Delhi Machine Tool Expo stands as a testament to India's grit, resilience, and determination. Despite being postponed by a day—causing disruption and logistical challenges—the event concluded on a high note, reflecting the unwavering spirit of the industry and its stakeholders.

The present issue offers insights into the Expo while also bringing you engaging stories and developments from across the manufacturing industry—curated especially for you, our valued readers. As always, we look forward to your thoughts and feedback to help us serve you better.

*A bird sitting on a tree is never afraid of the branch breaking, because its trust is not on the branch but on its own wings. Always believe in yourself.*

# Wide range of machines for your growing needs



Sprint – Turning Center  
Batliboi

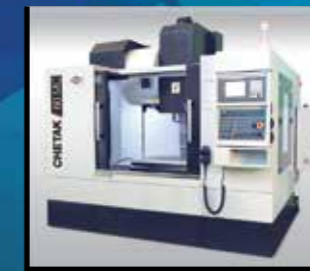

Chetak – Vertical Machining Center, Batliboi



VTL – Vertical Turning Lathe  
Batliboi



Annihilator – Gantry Machining Center  
Quickmill, Canada



CNC Horizontal Milling & Boring Machine  
SMT, Czech Republic



Plate Bending Machine  
DAVI-Promau, Italy



Cold Isostatic Press  
EPSI, Belgium



We manufacture as well as source leading brands of Machine Tools from around the world.

Our manufacturing facility at Surat turns out an impressive range of products – from conventional to sophisticated CNC machines.

Quickmill Inc., our Canadian subsidiary company, manufactures large area CNC Gantry and Bridge Milling and Drilling Machines at its manufacturing facility at Peterborough, Canada.

Agency Division of Batliboi represents state-of-the-art Metal Cutting, Metal Forming Machine Tools and Industrial Equipment manufactured by leading manufacturers from around the world. **We provide end-to-end solutions.**

Our quality consciousness assures dependable products, and our unrivalled pre-sales & post-sales services ensure total customer satisfaction.



**Batliboi Ltd.**  
Machine Tool Group

Bharat House, 5th Floor, 104 Bombay Samachar Marg, Fort, Mumbai – 400 001.  
Phone: +91.22.6637 8200 | Email: info@batliboi.com  
Web: www.batliboi.com

### Repair, Rewinding & Servicing of All types of Spindle Motors, Servo Motors & Torque Motors



Servo Motors



Rewinding of Servo Motors



Spindle Motor Winding Encapsulation



ChipIn Spindle



Belt Driven Spindle



Torque Motor Rewinding



Encapsulation of Torque Motor Winding

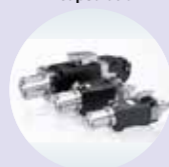

Hybrid Spindle



Milling Spindle



Torque Motors-Rotary Table Motors

India's Only Authorised Service Centre for



www.rajamanehegde.com

Bangalore - santoshpattar@rajamane.com  
Tumkur - rhp.tmk@rajamane.com  
Pune - rhp.pune@rajamane.com

Mobile No: 9900592261  
Mobile No: 9845511386  
Mobile No: 9900551455  
Mobile No: 8007819988



www.rhpui.com

## ECONOMY REFLECTS UPBEAT MARKET SENTIMENT

India's economy showed steady momentum in early 2025, with strong PMI figures, easing inflation, and a supportive policy stance. The machine tool industry recorded 5% production growth and 16% higher consumption, despite a decline in exports. Rising imports from China, Japan, and Germany highlight continued domestic demand and global engagement.

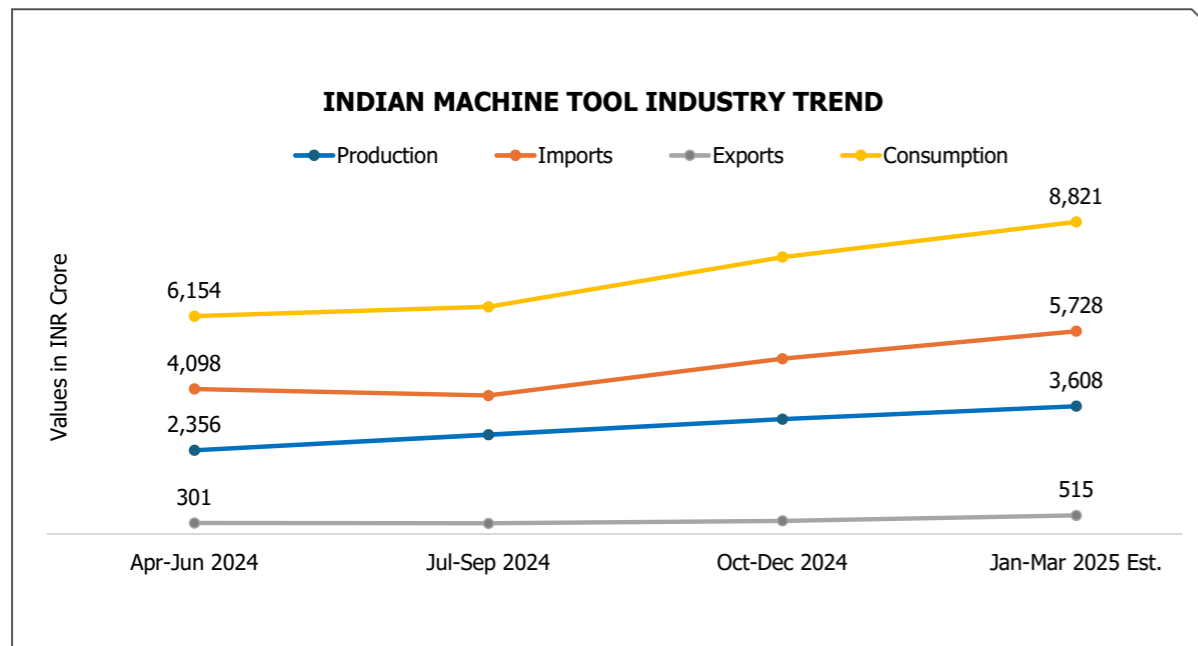

Table 1. Indian Machine Tool Industry Trend

**I**n March 2025, India's macroeconomic landscape exhibited promising signs, with manufacturing PMI (Purchasing Managers' Index) increased to an eight-month high of 58.1. Services PMI also continued to remain at a high level of 58.5. IIP (Index of Industrial Production) growth moderated to a six-month low of 2.9 percent in February 2025 due to a fall in the growth of manufacturing and mining output.

**Inflation Eases, RBI Adopts Growth-Friendly Stance**  
 Despite this momentum, the

Reserve Bank of India (RBI) reduced the repo rate by 25 basis point to 6.0 percent in its monetary policy review held on April 2025. It also changed the policy stance from 'neutral' to 'accommodative' in order to support growth. Meanwhile, CPI (Consumer Price Index) inflation eased to a 67-month low of 3.3 percent in March 2025, while WPI (Wholesale Price Index) inflation moderated to 2.0 percent in March 2025 from 2.4 percent in February 2025.

**Government Revenues Rise Despite Fiscal Pressures**  
 On the fiscal front, the Govern-

ment of India (GoI) witnessed a growth in gross tax revenues (GTR) by 10.9 percent during April-February FY25. However, fiscal and revenue deficits during April-February FY25 stood at 85.8 percent and 93.8 percent, respectively of their annual Revised Estimates (RE).

**Trade and Investment**  
 The banking sector witnessed a surge in gross bank credit by 12.0 percent in February 2025, marginally lower compared to 12.5 percent in January 2025, while the current account deficit narrowed to 1.1 percent of GDP

in 3QFY25 from 1.8 percent in 2QFY25. Merchandise trade deficit increased to US\$ 21.5 billion in March 2025 from US\$ 14.1 billion in February 2025, owing to a surge in oil and gold imports. Merchandise exports and imports turned positive at 0.7 percent and 11.4 percent, respectively, in March 2025 from a contraction of (-)10.9 percent and (-)16.3 percent, in February 2025. FDI (Foreign Direct Investment) and FPI (Foreign Portfolio Investment) witnessed outflows amounting to US\$ 1.2 billion and US\$ 4.0 billion respectively in February 2025, and global crude price fell to US\$ 70.7/bbl in March 2025, its lowest level since August 2021. The IMF (International Monetary Fund) has projected global growth at 2.8 percent in 2025, with India's FY26 growth forecasted at 6.2 percent.

### Machine Tool Industry: Consumption and Production Up, Imports Surge, Exports Down

The Indian Machine Tool industry's production in FY2024-25 is estimated to have increased by 5 percent to reach INR 14,286 crore (US\$ 1.7 B). The industry's imports in FY2024-25 saw a rise of 22 percent year-on-year, amounting to INR 18,686 crore (US\$ 2.2 B). Machine tool exports during FY2024-25 from India reported a -11 percent decline on a low base, amounting to INR 1,472 crore (US\$ 173 M) and consumption is estimated to have increased by 16 percent to reach INR 31,500 crore (US\$ 3.7 B) in FY2024-25. In FY2024-25, China (25%), Japan (19%), and Germany (12%) emerged as the top countries for imports to India, contributing to 56 percent of the total machine tools imports.

Presses (17%), Vertical Machining Centers (VMCs) (12%) and Lathes (10%) were the top machinery types imported, valued at INR 7,275 crore (US\$ 858 M), constituting approximately 39 percent of total machine tool imports during the period. On the export front, Russia (20%), the UAE (13%), and Saudi Arabia (10%) emerged as the major destinations, collectively representing 43 percent of total machine tool exports in FY2024-25 and amounting to a total export value of INR 1,472 crore (US\$ 173 M). Among the machinery types, Lathes (17%), Presses (14%) and VMCs (12%) stood out as the top three machinery types exported, with a combined value of INR 629 crore (US\$ 74 M), accounting for roughly 43 percent of total machine tool exports during FY2024-25.

**Machine Tool consumption is estimated to have increased by 16% to reach INR 31,500 crore (US\$ 3.7 B) and Imports to India saw a rise of 22% amounting to INR 18,686 crore (US\$ 2.2 B).**

**EMO HANNOVER**  
 22-26/09/2025

**Made for Metalworking**

Welcome to the world's leading trade fair for production technology.

**50** Years of Innovating Manufacturing

www.emo-hannover.com

Eine Messe des A Fair by VDW

# INDIA'S ROBOTIC REVOLUTION IN MANUFACTURING

Across the world's shop floors, a silent revolution is unfolding – one shaped not by clamour, but by code, cables, and precision. Industrial robots, once relegated to mundane lifting and shifting, have emerged as the sophisticated hands of modern manufacturing, performing everything from welding and painting to sealing and assembly with surgical finesse.



Source: Magic Wand Media

**W**hat began as a quest to shield humans from hazardous conditions has now evolved into a dynamic partnership – one where cobots (collaborative robots) work shoulder to shoulder with humans, enhancing safety, boosting productivity, and ushering in a new era of efficiency. In this unfolding industrial symphony, robotics and automation now form the rhythm section of Industry 4.0, demanding a new class of skilled maestros

– engineers who can program, integrate, and innovate.

### Global Cadence and India's Momentum

The global march of robotics has continued to accelerate. According to the World Robotics 2024 Report by the International Federation of Robotics, a remarkable 541,302 industrial robots were installed worldwide in 2023. Asia maintained dominance, accounting for around 70 percent

of new installations, followed by Europe at 17 percent and the Americas at 10 percent. China led the global tally with 276,288 units installed, representing over half of all global installations. Notably, India achieved a significant milestone, recording a 59 percent increase in robot installations, from 5,353 units in 2022 to 8,510 units in 2023, elevating its global ranking to seventh place. India's operational stock of industrial robots has nearly dou-

Source: IMTMA

# India's Leading International Machine Tools Exhibition

Concurrent Show  
**PPPEX 2026**  
 Plastics & Polymers Exhibition  
 2 - 6 APRIL 2026  
 Chennai Trade Centre, Chennai, India  
 MOULDS & DIES - PROCESS & RAW MATERIALS

**IMTOF 2026**  
 INTERNATIONAL MACHINE TOOL FAIR  
 2 - 6 April 2026  
 Chennai Trade Centre, Chennai, India

## Network with Experts in Machine Tools & Metal Forming



Organised by  
  
**MADRAS MACHINE TOOLS  
 MANUFACTURERS ASSOCIATION**

Title Sponsor  



Scan the QR to Visit Website

### HIGHLIGHTS

- ◆ 8 Modern RCC A/c Halls
- ◆ 60,000++ Business Visitors
- ◆ 30,000 sqm Exhibition Area
- ◆ **Plastics, Moulds & Dies Pavilion**
- ◆ Technical Sessions
- ◆ Product launches
- ◆ Live Demonstrations



Supported by



[www.imtof.in](http://www.imtof.in) | [info@imtof.in](mailto:info@imtof.in)

Chennai Trade Centre, Chennai, India

+91 - 72009 76882 / 81

According to the World Robotics 2024 Report by the International Federation of Robotics, India achieved a significant milestone, recording a 59% increase in robot installations, from 5,353 units in 2022 to 8,510 units in 2023, elevating its global ranking to seventh place.

bled since 2018, reaching 44,958 units in 2023, reflecting an average annual growth rate of 14 percent. The Automotive sector was a significant contributor to this surge, with installations soaring by 139 percent to 3,551 units, accounting for 42 percent of the market. Other industries, such as Rubber and Plastics, also demonstrated notable growth, while the Metal industry maintained steady adoption rates. This upward trajectory underscores India's growing prominence in the global robotics landscape, driven by robust economic growth and increased investments in automation across key sectors. Automation has occasionally stirred anxieties, such as in Bangladesh's labor-intensive Textile sector. Yet with every new wave of mechanization, not only are jobs reshaped, but entirely new ones are born, albeit demanding evolved skill sets and new avenues of human potential.

#### India's Vision and Road Ahead

India's embrace of robotics is

seen as both deliberate and visionary. The Government of India, through its IndiaAI Mission, aims to build a comprehensive ecosystem that fosters AI innovation by democratizing computing access, enhancing data quality, developing indigenous AI capabilities, attracting top AI talent, enabling industry collaboration, providing startup risk capital, ensuring socially impactful AI projects, and promoting ethical AI. Creating inclusive language models (Digital India Bhashini) or demystifying artificial intelligence for students (YUVAi) are byproducts of this initiative. The National Strategy on Robotics zeroes in on four sectors with transformative potential: Manufacturing, Healthcare, Agriculture, and National Security, setting the stage for India to emerge as a global robotics leader by 2030. Despite challenges such as high hardware costs, import dependencies, and R&D constraints, hope remains. Industry stalwarts like FANUC, ABB, KUKA, and YASKAWA are pioneering

India-made robots. As adoption grows, the very nature of Indian manufacturing is poised for reinvention, potentially establishing India as the world's alternate factory floor.

#### Symposium on Automation & Robotics

To further fuel this transformation, the Indian Machine Tool Manufacturers' Association (IMTMA) will present the eighth edition of the Symposium on Automation & Robotics from June 4 - 5, 2025, at Auto Cluster Exhibition Center, Pune. The symposium will explore precision and performance, collaborative robotics, convergence of AI, machine learning, and IoT in modern manufacturing and beyond. Thought leaders will illuminate paths forward through case studies and technical insights. The symposium also celebrates excellence, recognizing companies that exemplify automation-led performance. Participation promises more than knowledge – it offers a glimpse into the future of Indian manufacturing, one where machines and minds move in perfect harmony. 



## EPLAN Powering Precision in Machine Building

Elevate your machine-building journey with EPLAN's comprehensive solutions, seamlessly bridging the gap from engineering design to the production floor.

- **Precision in Planning and Design:** Master electrical engineering with EPLAN's innovative tools for schematic diagrams and system layouts.
- **Effortless Procurement:** Navigate component procurement seamlessly with EPLAN's integrated interfaces to streamline your supply chain.
- **Workshop Harmony:** Achieve operational synergy with deep integrations that synchronize your design processes with shopfloor operations.
- **Your Gateway to Efficiency:** Choose EPLAN for unmatched expertise, simplified procurement, and elevated production efficiency.

For further enquiries contact:

#### Eplan Software Private Limited

📍 Floor, Brigade Triumph, Dasarahalli Main Road, Sector B, Hebbal Kempapura, Bengaluru – 560092  
+91-80-61079100 | [www.eplan.in](http://www.eplan.in)

Ms. Pooja Narain +91 97311 57563 📧 [pooja.narain@eplan.in](mailto:pooja.narain@eplan.in)

READY TO  
REVOLUTIONIZE  
YOUR MACHINE  
BUILDING?



SCAN QR

**When Goals Matter!**

MODERN MANUFACTURING INDIA

For Advertising Contact:  
**MURALI SUNDARAM**  
E: [murali.sundaram@magicwandmedia.in](mailto:murali.sundaram@magicwandmedia.in) | M: +91 9740048390

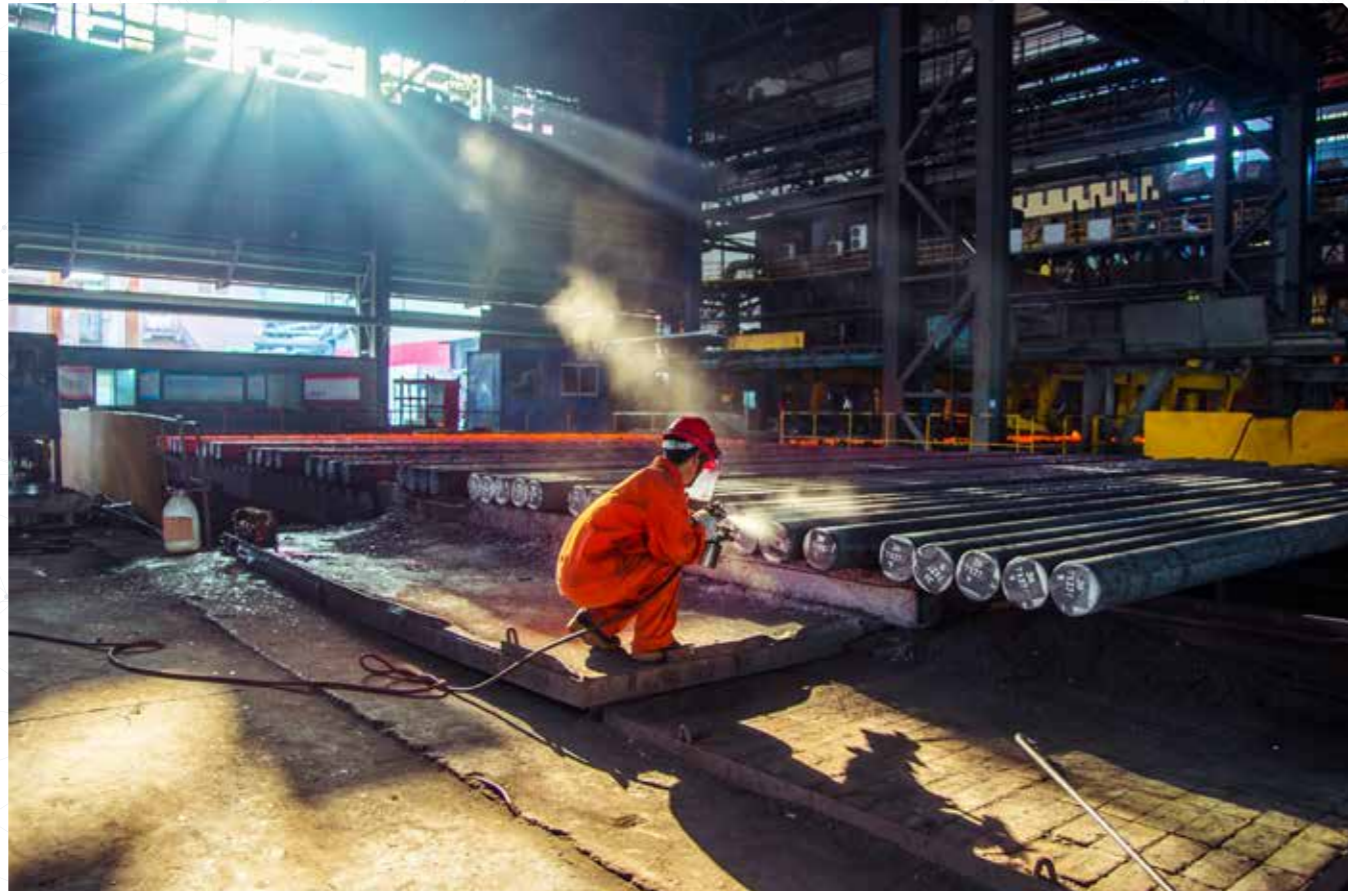

Jiangyin Xingcheng Special Steel Works Facility

Source: Magic Wand Media

## BREAKING THE IRON CEILING

In a groundbreaking development poised to redefine modern metallurgy, a team of scientists led by researchers in China has unveiled a new type of steel that is both ultra-strong and unusually stretchable.

According to the team, a piece of the steel the size of a fingernail can bear the weight of a 2-tonne car without fracturing, and the ductile metal can also be stretched by 18 to 25 percent. The scientists said the material would have applications in the Vehicle, Aerospace and Machinery sectors, where it could be formed into complex shapes and absorb high energy from the impact of a collision.

Creating ultra-tough steel that can also be extended has been a major challenge for scientists because strength and ductility are usually mutually exclusive. But there is industry demand for such a material for use in lightweight and safe

transport, construction and infrastructure. The team—from Northeastern University in Shenyang, Shenyang National Laboratory for Materials Science and Jiangyin Xingcheng Special Steel Works in eastern China, as well as the Max Planck Institute for Iron Research in Germany—published its findings in the peer-reviewed journal Science in 2023, but trials to scale the production of sheets of the material that demonstrate consistent mechanical properties across large sections are ongoing. The discovery centers on a novel alloy composition and microstructure that overcome one of the most persistent trade-offs in steel design. While

REJI VARGHESE  
President  
RV Forms & Gears  
fngrejji@gmail.com



India's Premier  
International  
Machine  
Tools Show

**ACMEE 2025**  
16<sup>th</sup> International Machine Tools Exhibition  
An AIEMA Initiative  
**19 - 23 June 2025**  
Chennai Trade Centre, Chennai, India

Title Sponsor



Concurrent Show  
**Artech 2025**  
AUTOMATION & ROBOTICS  
TECHNOLOGY SHOW 2025

INTERNATIONAL CONFERENCE ON  
AUTOMATION & ROBOTICS

June 2025

20 21



BEYOND SMART MANUFACTURING

June 2025

19 20 21 22 23

- 30,000 sqm of Exhibition Space
- 8 Modern RCC A/C Halls
- 500 plus Participants
- Meet the Global Industrial World Leaders in Machine Tools
- New Products, Technologies
- Product Launches
- Live Product Demonstrations
- Technical Sessions
- Finance Lounge
- Acclaimed Platform for Developing Business

### PLATINUM SPONSORS



### GOLD SPONSORS



### SILVER SPONSORS



### ASSOCIATE PARTNERS



VISITOR  
REGISTRATION



www.acmee.in

While conventional high-strength steels often suffer from brittleness—leading to catastrophic failure under stress—this new material retains tensile ductility even at ultra-high strengths exceeding 2 gigapascals (GPa).

conventional high-strength steels often suffer from brittleness—leading to catastrophic failure under stress—this new material retains tensile ductility even at ultra-high strengths exceeding 2 gigapascals (GPa).

**The Ductility Dilemma**

Steel's strength and ductility—its ability to stretch without breaking—are governed largely by its internal crystalline structure and how that structure responds to stress. Over the past century, metallurgists have devised numerous ways to manipulate these features through alloying elements and heat treatments. However, the strengthening mechanisms, such as precipitation hardening or grain refinement, tend to impede dislocation motion, a key driver of ductility.

“Achieving high strength usually means compromising on ductility,” said Dr Wang Haifeng, lead author of the study and a materials scientist at the University of Science and Technology Beijing. “We have developed a mechanism that defies this conventional wisdom.”

The team's solution lies in a clever orchestration of chemical composition and microstructural control. The new alloy is a complex, multiphase steel containing manganese (Mn), aluminum (Al), and carbon (C) in carefully tuned proportions. These elements interact to form a dual-phase microstructure comprising austenite and ferrite, two steel phases with vastly different mechanical

properties. The interface between them becomes a critical zone where stress is redistributed and managed dynamically during deformation.

**Scaling the Innovation**

Beyond the lab, one of the most compelling aspects of this discovery is its scalability. Unlike some exotic materials that rely on rare elements or prohibitively expensive processing, the components of this steel are relatively abundant and compatible with existing industrial workflows. The researchers emphasize that the alloy can be produced using conventional casting and rolling methods, making it a practical candidate for mass production.

The team has already conducted pilot-scale trials, producing sheets of the material that demonstrate consistent mechanical properties across large sections. The steel maintained a tensile strength above 2 GPa with elongation over 25 percent—a feat unmatched by most current commercial steels.

“This combination of properties is unprecedented,” said Dr Li Ming, a Steel industry consultant not affiliated with the study. “It could enable lighter, safer cars, more resilient infrastructure, and more efficient wind turbines—all without the need for radical changes in manufacturing.”

**Broad Applications, Deeper Implications**

The implications of this material breakthrough extend far beyond the laboratory. In automo-

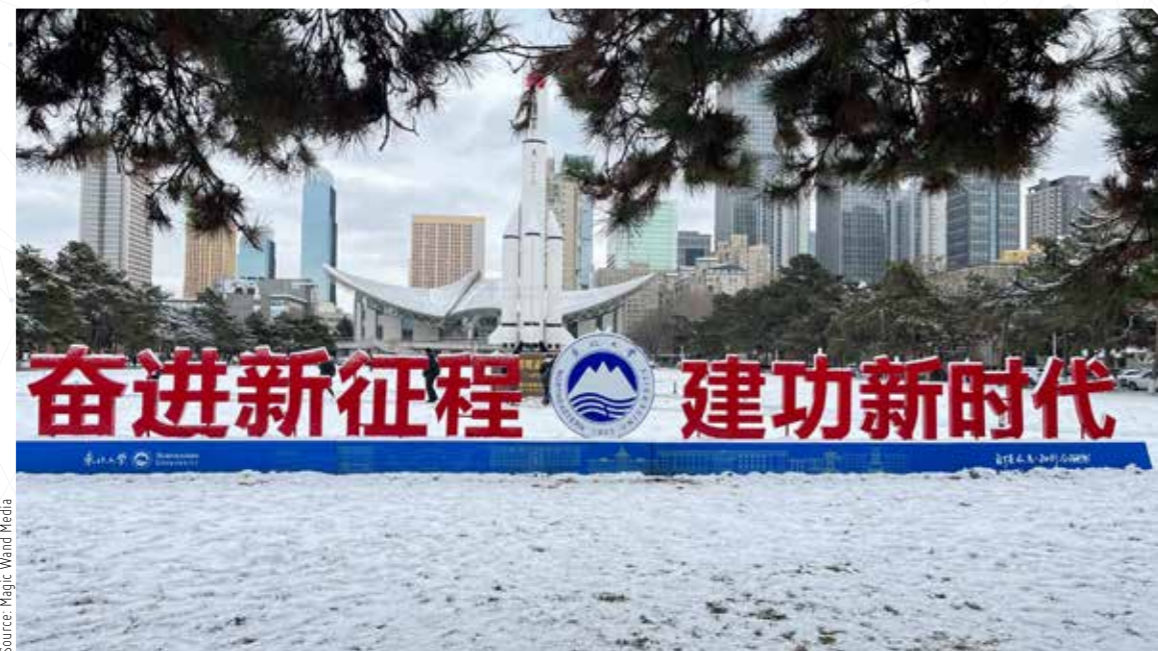

Source: Magic Wand Media  
Northeastern University in Shenyang



# Thermal Deburring

## T Series



Transmission



Fluid Power



Die Casting



## by Extrude Hone

Compact | Productive | Energy Efficient

Backed by decades of global experience in diverse industries, Extrude Hone offers not just a TEM machine, but a complete solution. In India, we combine the best of local resources with global expertise to offer the best to the industry.

### HELPING YOU TO PROGRESS SINCE 1960's



Website

Extrude Hone India Pvt. Ltd.

A-5, Jai Bharath Industrial Estate, Yeshwanthpur | Bangalore 560 022  
help@extrudehone.com | www.extrudehone.com



India Video

The new alloy is a complex, multi-phase steel containing manganese (Mn), aluminum (Al), and carbon (C) in carefully tuned proportions. They interact to form a dual-phase micro-structure comprising austenite and ferrite, two steel phases with vastly different mechanical properties.

“This combination of properties is unprecedented. It could enable lighter, safer cars, more resilient infrastructure, and more efficient wind turbines—all without the need for radical changes in manufacturing.”

**Dr Li Ming**  
Steel Industry Consultant

“Achieving high strength usually means compromising on ductility. We have developed a mechanism that defies this conventional wisdom.”

**Dr Wang Haifeng**  
Materials Scientist  
University of Science and Technology Beijing

tive design, manufacturers face constant pressure to reduce vehicle weight for fuel efficiency and electrification without compromising crash safety. A steel that is both strong and stretchable offers an elegant solution, allowing engineers to design thinner, lighter components that can still absorb impact forces effectively.

In aerospace, where every gram counts and materials must endure extreme mechanical and thermal stresses, the alloy's high performance could prove invaluable. Civil engineers could use it to construct earthquake-resistant buildings or longer-span bridges with fewer support columns. Even in consumer electronics, thinner and more durable chassis could become feasible.

More subtly, the innovation also advances fundamental materials science. By demonstrating that the strength-ductility trade-off can be circumvented through sophisticated microstructural engineering, the research opens new pathways in alloy design. It may inspire similar approaches in other metal systems like titanium, aluminum, and nickel-based superalloys.

#### Impact For the Machine Tool Industry

The advent of this ultra-strong yet stretchable steel could have significant implications for the Machine Tool industry, both as an opportunity and a technical challenge. Machine tools are the backbone of modern manufacturing, tasked with shaping and forming materials into precise components. The new steel's unique combination of high strength and ductility means that traditional machining, forming, and cutting processes may need to be reevaluated or upgraded to handle its

behavior under stress.

From a tooling perspective, the steel's high tensile strength (exceeding 2 GPa) will likely accelerate wear and tear on conventional cutting tools. Carbide and even some coated tools may struggle to maintain edge integrity over long production runs. This could drive increased demand for ultra-hard tool materials such as cubic boron nitride (CBN) and polycrystalline diamond (PCD), as well as next-generation coatings engineered for extreme hardness and heat resistance. Machine tool manufacturers will be under pressure to develop more robust spindles, higher-force forming systems, and improved thermal management strategies to accommodate the higher loads and friction this steel may generate during processing.

At the same time, the material's exceptional ductility opens up new possibilities for cold forming and high-speed stamping—processes that typically struggle with brittle high-strength steels. Manufacturers could achieve more complex geometries with fewer cracks and failures, reducing the need for multi-step processing or thermal treatments.

#### Towards the Future of Steel

Steel, in many ways, is the backbone of modern civilization. From the tallest skyscrapers to the smallest mechanical springs, its ubiquity is rivaled only by its versatility. But for all its utility, it has long been constrained by an inherent trade-off: strength versus ductility. This new discovery may finally provide a way to transcend that binary, offering a material that is not only tougher, but also more forgiving. 

*Tech Talks is a column by industry veteran and journalist Reji Varghese that talks about the latest advancements in Machine Tools, provides snippets from history, interesting facts, etc. about the Machine Tool industry.*

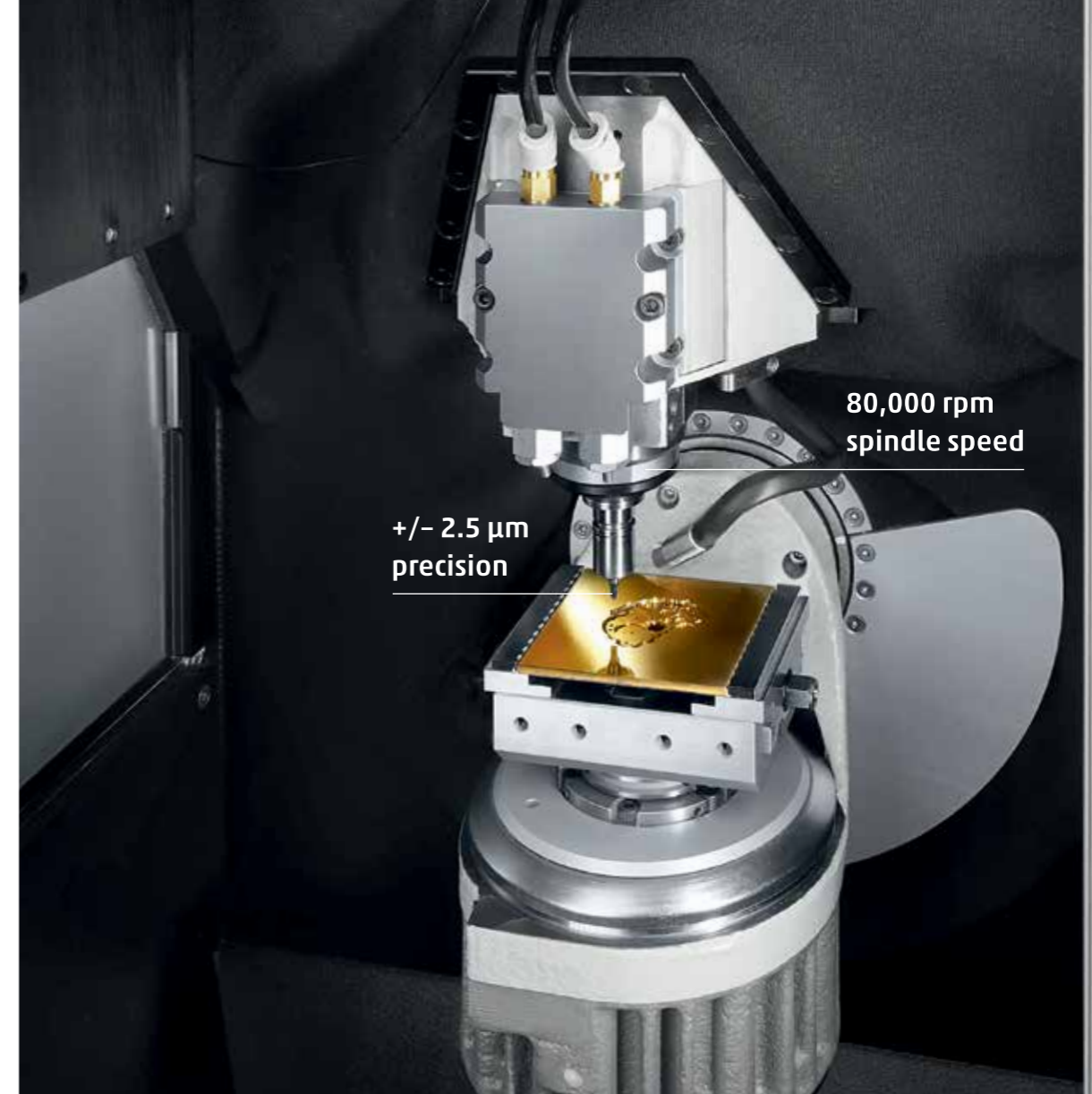

80,000 rpm  
spindle speed

+/- 2.5 µm  
precision

## Leading the future of micro-machining

Do you manufacture for medical devices, watchmaking, jewelry and small special parts? Whether you're after prototypes or larger production runs, and if you're seeking for ultra precision, sustainability and small footprint, all in one machine... well, the solution is our Micro5.



  
**CHIRON Group**

www.chiron-group.com

## CUTTING TOOLS MARKET: TRENDS, GROWTH DRIVERS, AND FUTURE OUTLOOK

As global industrialization accelerates and technological innovations redefine manufacturing processes, the cutting tools market is poised for substantial growth, driven by demand for advanced materials, automation, and enhanced productivity.



Source: Magix Wand Media

The global cutting tools market has emerged as a cornerstone in the manufacturing and industrial sectors, playing a vital role in shaping components for industries such as Automotive, Aerospace, Construction, Oil & Gas, and General Machinery. Cutting tools are essential for precise machining processes, enabling high-quality finishes and dimensional accuracy in metalworking, drilling, milling, and turning applications.

### Market Overview

According to a report on the cut-

ting tools market, the industry is expected to grow significantly in the coming years. The cutting tools market is broadly segmented by product type, material, application, and region. Based on product type, the market includes indexable inserts, solid round tools, and others such as tool holders and reamers. Among these, indexable inserts have gained significant traction due to their cost efficiency and adaptability for repetitive machining operations. Solid round tools are also in high demand for their rigidity and precision in complex geometries.

Material-wise, cutting tools are typically manufactured from high-speed steel (HSS), carbide, ceramic, cubic boron nitride (CBN), and polycrystalline diamond (PCD). Carbide-based tools dominate the market owing to their superior hardness, resistance to wear, and high-temperature performance. The rise of superalloys and composite materials, particularly in aerospace and defense applications, is further driving innovation in tool materials to accommodate harder and more complex workpieces.

MAYURI KATHADE  
Digital Marketing  
Analyst  
Market Research  
Future (MRFR)



# High Precision Spindles Total Solutions



Belt-Drive Spindle - Milling



Direct-Drive Spindle



Motorized Spindle - Multi-Spindle



Motorized Spindle - Milling (40000 rpm)



Motorized Spindle - Milling



Belt-Drive Spindle - Turning



Motorized Spindle - Turning

**ROYAL** High Precision / High Stability / High Rigidity / High Efficiency

ROYAL PRECISION TOOLS CORPORATION

No. 21, Sec. 1, Zhongshan Rd., Wuri Dist., Taichung City 414, Taiwan

TEL: +886 4 2338 2068

FAX: +886 4 2335 9945

Email: royal\_sa@royal-spindles.com.tw

www.royal-spindles.com

APAC remains the largest and fastest-growing market for cutting tools, driven by rapid industrialization, favorable government policies, and robust automotive and electronics sectors. China, in particular, stands out as both a major producer and consumer of cutting tools due to its massive manufacturing base.

### Growth Drivers

One of the primary drivers of the cutting tools market is the resurgence of the Automotive industry. With the growing demand for electric vehicles (EVs), hybrid models, and fuel-efficient internal combustion engines, there is an increased need for precise and efficient machining of engine components, transmission parts, and structural elements. Lightweight materials like aluminum and carbon fiber composites necessitate specialized cutting tools capable of maintaining integrity and quality under high-speed machining conditions.

Another significant driver is the rapid advancement of Industry 4.0 technologies. Smart manufacturing, powered by the Industrial Internet of Things (IIoT), artificial intelligence (AI), and machine learning (ML), is leading to the integration of sensor-based cutting tools that provide real-time data on wear and performance. Predictive maintenance and adaptive machining are becoming standard in modern workshops, which demand tools that are not only durable but also intelligent. This evolution is transforming traditional cutting tools into critical components of digital manufacturing ecosystems.

In addition, the global shift to-

wards renewable energy and infrastructure development is bolstering demand for cutting tools. Wind turbines, solar panel components, and energy-efficient systems all require precision machining. The construction boom in emerging economies like India, China, and Southeast Asia is further accelerating demand for heavy machinery and construction equipment, fueling the consumption of durable and high-performance cutting tools.

### Regional Insights

Asia-Pacific (APAC) remains the largest and fastest-growing market for cutting tools, driven by rapid industrialization, favorable government policies, and robust Automotive and Electronics sectors. China, in particular, stands out as both a major producer and consumer of cutting tools due to its massive manufacturing base. Japan and South Korea also contribute significantly with their advanced technological capabilities and emphasis on precision engineering.

North America follows as a key market, with the United States being a hub for aerospace and defense manufacturing. The country's commitment to reshoring manufacturing activities and investment in advanced machining

technologies continues to create growth opportunities for cutting tool manufacturers. Europe, led by Germany, Italy, and France, also holds a substantial market share, supported by strong automotive production and a well-established industrial base.

The Middle East and Africa (MEA) region is expected to witness steady growth, particularly in oil & gas exploration, construction, and mining activities. Latin America, though relatively smaller in market size, is showing promise with increasing investment in infrastructure and industrial equipment.

### Technological Innovation

Technological innovation remains at the heart of cutting tool development. Coatings such as titanium aluminum nitride (TiAlN), diamond-like carbon (DLC), and multilayer coatings are significantly enhancing tool life and performance. These coatings improve resistance to heat, corrosion, and abrasion, allowing tools to operate at higher cutting speeds and for longer durations without degradation.

Additive manufacturing (3D printing) is also beginning to influence the design and production of cutting tools. Customization and complexity in tool geometries, once limited by traditional manufacturing methods, are now achievable with 3D printing, enabling manufacturers to produce optimized, application-specific tools with internal cooling channels and lightweight structures.

Furthermore, tool monitoring systems are being integrated with computer numerical control (CNC) machines to track tool usage, wear patterns, and temperature in real time. This data-driven approach helps in reducing tool failure, enhancing productivity, and minimizing downtime, which is crucial in high-volume production environments.



Source: Magic Wand Media

WE HAVE RAISED

THE BAR OF QUALITY



### MARPOSS ULTRA PROBING SYSTEM

-  No interference
-  Ultra-compact dimensions
-  Extreme watertightness
-  User friendly APP
-  Easy to use



**MARPOSS**  
www.marposs.com

Looking ahead, the cutting tools market is set to grow at a steady CAGR, with projections indicating a market value exceeding US\$ 40 billion by the end of the decade. Sustainability, digitalization, and customization will be the key pillars shaping the future of the industry.



Source: Magic Wand Media

### Competitive Landscape

The cutting tools market is highly competitive and fragmented, with several key players and a large number of regional manufacturers. Leading companies such as Sandvik AB, Kennametal Inc., Mitsubishi Materials Corporation, ISCAR Ltd. (IMC Group), and Sumitomo Electric Industries Ltd. dominate the global landscape through extensive R&D, strategic acquisitions, and global distribution networks. These companies continuously invest in innovation to expand their product portfolios and cater to evolving customer requirements. Collaborative efforts with end-users for customized solutions, along with a focus on sustainability and recycling of tool materials, are emerging trends in competitive strategy. Startups and niche players are also gaining ground by offering specialized products and leveraging digital platforms to reach broader customer bases. The trend towards e-commerce in industrial tools is disrupting traditional distribution models, mak-

ing it easier for smaller players to compete on a global scale.

### Challenges and Opportunities

Despite its promising growth, the cutting tools market faces certain challenges. Fluctuations in raw material prices, particularly tungsten and cobalt, impact production costs. Additionally, the growing emphasis on sustainability and environmental regulations may pose compliance challenges, especially for manufacturers using non-renewable resources. Another hurdle is the skills gap in precision machining. As cutting tools become more advanced, the demand for skilled operators and engineers who can effectively use and maintain these tools is rising. Bridging this talent gap through training and education is crucial for industry growth. Nevertheless, the opportunities outweigh the challenges. The ongoing digital transformation, coupled with increasing demand for high-speed, high-precision machining, offers immense potential for growth and innovation. The expanding scope of applications—

from micro machining in electronics to heavy-duty operations in shipbuilding—ensures a steady demand for diverse cutting tools tailored to specific needs.

### Future Outlook

Looking ahead, the cutting tools market is set to grow at a steady compound annual growth rate (CAGR), with projections indicating a market value exceeding US\$ 40 billion by the end of the decade. Sustainability, digitalization, and customization will be the key pillars shaping the future of the industry. Manufacturers that embrace advanced technologies, prioritize energy efficiency, and maintain agile supply chains will be well-positioned to lead the next wave of industrial evolution. As end-users across sectors seek faster turnaround times, improved surface finishes, and cost-efficient solutions, the cutting tools market will continue to evolve, offering smarter, stronger, and more sustainable tools to meet the dynamic needs of modern manufacturing. 

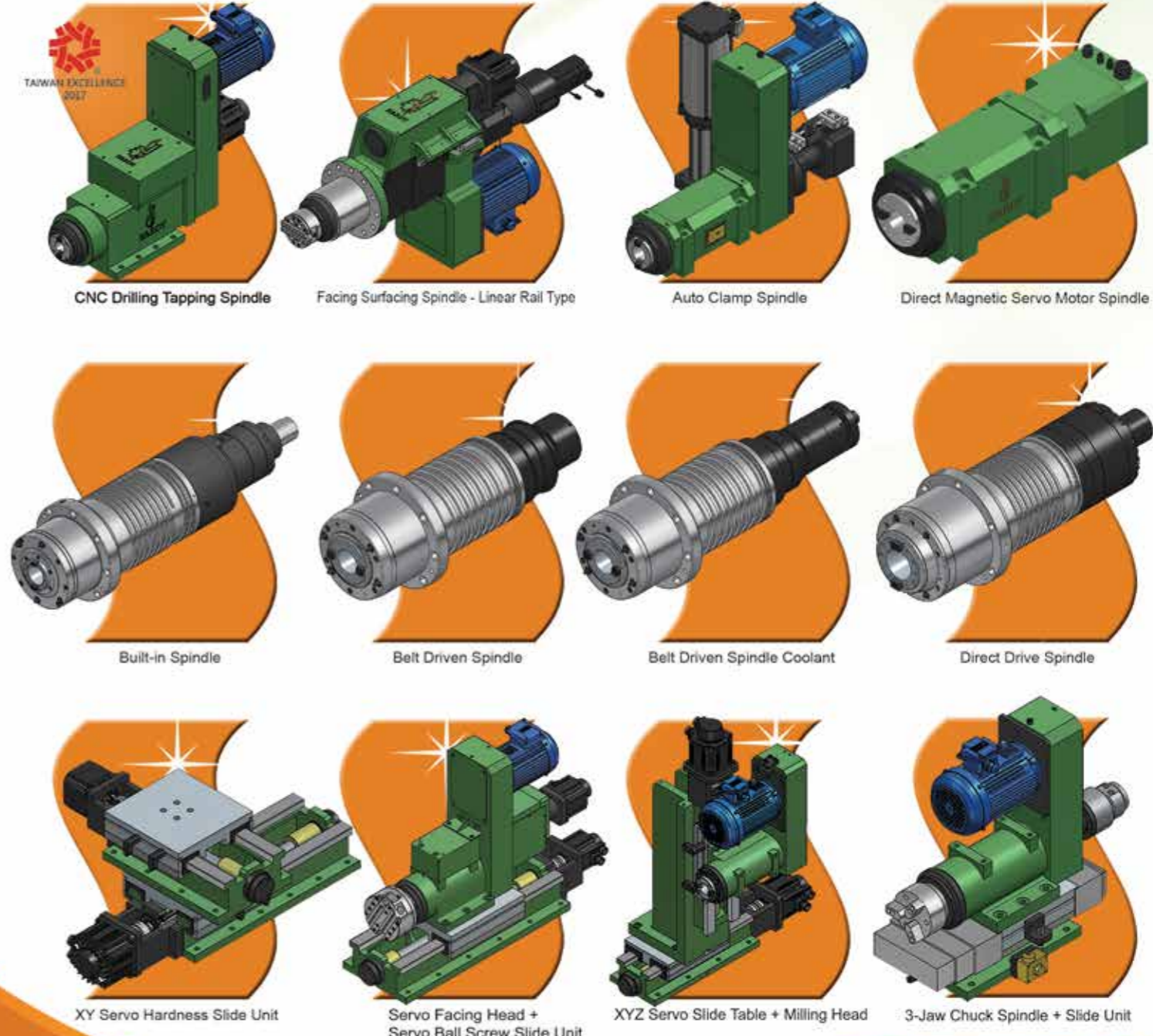

**HANN KUEN MACHINERY & HARDWARE CO., LTD.**  
 NO. 22, Liou Shun Rd., East District, Taichung City 401, Taiwan  
 TEL: +886-4-2486-0602 FAX: +886-4-2486-0605  
 E-mail: hann.kuen@hardy.com.tw  
<https://www.hardy-tw.com> Skype: hann.kuen



# HYBRID MANUFACTURING The Next Industrial Revolution



SUMIT Y WAGHMARE  
Chief Technology Officer  
ACE Designers Ltd



Hybrid manufacturing represents the perfect union between established machining expertise and cutting-edge additive technology, enabling components previously deemed impossible to manufacture. Here's an insight into the emerging technology poised to revolutionize production across multiple sectors...

In an industrial landscape where competition grows fiercer by the day, Indian manufacturers face increasing pressure to reduce costs while simultaneously enhancing quality and managing complexity. The answer may lie in an emerging technology that combines the precision of traditional machining with the transformative capabilities of additive manufacturing.

### The Power of Combination: Understanding Hybrid Manufacturing

At its core, hybrid manufacturing integrates additive manufacturing processes, specifically Wire Arc Additive Manufacturing (WAAM), with traditional CNC machining. This integration creates a manufacturing ecosystem where metal components can be built layer by layer through controlled welding processes and then precision-finished using conventional machining techniques. The approach leverages the best of both worlds: additive manufacturing's ability to create complex geometries with minimal material waste, combined with the di-

mensional accuracy and superior surface finish that only traditional machining can provide. The result is a manufacturing process particularly suited for high-value, complex components in industries ranging from Aerospace to Die & Mold production. For Indian manufacturers already equipped with CNC machines, the transition to hybrid manufacturing can be remarkably straightforward. The typical setup involves integrating a welding system, complete with power source and wire feeder, onto an existing 3+ axis CNC machine. This relatively modest investment can dramatically expand production capabilities.

### Economic Benefits: The Numbers Behind the Revolution Start Small: The Bootstrap WAAM Approach

Unlike laser-based metal printers costing crores of rupees, WAAM can use existing welding gear. A bootstrap setup might include:

- A second-hand 6-axis industrial robot
- A standard MIG/MAG or TIG welder

- Simple integration and programming.

This can be done in the range of INR 6-9 lakh, making it feasible for startups or MSMEs to begin exploring hybrid manufacturing with minimal risk. With low-cost wire feedstock and high deposition rates, WAAM makes large part production faster and cheaper. AceMicromatic's model aligns with this approach, supporting businesses to start small and scale up.

### Compelling argument for hybrid manufacturing

The economic argument for hybrid manufacturing becomes particularly compelling when working with expensive materials. While the cost-benefit analysis may be less dramatic with common structural steels (approximately INR 200/kg), the savings become significant with specialty materials. For example, in aerospace applications using titanium alloys like Ti-6Al-4V (approximately INR 8,000/kg), studies demonstrate cost reductions exceeding 60 percent compared to tradi-

Necessity is the mother of innovation. The current limitations of WAAM are paving the path for groundbreaking advances in hybrid manufacturing.

## Tool Path Generation Repair/Reclaim Hybrid – AM Workflow

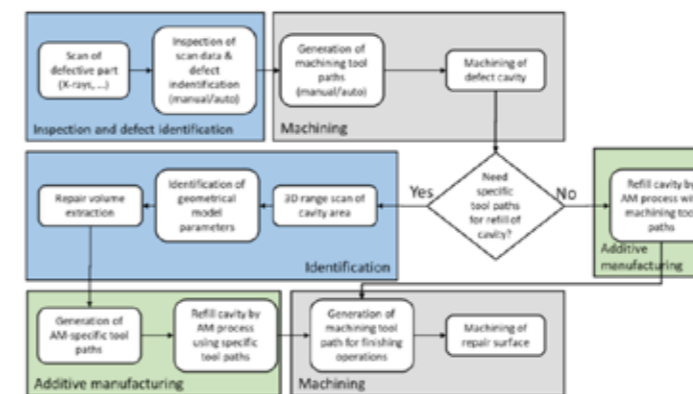

Source: AceMicromatic Group

Process Flow Diagram: Visual representation of the hybrid manufacturing workflow showing the integration of WAAM and CNC machining processes. (Reference slide on 'Repair/Reclaim Hybrid – AM Workflow')

## Experience Application Know-how



Application Development at ACE: Various applications are getting developed at ACE to establish the hybrid - WAAM process.

Source: AceMicromatic Group

Despite its promise, hybrid manufacturing faces several technical challenges, including poor surface finish, dimensional inaccuracy, residual stresses, and thermal management issues.

tional manufacturing methods. This saving stems primarily from dramatic reductions in material waste, hybrid methods can decrease material consumption by up to 48 percent compared to conventional milling. For small and medium enterprises (SMEs) in India's Manufacturing sector, hybrid manufacturing offers another critical advantage: the ability to produce small-batch, high-complexity components economically. Rather than relying on expensive casting processes for limited production runs, manufacturers can produce components with equivalent or superior mechanical characteristics in less time and at lower cost.

### Technical Innovations: Overcoming Hybrid Manufacturing Challenges

Despite its promise, hybrid manufacturing faces several technical challenges that Indian manufacturers must address to maximize benefits. The most significant of these include poor surface finish, dimensional inaccuracy, residual stresses, and thermal management issues. Recent research conducted at the Indian Institute of Technology,

Guwahati has made significant progress in addressing these limitations. Advanced cooling techniques have demonstrated particular promise, with in-situ cooling systems showing temperature reductions of up to 59 percent during the manufacturing process. This cooling not only improves dimensional stability but also enhances material properties. Process optimization represents another frontier of innovation. Advanced welding techniques like Pulse MIG welding (GMAW-P) and Cold Metal Transfer Advance Technology (CMT) have dramatically reduced heat input during deposition, in some cases by as much as 90 percent compared to conventional MIG/MAG processes. This reduction minimizes thermal distortion while improving weld quality and reducing spatter. Necessity is the mother of innovation. The current limitations of WAAM are paving the path for groundbreaking advances in hybrid manufacturing.

### Real-World Applications: From Impellers to Rocket Engines

The versatility of hybrid manufacturing is perhaps best illus-

trated through its diverse applications. In the Power Generation sector, WAAM technology has revolutionized impeller reconditioning and manufacturing. Rather than machining entire impellers from solid cylindrical workpieces, a process that generates excessive waste, manufacturers can now build up the complex geometry through additive processes and then finish-machine only where necessary. Even more dramatically, aerospace applications have demonstrated the technology's transformative potential. NASA has successfully employed 3D printing techniques to produce rocket engine components for its Artemis exploration mission. According to NASA officials, "This technology advancement is significant as it allows us to produce the most difficult and expensive rocket engine parts for a lower price tag than in the past." In India's growing Medical Device Manufacturing sector, hybrid manufacturing enables the production of customized implants and surgical tools with complex internal structures that would be impossible to create through traditional manufacturing methods alone.

## Key Statistics and Definitions

**WAAM (Wire Arc Additive Manufacturing):** A directed energy deposition method using electric arc to melt metal wire feedstock for layer-by-layer fabrication.

**Surface Quality Improvement:** Hybrid processes can enhance surface roughness by up to tenfold through layer-by-layer hybridization.

**Material Efficiency:** Reduction in material consumption by up to 48% compared to traditional milling.

**Cost Reduction:** For titanium aerospace components, cost reductions can exceed 60% compared to conventional manufacturing methods.

**Hardness Comparison:** Stellite deposits on P-20 Steel achieved 44-47 HRC (as welded) compared to base material hardness of 33 HRC.

### The Path Forward: Emerging Trends and Opportunities

For Indian machine tool manufacturers and users looking to capitalize on this technology, several emerging trends deserve attention. Advanced process monitoring and control systems are increasingly incorporating machine learning algorithms to optimize deposition parameters in real time. Multi-material manufacturing capabilities are expanding, allowing for gradient materials with varying properties within a single component. Perhaps most significantly for

India's manufacturing ecosystem, standardization and certification processes are evolving rapidly. As these standards become established, they will provide the regulatory framework necessary for wider adoption of hybrid manufacturing in critical applications.

The integration of specialized CAD/CAM software represents another crucial development area. Current software solutions often treat additive and subtractive processes separately, creating workflow inefficiencies. The development of integrated solutions specifically designed for hy-

brid manufacturing workflows presents a significant opportunity for software developers serving India's Manufacturing sector.

### Conclusion: Positioning for the Future

As global manufacturing trends increasingly favor high-mix, low-volume production with greater complexity, hybrid manufacturing positions Indian manufacturers to compete effectively in high-value market segments. By addressing current limitations through continued innovation in process control, thermal management, and integrated software solutions, India's Manufacturing sector can leverage this technology to reduce costs, minimize material waste, and expand production capabilities. For forward-thinking machine tool manufacturers and users, the message is clear: hybrid manufacturing represents not merely an incremental improvement but a fundamental shift in production capabilities, one that merges the precision of India's established machining expertise with the limitless potential of additive manufacturing. 

As global manufacturing trends increasingly favor high-mix, low-volume production with greater complexity, hybrid manufacturing positions Indian manufacturers to compete effectively in high-value market segments.

## Die-Reclamation



Source: AceMicromatic Group

Before/After Images: Photographs showing a component after deposition and after machining to illustrate the transformation from rough WAAM output to precision-finished part. (Reference 'Die-Reclamation' images)

# POWERING INDIGENOUS DEFENCE CAPABILITIES

Amit Mahajan, Director, Paras Defence & Space Technologies Ltd, in this insightful interview with MMI's Editor-in-Chief, Soumi Mitra, sheds light on the company's core strengths and its role in advancing India's indigenous defence manufacturing capabilities. He also shares the goal of being a leading hardware technology enabler to support the armed forces in this evolving era of hybrid warfare.

**Paras Defence specializes in advanced Optronic Systems for Defence and Space, Defence Electronics, Electromagnetic Protection Solutions, and Heavy Engineering. Could you elaborate on the company's core strengths across these domains for our readers?**

Paras Defence's operations are anchored in two core verticals optics and optronic systems and defence engineering—which include defence electronics, electromagnetic pulse (EMP) protection solutions, and heavy engineering. We are the only Indian company manufacturing optronic periscopes in the Asia-Pacific region for submarine applications, enabled by all-round capabilities in optics design & manufacturing and electronics & mechanical system engineering for Naval applications. Our technological footprint spans rockets, missiles, naval platforms, armoured systems, ISR (Intelligence, surveillance and reconnaissance) and space applications. In optics, we offer day/night sights, EO (electro optical) systems, and imaging payloads for unmanned aerial vehicle (UAVs) and satellites.

Under Defence electronics, our portfolio covers high-performance embedded computing and ruggedized electronics for missiles and electronic war-



**Amit Mahajan, Director, Paras Defence & Space Technologies Ltd**

fare (EW) platforms. Our EMP vertical ensures secure operations via shielding, TEMPEST systems which are used to prevent electronic eavesdropping, and Faraday enclosures that are

designed to block electromagnetic fields.

Through our group entities, we are expanding into next-gen domains. Paras Anti-Drone develops integrated counter-drone

systems and specializes in radio frequency (RF) and microwave technologies and Quantico Technologies intend to develop solutions in Quantum Communication & Quantum Sensing. Paras, in partnership with Israel's CONTROP, manufactures EO/IR gimbals. It recently launched a new line of indigenously built drone cameras for military and paramilitary use. Our JV with Israel's HevenDrones is aimed at co-developing heavy-lift autonomous drones, including hydrogen-powered platforms for long-range missions. These partnerships combine indigenous R&D with global tech to reinforce our position as a full-spectrum player in India's defence and space ecosystem.

**You're the only Indian manufacturer of optronic periscopes in the Asia-Pacific region. How did you build this unique capability, and how do you maintain the technological edge?**

India has long relied on foreign suppliers for critical defence technologies, including submarine periscopes, which are essential for underwater surveillance and situational awareness. Recognizing the strategic imperative of self-reliance, Paras Defence has committed itself to developing indigenous solutions to reduce this dependency.

In 2022, the Defence Research and Development Organisation (DRDO), through its Instrument Research & Development Establishment (IRDE), transferred the technology for optronic submarine periscopes to Paras Defence via a licensing agreement. This transfer marked a significant milestone, positioning Paras Defence as the first Indian company to manufacture these sophisticated systems on a turnkey basis.

**"Paras Defence is deeply aligned with the goals of 'Atmanirbhar Bharat' in defence. Over 75 percent of our product value chain is indigenous. We have successfully replaced many imported systems with Indian alternatives—be it electro-optical sights, control electronics for missile launchers, or electromagnetic interference (EMI) shielded systems for C4I applications. Our partnerships with DRDO, DPSUs and private OEMs help scale indigenous systems across platforms."**

**Amit Mahajan  
Director  
Paras Defence &  
Space Technologies Ltd**

Building on our extensive experience in defence electronics and optics, Paras Defence has successfully integrated advanced sensor technologies, image processing units and human-machine interfaces to develop state-of-the-art optronic periscope systems. These systems are designed to meet the stringent requirements of modern naval operations, enhancing the stealth and operational effectiveness of Indian submarines. This achievement underscores Paras Defence's commitment to import substitution and its role in advancing India's indigenous defence manufacturing capabilities.

**Can you shed light on how your in-house R&D ecosystem drives product innovation across such diverse domains—from missile systems to thermal space solutions?**

At Paras Defence, in-house R&D is the nucleus of our innovation journey and the foundation of our ability to deliver strategic technologies across defence and space. Our R&D ecosystem is collaborative and interdisciplinary, bringing together experts in optics, electronics, embedded systems, mechanical engineering and material sciences to co-develop cross-platform solutions.

We have made substantial investments in simulation tools, prototyping labs, and specialized testbeds, enabling rapid iteration from concept to deployment. This allows us to engineer high-reliability systems for applications ranging from missile-borne rugged electronics, control systems, and telemetry to EO payloads for UAVs and thermal shielding structures for satellites.

Our research spans both current requirements and emerging threats. In fast-evolving domains like electronic warfare, drones, and anti-drone systems, indigenous R&D is not just a differentiator, but a strategic necessity. We are actively developing jamming-resistant UAV platforms, miniaturized EW systems, image fusion algorithms, adaptive counter-drone technologies and radiation-hardened electronics for multi-domain use.

We also work closely with agencies like DRDO, Indian Space Research Organisation (ISRO), and the Society for Applied Microwave Electronics Engineering and Research (SAM-EEER) and collaborate with the private sector primes on national programmes to co-develop subsystems. By controlling the entire innovation cycle—from design and simulation to manufacturing and field-testing—we ensure our solutions are cutting-edge, scalable, and

**'Operation Sindoor' highlighted India's growing defence manufacturing strengths with successes like the Akashteer air defence system achieving a 100 percent intercept rate and effective use of indigenous drones such as SkyStriker and Nagas-tra. These milestones showcase the impact of 'Make in India'.**

SOUMI MITRA  
Editor-in-Chief  
Modern Manufacturing  
India  
soumi.mitra@  
magicwandmedia.in



**Since 2019, the evolution of Foreign Direct Investment (FDI) norms has created a conducive environment for indigenous development by encouraging technology transfers, joint ventures, and greater capital inflows. This policy shift lays the foundation for rapid growth and innovation in the defence sector.**

mission-ready for India's defence needs.

**Please elaborate on how Paras Defence contributes to India's push for defence indigenization, and what more needs to be done to accelerate this mission?**

Paras Defence is deeply aligned with the goals of 'Atmanirbhar Bharat' in defence. Over 75 percent of our product value chain is indigenous. We have successfully replaced many imported systems with Indian alternatives—be it electro-optical sights, control electronics for missile launchers, or electromagnetic interference (EMI) shielded systems for C4I applications. Our partnerships with DRDO, DPSUs and private OEMs help scale indigenous systems across platforms.

However, accelerating this mission further requires stable long-term procurement pipelines, increased R&D grants for private sector innovation, and the swift implementation of Indigenously Designed, Developed, and Manufactured (IDDM) category contracts. A unified technology roadmap led by the Ministry of Defence (MoD) and DRDO, with the private industry as a co-developer not just a supplier can further propel self-reliance. Another enabler is the creation of shared testing infrastructure for advanced domains like optics, hypersonics, and directed energy. India's talent and capacity, aligned with sustained investment, will unlock the full potential of indigenization.

**Paras Defence has recently announced developing the critical magnets for India's first indigenous Magnetic Resonance Imaging (MRI) machine as part of a consortium spearheaded by SAMEER an autonomous R&D institution under the Ministry**

**of Electronics and Information Technology (MeitY). What makes this a technological and strategic breakthrough for the country?**

The development of critical magnets for India's first indigenous MRI machine marks a pivotal moment for the country's strategic technology ecosystem. Paras Defence is proud to be a part of this national consortium led by SAMEER under MeitY. MRI systems are heavily import-dependent, particularly for high-performance superconducting magnets, which ac-

count for a major share of the machine's cost and complexity. By developing these magnets indigenously, we are tackling one of the most advanced engineering challenges in medical technology, bringing India closer to self-reliance in high-end diagnostic equipment. While the 'Make in India' initiative has driven assembly and local value addition, the real benefits of scale, cost competitiveness, and security of supply come only with complete indigenization of core technologies. That's where this project stands



Source: Paras Defence & Space Technologies Ltd

**"The development of critical magnets for India's first indigenous MRI machine marks a pivotal moment for the country's strategic technology ecosystem. Paras Defence is proud to be a part of this national consortium led by SAMEER under MeitY. MRI systems are heavily import-dependent, particularly for high-performance superconducting magnets, which account for a major share of the machine's cost and complexity."**

**Amit Mahajan  
Director  
Paras Defence & Space Technologies Ltd**



Source: Paras Defence & Space Technologies Ltd

apart. For Paras Defence, this opportunity leverages our deep expertise in electromagnetics, precision manufacturing, and cryogenic-compatible engineering. Strategically, this programme opens the door for India to create an indigenous supply chain for high-field magnets, applicable not just in healthcare but also in defence, research, and aerospace. It exemplifies how public-private collaboration can solve critical technology gaps and build long-term national capability.

**How would you assess India's current level of preparedness in defence manufacturing, especially in light of evolving global security challenges?**

'Operation Sindoor' highlighted India's growing defence manufacturing strengths with successes like the Akashteer air defence system achieving a 100 percent intercept rate and effective use of indigenous drones such as SkyStriker and Nagastra. These milestones showcase the impact of 'Make in India,' reducing import dependence and boosting self-reliance. The government's emergency procurement powers of ₹40,000 crore further enhance immediate defence

readiness, although this is a short-term measure.

India has made commendable strides but is in a transitional phase. Indigenous capabilities span missiles, radars, UAVs and naval platforms, yet full-system integration and export-grade standardization require more focus. The private sector's role has expanded under (defence acquisition procedure) DAP reforms, Defence Space and Drone policies, and iDEX initiatives.

Defence preparedness today must go beyond indigenization to include agility, adaptability and deterrence readiness. Emerging threats, from border skirmishes to grey-zone warfare, demand faster induction cycles, modular technologies and resilient supply chains. Paras Defence contributes by delivering high-reliability subsystems that enhance operational self-sufficiency. Our goal is to be a leading hardware technology enabler supporting the armed forces in this evolving era of hybrid warfare.

**How do you view the prospective growth of India's defence manufacturing ecosystem over the next 5-10 years?**

India's defence manufacturing ecosystem is set for robust growth over the next 5-10

years, driven by increasing government emphasis on self-reliance and strategic autonomy. Since 2019, the evolution of Foreign Direct Investment (FDI) norms has created a conducive environment for indigenous development by encouraging technology transfers, joint ventures, and greater capital inflows. This policy shift lays the foundation for rapid growth and innovation in the defence sector.

The private sector's expanding role, supported by DAP reforms and initiatives like iDEX and the Defence Space and Drone policies, is accelerating capabilities across design, development, and production. In response to complex global security dynamics, the ecosystem must emphasise agility, modularity, and scalable solutions. At Paras Defence, we focus on delivering high-reliability subsystems and platforms that meet the evolving demands of modern warfare. Strengthened industry, government partnerships, and resilient supply chains will enable India to emerge as a global defence manufacturing hub, capable of fulfilling both domestic requirements as well as export-grade standards. 

**Paras Defence contributes by delivering high-reliability subsystems that enhance operational self-sufficiency. Its goal is to be a leading hardware technology enabler supporting the armed forces in this evolving era of hybrid warfare.**



The finished parts: shown after production on the left and gold-plated on the right. Also pictured: the Torx Z7PL for scale.

Source: Horn/ANNEA

## RELIABLE MICRO-MACHINING IN LARGE-SCALE PRODUCTION

Swiss precision manufacturing company, Aeschlimann AG, improved the reliability and quality of micro-machining for high-volume production by using specialized cutting tools from HORN, distributed in India by NN Combined Engineering Agencies Pvt Ltd (NNEA).

“22,500 recesses with a diameter of 0.7 mm (0.028”) – this is when we need a special insert,” explains Michael Diethelm. Diethelm is a machine operator at Aeschlimann AG in Lüsslingen, Switzerland. Since the process optimization, the team – headed up by process expert Fabian Stampfli – has used HORN’s S274 grooving system for the profile grooving of an electronic component. “HORN is known for its solutions for micro-com-

ponent machining. This special insert with a precision-ground profile is yet another example of an exceptional product from our friends in Germany – and here in Switzerland, we are very satisfied with it,” says Dominik Läng, Turning Technology Product Manager at HORN’s Swiss partner Dihawag. From micro-sized watch components to parts for the Medical sector and excavator hydraulics, Aeschlimann AG is a specialist in the production of high-precision,

rotationally symmetrical workpieces. Originally founded as a screw factory in 1937, the company now manufactures complex CNC components and offers its customers a range of special finishing processes including honing, between-centers and centerless grinding and options for super-finishing. The 165 employees at the Swiss company primarily produce turned parts measuring up to 120 mm (4.724”) in diameter. But the Aeschlimann team are also experts in machining, produc-

NIKHIL NAYAK  
Managing Director  
NN Combined  
Engineering Agencies  
Pvt Ltd



Source: Horn/ANNEA

Ticking over like a Swiss watch: Traditional cam-controlled sliding-head lathes are an essential part of large-scale series manufacturing.

ing milled parts with lengths of up to 300 mm (11.811”). Its customers include companies in the Watchmaking, Automotive, Hydraulics, Machinery and Electronics industries. Aeschlimann also supplies its high-precision Swiss products to the Medical, Measuring Technology and Bicycle sectors.

### 150,000 Parts per Year

Diethelm manufactures a connector in Arcap AP 1 D – a free-machining Cu-Ni-Zn alloy with lead as an additive (CuNi25Zn12Pb1) – for a turned part for the Electronics sector. The component has a length of 5.8 mm (0.228”) and a diameter of 0.7 mm (0.028”) to 1.8 mm (0.071”). Aeschlimann produces around 150,000 of these workpieces a year. “Before switching to HORN tools, we produced the parts on our old cam-type sliding head lathes,” says Diethelm. The machines – which have been in use since the 1980s – are still commonplace in Switzerland. “These

machines are essential in the large-scale series production of very small turned parts that require a high degree of precision and fast cycle times. If they’re correctly configured, they can run for days on end without intervention. We produce the cams for the machines ourselves,” explains process expert Stampfli. How-



Source: Horn/ANNEA

The tool edge is ground to a sharp and precise finish.

ever, the company encountered an issue when producing this component: the material used is comparatively soft. Copying the 0.2 mm (0.008”) deep workpiece profile resulted in small burrs forming on the edges and caused small ‘slugs’ to be produced when parting off. “Minor damage to the surfaces was another problem. This damage was caused by the guide bush during the sliding-head turning process,” says Diethelm. An absence of burrs, a high surface quality, and a good finish after parting off are key criteria for the turned part. To solve the problem, Stampfli and Diethelm switched the machining process over to a Tornos SwissNano CNC sliding-head lathe – which was specifically designed to machine micro-components with a high degree of precision. The workpiece profile would now be produced with a plunge cut instead of being copied. “There was another tool manufacturer in the running for

To solve the problem of burrs, slugs, and surface damage, especially due to the soft material used, the machining process was switched from cam-type sliding head lathes to a Tornos SwissNano CNC sliding-head lathe – which was specifically designed to machine micro-components with a high degree of precision.

The  $\mu$ -Finish tool system is primarily aimed at micro-machining users. Based on the S274 system, it features inserts that have been ground with outstanding precision. Every tool undergoes a comprehensive round of inspections during the production process to ensure that its cutting edges deliver excellent standards of quality.



Source: Horn/NNCEA

Aeschlimann uses S274 system products for sliding-head turning and grooving.

supplying the tool concept alongside HORN. It was a tight race, but we didn't give the other company the contract due to chipping problems and limited tool life," explains Diethelm. Turning technology specialist Dominik Läng from Dihawag worked with tool engineers from Tübingen to develop a solution using the HORN S274 grooving system.

#### 45,000 Recesses per Insert

"The quality of the tool edge is the crucial factor," says Läng. The microgeometry of the cutting edge is extremely sharp. With the help of the ground chip breaker, it was possible to achieve reliable chip control. Diethelm was also able to use the tool system with higher cutting values. The service life of the double-edged insert was boosted to 45,000 recesses. The shape of the indexable insert is precision ground, and the profile depth is 0.2 mm (0.008"). The defined inner radii of 0.05 mm (0.002") are ground to chamfer

the workpiece edges. "HORN really knows what it's doing when it comes to grinding inner radii. It's important to remember that it is not only the inner radius that needs to be considered. In form grinding, the side and front relief angles of the insert also require expert knowledge. We can even grind inner radii to a defined size



Source: Horn/NNCEA

Checking the cutting edges after 22,500 recesses.

as low as 0.025 mm (0.001") with tolerances of just a few microns," explains Läng. The machining process for the turned part is as follows: First, the workpiece is machined to an initial diameter of 0.7 mm (0.028") in a sliding-head turning process. The surface is then pre-turned for subsequent form plunge cutting to a diameter of 1.46 mm (0.057"). "Due to the ratio between the length and the diameter, the soft material and the cutting pressure, we machine the diameter to leave a 0.06 mm (0.002") allowance," says Diethelm. Different feed rates are programmed for grooving with the wide insert; movement is faster during rapid travel and slows down during the grooving operation to prevent workpiece deflection. At the maximum grooving depth for diameters of 1.4 mm (0.055") and 1.2 mm (0.047"), Diethelm programmed a dwell time of half a second. "Grooving across a small diameter with a



Source: Horn/NNCEA

A successful partnership: Fabian Stampfli talking to Michael Diethelm (both from Aeschlimann), Dominik Läng (Dihawag) and HORN application engineer Dennis Engemann.

wide cutting edge creates high cutting pressure. This can cause the workpiece to be pushed away slightly. We optimized the HORN tool holder so that we can use a special thread to make tiny adjustments to the angle of the tool. This enables us to counteract any tapering of the diameter with a correction angle," he shares. The workpiece is also parted off using a type S274 insert.

#### Fast Tool Solution

After submission of the initial enquiry, it took around six weeks for a finished machining process to be developed and implemented. "We are very satisfied with how our requirements were dealt with. We're impressed with the performance and process reliability of the tools," says Diethelm. In

addition to the tools mentioned in this article, Aeschlimann also uses a number of other HORN tool systems, including type S100 parting-off tools and Supermini inserts for internal profiling. The company also uses HORN  $\mu$ -Finish tools for micro-machining of watch screws.

The  $\mu$ -Finish tool system is primarily aimed at micro-machining users. Based on the S274 system, it features inserts that have been ground with outstanding precision. Every tool undergoes a comprehensive round of inspections during the production process to ensure that its cutting edges deliver excellent standards of quality. Together with the central clamping screw and the precision-ground profile of the indexable insert, the tool holder insert

seat helps the system to achieve indexability to within microns. This, in turn, allows the insert to be indexed in the machine without the need to re-measure the centre height or any other dimensions. In addition to its extensive range of standard profiles, HORN offers custom-made inserts with special designs.

#### HORN in India

Precision Tooling Solutions for the Manufacturing Industries from Paul Horn GmbH are available in India via NN Combined Engineering Agencies Pvt Ltd. (NNCEA). NNCEA provides complete manufacturing solutions including logistics and supply chain management solutions for a wide variety manufacturing industries in the Indian market. 

#### HORN in India

Precision Tooling Solutions from Paul Horn GmbH are available in India via NN Combined Engineering Agencies Pvt Ltd. (NNCEA) in cooperation with select OEM partners. NNCEA provides complete logistics and supply chain management solutions for several major medical manufacturing industries in the Indian market.

"HORN really knows what it's doing when it comes to grinding inner radii. It's important to remember that it is not only the inner radius that needs to be considered. In form grinding, the side and front relief angles of the insert also require expert knowledge."

## TACKLING THE TIME-TO-MARKET CHALLENGE

In a world where speed, precision, and adaptability define success, manufacturers are under constant pressure to enhance performance and sustainability while accelerating time-to-market – a key competitive advantage. With its Hybrid and Laser Metal Jetting (LMJ) technologies, ADDiTEC brings that advantage directly to the shop floor.

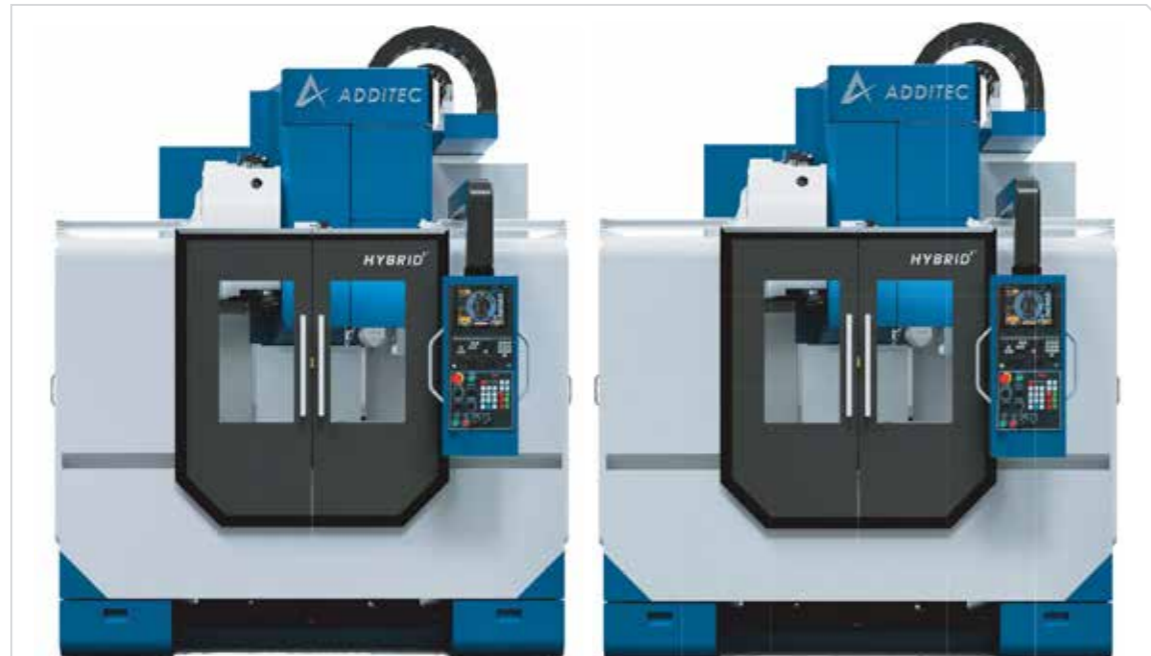

ADDiTEC's Hybrid Platforms (Hybrid 2 & Hybrid 3)

**T**raditional manufacturing methods often require long lead times, expensive tooling, and extensive post-processing. Additive manufacturing, in contrast, can dramatically shorten development cycles by enabling near-net-shape production directly from digital designs. However, not all AM technologies are created equal. Many legacy metal AM systems still involve complex workflows, powder management, or extensive finishing steps, slowing down deployment and limiting accessibility. ADDiTEC's Hybrid and Liquid Metal Jetting (LMJ) platforms represent major leaps toward that goal.

**A Hybrid Approach**  
Our Hybrid 2 and Hybrid 3 plat-

forms integrate three key functions in one compact footprint:

- Laser Wire Directed Energy Deposition (LDED) for high deposition rates,
- LMJ for fine resolution features, and
- CNC Machining for precision finishing.

This combination ensures manufacturers can go from digital model to finished metal part – all in a single machine, without external handling or setup changes. By eliminating transfers between different machines and reducing post-processing steps, the Hybrid workflow dramatically accelerates the delivery of parts. Whether it's building complex prototypes or repairing high-value components, the Hybrid system enables same-day production cycles – something unthinkable with traditional processes.

Our unique ring-shaped laser beam and closed-loop monitoring ensure consistent thermal control and high-quality builds. Combined with coaxial wire feed and adaptive melt pool control, this results in superior dimensional accuracy and high deposition efficiency – key requirements for first-time-right builds.

**Hybrid 2 Platform**  
The Hybrid 2 Platform features LMJ, an innovative additive process offering key advantages to hybrid manufacturing. By utilizing low-cost welding wire, LMJ enables the production of near-net shape parts. This process is notable for its ability to achieve high-resolution metal printing, allowing for the creation of fine, detailed geometries that are often challenging

BRIAN MATTHEWS  
Founder & CEO  
ADDiTEC



## THE **DECISION SUPPORT** YOU NEED FOR **EFFICIENT CONDITION MONITORING** & TO **REDUCE REPAIR COSTS**

Find, report, and fix issues before they become expensive, with FLIR's complete range of Test & Measurement solutions.



Test & Measurement Tools



Thermal & Acoustic Imaging Cameras



Analysis Software

Images for illustrative purposes only.

Secure Storage | Top-tier Service and Support

Learn more about FLIR

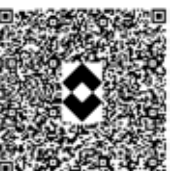

For more information, please call us at +91-11-4560 3555 or write to us at [flirindia@flir.com.hk](mailto:flirindia@flir.com.hk)

Reducing time-to-market is not just about speed — it's about achieving efficiency and sustainability. ADDiTEC's Hybrid and LMJ systems deliver on both fronts. They offer up to 40% lower total cost of ownership compared to traditional powder-bed systems.

for other metal additive processes. The hybrid system further enhances LMJ by incorporating subtractive machining capabilities. These enable post-printing operations to refine surface finishes and achieve tight tolerances. The combination of flexibility and precision makes LMJ particularly suitable for industries requiring high-performance, intricately designed components.

### Hybrid 3 Platform

The Hybrid 3 Platform integrates LMJ, LDED, and CNC machining within a single platform. This multi-tech approach combines the benefits of two additive processes — LMJ and LDED — both of which use low-cost welding wire to produce near-net shape parts. LMJ enables high-resolution capability, while LDED offers high deposition rates, making the system suitable for a wide range of part sizes and applications. Together, these technologies support multi-material manufacturing, enabled by dual additive processing heads. The built-in subtractive process (CNC machining) allows for post-processing to achieve the required surface finish and tight tolerances for parts printed using the two additive processes.

### Key Features of ADDiTEC's Hybrid Platforms

**Multi-Technology Integration:** Both platforms integrate LMJ and CNC machining, while the Hybrid 3 adds LDED for higher deposition rates and multi-material capability.

**Cost Efficiency:** Designed to reduce the cost of goods sold (COGS) through low-cost wire feedstock and compact equipment footprints, the platforms ensure affordability without compromising capability.

**Full Material Utilization:** LMJ technology ensures 100 percent usage of raw material, eliminating waste by forming

parts with precisely ejected molten metal droplets.

**Complex Geometry Capability:** Both systems have successfully produced 90° overhangs and intricate gyroid structures.

**Advanced Processing Heads:** Proprietary LMJ and LDED heads are the result of over a decade of development, offering industry-leading performance.

**Superior Surface Finishing:** Integrated CNC machining allows for high-quality post-processing, ensuring parts meet strict surface finish and dimensional accuracy requirements.

### LMJ: Drop-on-Demand Innovation

When we acquired Elem Additive Solutions from Xerox Corporation, we inherited over a decade of development and more than 300 patents related to LMJ technology. This proprietary process uses molten metal droplets ejected on demand to form parts — a radically different approach from traditional powder-based systems.

### LMJ's key advantages:

- It eliminates the need for powder handling, which improves safety and reduces waste.
- It avoids issues like shrinkage or warpage, enabling the production of parts with tight tolerances.
- Since the process requires no post-processing steps such as sintering or debinding, it simplifies the overall workflow.
- Moreover, with 100 percent material utilization, LMJ enables truly zero-waste production.

### Easy to Deploy, Easy to Scale

One of the most overlooked barriers to adopting AM is complexity. Many systems are costly to maintain, require extensive training, and demand specialized facilities — particularly when powder-based processes are involved.

At ADDiTEC, we've taken a different path by designing systems that are plug-and-play ready, easily operable in standard industrial environments, and safe, with no explosion or toxicity risks. They're also accessible to non-specialist operators after only minimal training, removing the steep learning curve that often hinders adoption.

This means faster ramp-up for new users, lower barriers to entry, and faster go-to-market cycles for innovative applications.

### Economic and Environmental Gains

Reducing time-to-market is not just about speed — it's about achieving efficiency and sustainability. ADDiTEC's Hybrid and LMJ systems deliver on both fronts. They offer up to 40 percent lower total cost of ownership compared to traditional powder-bed systems. Their compact, self-contained design helps reduce facility costs, while the ability to use standard wire or recycled materials significantly lowers input expenses. What's more, with 100 percent material utilization, these systems generate near-zero waste.

### Real-World Applications

From restoring aerospace components to manufacturing custom tooling on the shop floor, our systems are already proving their value in the field.

Key application areas include:

- **Tooling and fixturing** for high-mix environments
- **Spare part production** in Defence and Oil & Gas
- **Rapid prototyping** for new product development
- **On-demand manufacturing** close to point-of-use

Each application underscores how metal AM — when thoughtfully engineered — can redefine supply chains and shorten product launch timelines. 

# 14<sup>th</sup> Die & Mould India International Exhibition



## Experience the Power Behind Every Precision Cut — DMI 2026

Experience unparalleled advantages at India's largest exhibition for tool and die makers. Connect with industry leaders, expand your customer base, and showcase your innovations to a captivated audience.



Organised by  
**TAGMA INDIA**

TOOL AND GAUGE  
MANUFACTURERS  
ASSOCIATION-INDIA

📞 96534 27396 / 97694 07809  
✉ tagma.mumbai@tagmaindia.org  
🌐 www.diemouldindia.org



## TOWARD A FUTURE-READY FACTORY

Renishaw's portfolio is playing a significant role in supporting manufacturers on their journey towards Industry 4.0. A smart manufacturing data platform for industrial process control is the solution industrial factories need. Renishaw Central is a data-driven solution designed to transform the productivity, capability, and efficiency of manufacturing operations.

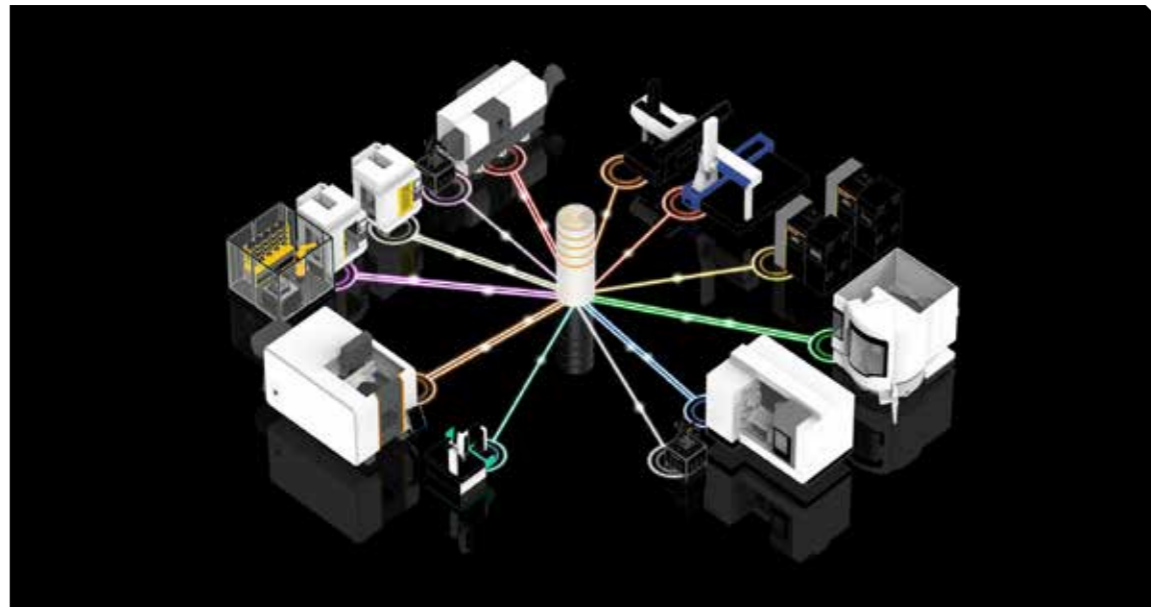

**I**ndustry 4.0 brought the promise to enhance connectivity and data integration, improved productivity and efficiency, automation and process control, optimized asset utilization and enhanced quality and reduced waste. With Industry 4.0 expansion and increasing demand for precision, India is emerging as a key player in global manufacturing, attracting significant investment. Both global and domestic manufacturers are heavily investing in production, support teams, and new product launches. Government initiatives are transforming Manufacturing into a dynamic growth sector. With India's growing position as a manufacturing hub, the machine tools market is set for continued growth, tech-

nological advancements, and increased competition.

### Industry 4.0 Myths

Renishaw Central enables users to exploit digital twin and future factory concepts through:

**Connectivity:** Compare efficiency, accuracy and quality across jobs, machines, and sites

**Consistency:** Limit variability by monitoring live quality output and enable automatic process updates

**Control:** Reduce process setup times on lathes with the use of Intelligent Process Control (IPC)

**Confidence:** Access in-depth analytic features to consolidate real-time data as reports

### A World Full of Data

To analyze one's manufacturing for improving the process,

Renishaw has introduced a structured framework of process control, which is called Productive Process Pyramid™ in its factories. It begins with ensuring the machine tool is well-calibrated and maintained for consistent quality. This Process Foundation level ensures the machine tool's readiness, while Process Setting automates job setups with probing technology, reducing human error and labor dependence. The third level, In-Process Control, shifts measurement from the end of production to real-time monitoring during manufacturing. This allows for immediate adjustments using in-machine probing and shop-floor systems, preventing scrap or rework. Furthermore, Post-Process Verification still involves final in-

### How does Renishaw consider DATA?



spection in a standards room with CMMs, generating reports for end-users like automotive or aerospace manufacturers. Renishaw integrates all these stages with Renishaw Central, a platform that unifies metrology data and enables informed decision-making. This approach ensures every part is 'right first time', boosting efficiency and reducing waste.

With this, the company has helped hundreds of global customers integrate metrology and proactively apply controls using its Productive Process Pyramid™ concept. It's been Renishaw's mission to help its customers to increase productivity, capability and efficiency of their manufacturing.

### Automation, "It's Not Just About Robots"

In the current industrial landscape, automation encompasses a wide range of technologies and processes designed to enhance efficiency, accuracy, and productivity. The company's perspective on automation reflects the industry's shift towards integrating diverse technologies to create more efficient, adaptable, and intelligent systems. It's about leveraging a combination of AI, IIoT, and other technologies to transform

manufacturing processes and improve productivity.

Being at the forefront of automation, Renishaw integrates various technologies to improve manufacturing processes, including:

The simplest form of automation can start with using a probe. Renishaw offers a comprehensive range of probing and tool measurement solutions to enhance CNC machine tool accuracy and efficiency by automating key tasks like tool setup and part alignment.

With Renishaw Central, one can capture processes, machines, and part data, all while collecting information from multiple systems across the shop floor.

For process control, Renishaw offers shop floor gauging solutions that provide real-time data and enable immediate adjustments to manufacturing processes.

Factory automation drives operational efficiency by increasing machine uptime and overall output without the need for additional machines. By combining physical automation (like robotics) with industrial automation (like AI and IIoT) and actionable data, manufacturers can achieve closed-loop process control. This means that processes are continuously monitored and adjusted in real-time.

### The Key to Using Data to Improve Manufacturing

The future is happening today with Renishaw Central. Bringing the power of connectivity to the machine shop floor, the system collects accurate, actionable data on machines, parts, and processes from across the factory, and presents it centrally for insight and interrogation at the point of manufacture.

Renishaw Central collects and provides visibility of machining process data across the factory for insights into the point of manufacture. This can be used to analyze and health-check the performance of devices on the shop floor, examine device utilization and part quality, and to sign off and validate the part.

With Renishaw Central, manufacturers can check the performance of devices on the shop floor, understand device utilization, and examine and validate part quality. User-friendly dashboards show live device data. Data can be passed into industry-leading tools such as Microsoft® Power BI via APIs. Data analytics can then be used for in-process control applications and continuous improvement. This not only increases operational efficiency but also reduces the need for human intervention, building confidence in process automation. 

With Renishaw Central, manufacturers can check the performance of devices on the shop floor, understand device utilization, and examine and validate part quality. User-friendly dashboards show live device data.

CHRIS LUHMAN  
Director - Industrial Metrology Asia Pacific  
Renishaw Metrology Systems Ltd



# IT'S ALL IN THE GRIND

Double disc fine grinding, a precision sharpening process, plays a crucial role in determining the lifespan of double disc grinding wheels. Here's a look at strategies to extend their longevity.



Figure 1: Used grinding and sharpening tools

**A** scientific study by Dr-Ing Marijke van der Meer (Krebs & Riedel Schleifscheibenfabrik GmbH & Co KG) shows that by adjusting sharpening parameters such as pressure, speed, and grain size, the lifespan of double disc grinding wheels and sharpening tools can be significantly extended. This makes a standard sharpening process less advantageous and advocates for a targeted adjustment to the specific requirements of the tool. Technological consulting and optimization at the customer's site can positively influence the cost-effectiveness and efficiency in double disc grinding with planetary kinematics.

## Conditions and Parameters During Sharpening

A test machine from Mjtech,

model AC500F, was used. This has been specifically adapted for Krebs & Riedel to accommodate smaller tool diameters to keep testing costs low. To ensure reproducible sharpening conditions, the wear of the sharpening ring is recorded, documented, and at least one repetition is performed. The coolant used is the emulsion Syntilo 81 E (5.4%). Sharpening rings are immersed or wetted in it, while no coolant is supplied during the sharpening process. Subsequently, the grinding wheels are cleaned. In the standard sharpening procedure, one side is sharpened concavely and once convexly to keep the wheels straight. Only the rotation direction of the inner pin ring changes. The speeds in revolutions per minute (rpm)

are: concave:  $n_{top} 30 / n_{bottom} -36 / n_{middle} -24$  and convex:  $n_{top} 30 / n_{bottom} -36 / n_{middle} 24$ . The main load force is 38 daN, and the sharpening time per rotation direction is 25 seconds, with the first 5 seconds dedicated to wetting with coolant. Wear from both the sharpening ring and lower grinding wheel is recorded – the latter after both sharpening and grinding.

Initially, grinding wheels with specifications 4D 76 X 18 V8318-40 and closed layout are examined, which are sharpened with 57C 220 I 5 V59 (Figure 1). For dulling, components made from aluminum oxide ceramic (Figure 2) are processed. Here, nine components measuring 20 x 20 mm<sup>2</sup> from ALOTEC92 per carrier with five carriers correspond to a material layout of 22.4 percent. The



Figure 2: Aluminum oxide ceramic workpieces

main load speeds are  $n_{top} 200$ ;  $n_{bottom} -200$ ;  $n_{middle} 20$  rpm with a starting grinding force in main load of 30 daN. The removal rate is set at 100  $\mu\text{m}/\text{min}$  with an in-feed per run of 200  $\mu\text{m}$ .

The grinding force increases automatically when dulling the grinding wheels to maintain removal rate. Runs continue until a maximum force of 250 daN is reached to ensure uniform dulling of the grinding surface. In each trial, process cycle times, forces, actual removal rates, and

wear on grinding wheels are documented. For aluminum oxide plates, roughness primarily arises from coarse material structure and is independent of sharpness level; thus, evaluation of component roughnesses is omitted here. Even with a dull tool, a  $Ra > 0.5 \mu\text{m}$  and  $Rz > 5 \mu\text{m}$  are achieved.

To capture sharpness levels under various process variations, a method using graphite imprints has been introduced. Holding devices for graphite pieces

were created using 3D printing. These graphite pieces represent the produced envelope curve of grinding wheel topography as roughness when processed by upper and lower discs.

## Results

Initially starting from the described standard sharpening process, pressure was varied. Higher pressure does not automatically mean sharper discs based on roughness measurements; this is confirmed by material removal on graphite (Figure 3).

The values in Figure 4 were recorded during roughness measurement of graphite; it should be noted that graphite prints correspond to a negative impression of overlaid grinding wheel topography. This means Rvk represents grain tips while Rpk represents topographic valleys (pores/chip space). Rpk and Rvk illustrate that more dulling occurs externally than internally; thus, the center of the cutting tool ring becomes most flattened. The top side remains slightly sharper than the bottom side.

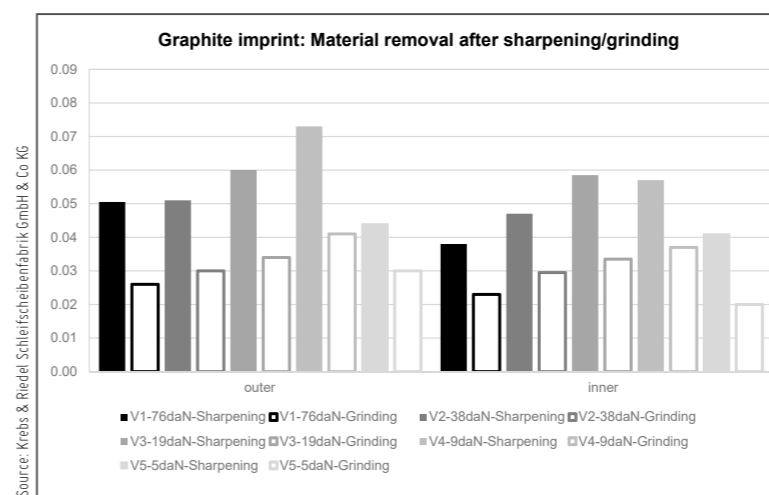

Figure 3: Material removal on graphite after sharpening and after grinding at various sharpening forces

Reducing pressure alongside speeds leads to improved efficiency within both sharpening and grinding processes – the investigation revealed that pressure increased tool wear by more than a factor of three.



For optimal efficiency in double-disc fine grinding, it's advisable not just to maintain standard processes but also implement targeted adjustments on process parameters like pressure or speed to extend tool life while improving overall process efficiency.

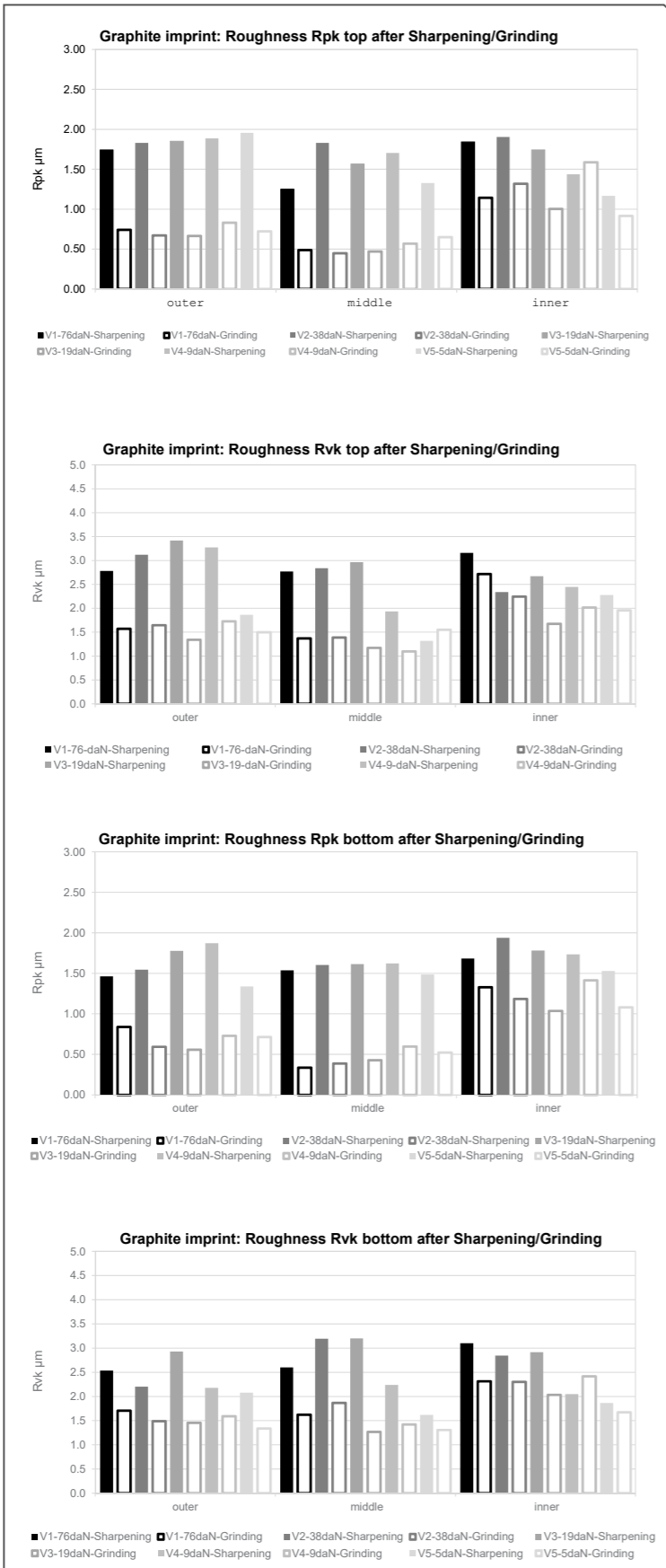

Figure 4: Rpk and Rvk after sharpening and grinding above and below

After sharpening, surfaces are always distinctly rougher than after grinding; Rvk shows less difference between sharpening and grinding compared to Rpk where grains (Rvk) wear less than the bond (Rpk).

Regarding total material removal height, there are minimal differences in grinding processes following pressure variation during sharpening; however, regarding tool wear there's an observable difference greater than a factor of three (Figure 5).

Typically, wear volume of discs  $V_s$  in  $\text{mm}^3$  is compared against total volume  $V_w$  in  $\text{mm}^3$  ground from workpieces to evaluate process efficiency via what's known as G-value. High G-values indicate long tool life:

$$G = \frac{V_w}{V_s} \quad (\text{Formula 1})$$

Here disc wear occurs more during sharpening processes while considering that sharp rings must also be accounted for as 'consumables'. Thus, an efficiency value E is introduced derived from comparing total removal volume  $V_w$  against sum volumes of disc wear  $V_s$  plus sharp ring wear  $V_{SR}$ :

$$E = \frac{V_w}{V_s + V_{SR}} \quad (\text{Formula 2})$$

Besides pressure adjustments were also made to speeds as well as grain sizes during sharpening processes - reducing both pressure and speed positively impacts efficiency while only significant changes in grain size yield effects.

This adjustment directly influences possible charge numbers concerning a set of grinding wheels (assuming a coating thickness of six mm) as well as required number of sharp rings throughout disc lifespan.

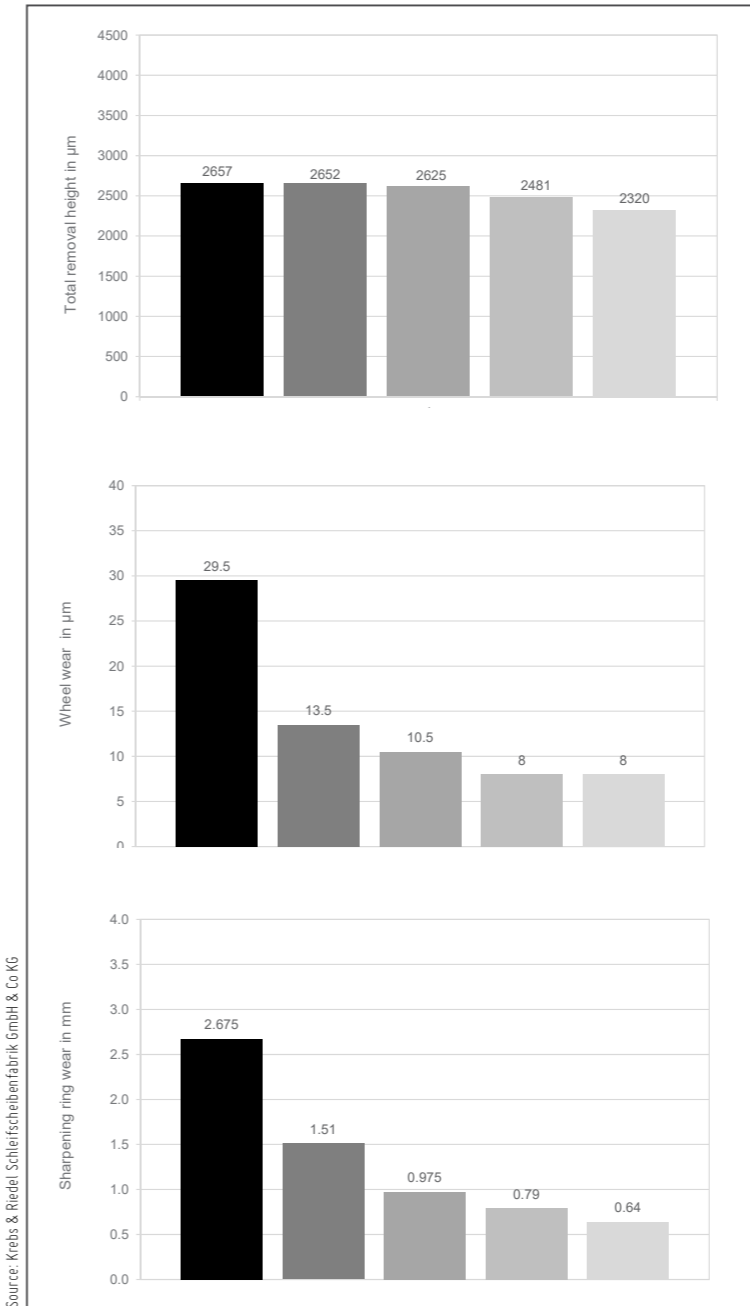

Figure 5: Total material removal height, disc wear and sharpening ring wear

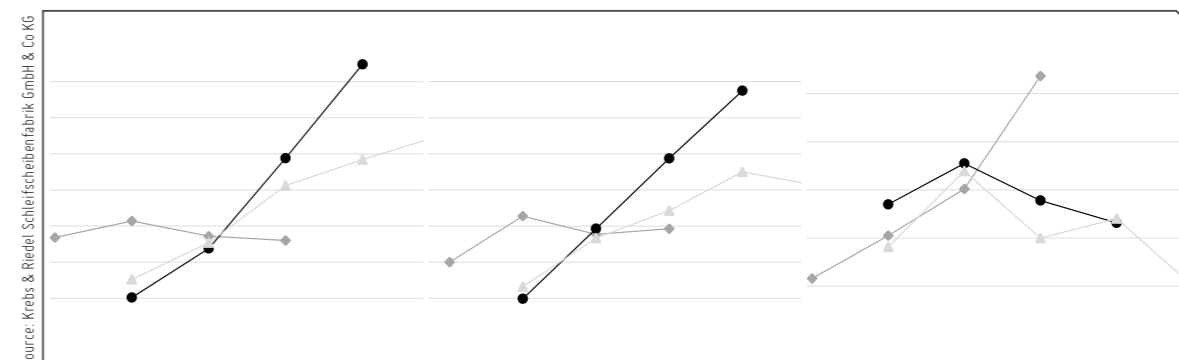

Figure 6: Efficiency across various parameter variations along with possible charge numbers and required sets of sharpening rings

Reducing pressure alongside speeds leads to improved efficiency within both sharpening and grinding processes - the investigation revealed that pressure increased tool wear by more than a factor of three.

Results indicated that lowering pressures along with speeds enhances process efficiency while changes in grain size only had significant effects under strong deviations - these adjustments directly influenced lifespan for sets of grinding wheels along with number needed for sharp rings.

In summary for optimal efficiency in double-disc fine grinding it's advisable not just to maintain standard processes but also implement targeted adjustments on process parameters like pressure or speed to extend tool life while improving overall process efficiency.

Krebs & Riedel specializes in processing brittle hard materials such as glass and sapphire ceramics (SiC and SiN), mixed ceramics and hard metals along with steel and metal alloys processing too. Krebs & Riedel has also developed new fine grain specifications for large surface area grinding within nanometer range featuring high removal rates - the company offers tailored sharpening rings alongside global technological support aimed at optimizing customer tool efficiency and longevity.

Krebs & Riedel specializes in processing brittle hard materials such as glass and sapphire ceramics (SiC and SiN), mixed ceramics and hard metals along with steel and metal alloys processing too.

# A COMMITTED SPECIALIST

With industrial digitalization accelerating at breakneck speed, Utthunga stands apart with its depth, specialization, and vision. Delivering end-to-end services—from IT-OT integration to cybersecurity and automation for industrial OEMs and manufacturers—the company’s capabilities are certainly as broad as they are deep.

**U**tthunga’s journey began in 2007 with a singular mission: to address the growing need for smarter, more connected systems in the industrial world. “At that time, most off-the-shelf digital solutions lacked the domain-centric understanding and capabilities required to meet the complex challenges of industrial environments,” recalls Krishnan KM, Founder and CEO, Utthunga.

The company commenced by solving connectivity and protocol-related challenges, laying the foundation for what would become a deep focus on industrial integration, optimization,

and scalability through purposeful technology. Innovation and R&D became the cornerstones of Utthunga’s journey. “We actively participated in key industrial standards bodies, contributing to technology specifications, reference designs and enabling our customers to build future-ready products. This deep involvement helped us remain at the forefront of industrial digital transformation,” he shares.

## Scaling Industries to New Heights

Looking back at the company’s early focus, the CEO shares how it laid the foundation for

deeper integration and scalable technology offerings and propelled Utthunga’s growth journey. “Over the years, our reputation for delivering reliable, innovative solutions with faster time-to-market has earned us the trust of leading OEMs globally,” he notes.

The company has expanded its customer base across geographies by establishing centers in USA, Europe, Japan and UK. A decade later since its inception, it launched its design-led manufacturing practice. “This strategic move allowed us to offer end-to-end services—from concept to product manufacturing—while building a robust ecosystem of



Source: Utthunga

“Our offerings have evolved to include product engineering, digital IT solutions, process and plant engineering, industrial automation, and domain-specific consulting. This positions us as a full-fledged industrial engineering and solutions company.”

**Krishnan KM**  
Founder and CEO  
Utthunga

partners to support our clients even better,” he adds.

Recognizing the value of real-world feedback, the company implemented customer’s products as turnkey solutions, resulting in the launch of its Industrial Solution business unit. This unit offers automation and digitalization services across sectors such as Oil & Gas, Chemicals, Metals & Mining, Pharma, Power, Utilities, and Discrete Manufacturing. “This was a major step towards realizing our vision of enabling a smart, secure, and sustainable industrial future,” notes Krishnan.

In 2023, the company inaugurated its state-of-the-art Global Engineering Center in Bangalore—a 100,000 sq ft facility dedicated to industrial innovation. It features an industrial experience center with multi-vendor systems, a control lab, hardware assembly lines, and testing labs to visualize, simulate, and experience its offerings.

Powering this continued ascent, Utthunga, today, has eight global offices and a growing team of more than 1,200 ‘Utthungites’ across multiple engineering disciplines. “We proudly serve global OEMs, MSPs, ISVs, and manufacturing companies with capabilities that span the entire value chain—product design,

manufacturing, deployment, and lifecycle support,” he shares.

“Our offerings have evolved to include product engineering, digital IT solutions, process and plant engineering, industrial automation, and domain-specific consulting. This positions us as a full-fledged industrial engineering and solutions company,” he adds.

## A Brand Identity Rooted in Purpose

The name Utthunga—meaning ‘the pinnacle’—is a fitting reflection of the company’s journey. “It reminds us daily of our higher purpose which is our commitment to empower customers and industries to scale greater heights,” aptly describes Krishnan.

The company recently returned to blue as its brand color. “Blue is more than just a color—it’s a reflection of who we are and where we’re headed,” he explains. While the company previously adopted orange to express the company’s energy and vibrancy, the return to blue represents trust, security, and reliability—the values that define Utthunga.

“Our logo captures the spirit of transformation. Just as a mountain rises from the depths of the ocean and reaches toward the sky, our solutions guide data from sensors on the shop floor - all the way to the cloud, bridging the physical and digi-

tal worlds,” says Krishnan, highlighting the company’s renewed focus on being a reliable, trustworthy guide for clients navigating the intimidating trails of industrial transformations.

## A Specialist Among Generalists

In today’s competitive market, Utthunga sets itself apart by being the only engineering services and solutions company exclusively focused on the global industrial ecosystem.

What distinguishes the company from its competitors in the market is its ability to integrate expertise in three critical pillars—Operational Technology (OT), deep domain knowledge, and cutting-edge digital technologies. “This is where Utthunga excels,” remarks Krishnan.

Over the years, the company has made significant investments in building complementary technologies that enhance its OEM customers’ offerings. These include a robust IT-OT integration stack based on OPC UA, industrial edge computing platforms, multi-vendor system integration capabilities, ready-to-deploy asset models, and simulation modules. “These assets empower industries to accelerate their digital transformation journeys efficiently and effectively,” he notes.

Utthunga is driving industrial digital transformation through deep domain expertise, integrated IT-OT solutions, and end-to-end engineering services. With a focus on innovation, cybersecurity, and sustainability, the company empowers OEMs and manufacturers globally.

NITYASREE  
KUMARASWAMY  
Correspondent  
Magic Wand Media  
nityasree@  
magicwandmedia.in



Source: Utthunga

The company's state-of-the-art Global Engineering Center in Bangalore is a 100,000 sq ft facility dedicated to industrial innovation. It features an industrial experience center with multi-vendor systems, a control lab, hardware assembly lines, and testing labs to visualize, simulate, and experience its offerings.



Source: Utthunga

“But our differentiation goes beyond just technology—it’s how we apply technology that truly makes the difference. We combine our strong domain expertise with advanced engineering and digital capabilities to deliver real-world results,” the Founder clarifies.

The company’s value proposition is built upon four foundation pillars: Agility, Innovation, Collaboration, and Sustainability. In terms of agility, “We help customers bring products and solutions to market faster—without compromising on quality. With deep OT and field systems expertise, we are able to adapt quickly, modernize legacy systems, and scale solutions to meet dynamic business demands,” he explains. Innovation is cultivated through Utthunga’s Industrial Center of Excellence, dedicated Innovation Labs, and co-creation platform, uSpark that fuel the development of groundbreaking solutions that directly address industrial challenges. Moreover, the company operates within a strong ecosystem of partners and adhere to structured internal frameworks that foster seamless collaboration.

Lastly, sustainability is rooted in every stage of the company’s operations, from the design to deployment of energy-efficient solutions that support sustainable operations across the industrial value chain.

### Integrated Solutions Across the Industrial Value Chain

“Today, industrial OEMs and manufacturers need smart orchestration partners that provide integrated, impact-driven solutions across the entire value chain—from product engineering to project integration and lifecycle management. That’s exactly where we add value,” he emphasizes.

The company is one of the very few that offers expertise in various solutions such as Process Technology (PT), Operational Technology (OT), Enterprise Technology (ET) & Information Technology (IT) capabilities under one roof.

This integrated solution package offers tremendous value. For OEMs, it provides a one-stop partner for product engineering who not only understands the product lifecycle but also brings a system-level understanding of

their products and domain applications, backed by years of focused industrial expertise. Meanwhile for end industries, the company acts as a turnkey digital integrator—connecting the best-fit software and hardware solutions from different OEMs to drive automation and digitalization.

### The Convergence of IT-OT

Offering his knowledgeable insights on the industry, Krishnan says, “With the advent of newer technologies and the rising need for digital transformation, IT-OT integration has emerged as a critical challenge for manufacturers, particularly in brownfield plants.”

Today, it’s not just about linking assets within a facility but also about enabling the digital journey for enterprises, including integration with multi-vendor systems and cross-functional enterprise operations. “This complex environment demands expert guidance to craft the right PT-OT-ET-IT integration strategy—and that’s where we come in,” he explains.

Leveraging its cross-functional expertise in industrial connectivity and protocols, Utthunga



Source: Utthunga

adds significant value by identifying and prioritizing connectivity first and interoperability next—the key enablers of modern industrial digitalization.

Today, manufacturers are also increasingly embracing vendor-neutral integration options, with standards like OPC UA playing a pivotal role. Additionally, this convergence also enables improved monitoring and control of industrial processes, optimizing resource usage and reducing waste. These efficiencies translate into enhanced energy performance and a lower environmental footprint.

“Ultimately, as the advantages of smarter, interconnected systems become increasingly evident, IT-OT integration emerges as a critical enabler of resilient, forward-thinking manufacturing,” the Founder adds.

### Cybersecurity: Building Trust into Every Layer

Utthunga’s cybersecurity offerings cover every layer with an approach that focuses on designing and architecting end-to-end secure systems across the enterprise value-chain. They include:

**Security Assessments and Audits** that includes gap analysis against standards like IEC 62443, NIST, ISO 27001, OT & IT risk assessment and maturity mapping, and compliance readiness checks as per key laws and standards, such as the European Cyber Resilience Act.

**Product and System Security Engineering** includes the integration of DevSecOps practices across the development lifecycle; threat modeling, secure coding practices, and vulnerability management; as well as security hardening of devices, applications, and embedded systems.

**Centralized Cybersecurity Frameworks** include the design and deployment of end-to-end security architecture; continuous threat detection and response; and network segmentation and micro-segmentation for ICS and SCADA.

**Secure IT-OT Convergence** include asset visibility and segmentation strategies; secure remote access and privileged access management (PAM); and real-time monitoring of OT endpoints and IIoT devices.

**Verification, Validation & Testing Services** include function-

al, protocol, and performance testing; Site Reliability Engineering (SRE) testing for production-readiness; automated test frameworks to minimize manual effort; and compliance testing for industrial communication standards and safety norms.

### Looking Ahead: Industry 5.0 and Beyond

“As we advance towards Industry 5.0, we’re witnessing a significant increase in technology readiness in the Manufacturing industry,” he keenly points out. “Government initiatives like ‘Make in India’ are also accelerating this transition, resulting in rising demand for robust, intelligent, innovative solutions for smart manufacturing.”

Agentic AI is a key focus area for the company, and it is dedicating significant R&D efforts towards enabling the shift to ‘dark factories’ with fully autonomous operations. It also looks forward to building proprietary AI-based knowledge management systems to address the skill gaps in industrial digitalization. Above it all, sustainability remains a central anchor for the future. 

Agentic AI is a key focus area for the company, and it is dedicating significant R&D efforts towards enabling the shift to ‘dark factories’ with fully autonomous operations.

## ONE VISION, FIFTY YEARS STRONG

EMO Hannover 2025 marks its golden anniversary this year, celebrating five decades as the world's leading trade fair for production technology. In the lead-up to this edition, the EMO Hannover 2025 World Tour in India, organized by the German Machine Tool Builders' Association (VDW), was successfully held across five major cities, from April 21-25, 2025.



Source: Magic Wand Media

**E**MO Hannover 2025 World Tour in India began in Pune on April 21, 2025, followed by consecutive events in Chennai on April 22, 2025, Bangalore on April 23, 2025, Ahmedabad on April 24, 2025, and wrapped up in NCR (Delhi Region) on April 25, 2025. The roadshow was led by Rajesh Nath, Managing Director, VDMA India Services Pvt Ltd, German Engineering Federation (VDMA); Dr Markus Heering, Executive Director, VDW; Christian Pfeiffer, Senior Vice President - Sales and Member of

the Management Board, Deutsche Messe AG, to promote the 50<sup>th</sup> edition of the EMO Hannover show scheduled to take place from September 22-26, 2025, in Hannover, Germany.

### Connecting Through Conversations

Emphasizing the importance of global platforms like EMO Hannover, Nath noted, "India needs access to advanced technology, and exhibitions such as EMO Hannover offer Indian manufacturers the opportunity to source it, whether through global players,

joint ventures or collaborations." He highlighted India's progress in the Manufacturing sector and remarked, "When India becomes a US\$ 5 trillion economy, the aim is that the Manufacturing sector will contribute US\$ 1 trillion to the economy." Dr Heering elaborated on the trade fair's global significance saying, "Fifty years of EMO is a long history. EMO Hannover is by far the most international show in the world." Highlighting its unique value for both exhibitors and visitors, he added, "With participants from 140



Source: Magic Wand Media

countries, the show offers unmatched global reach. There's no other platform where you can meet so many people from so many countries in such a short time."

He further delved into the core themes of the exhibition this year—automation, digitalization, and sustainability—referring to them as the 'magic triangle' shaping advanced manufacturing.

Pfeiffer spoke about the charm of the city of Hannover as well as the strategic location of the trade fair venue that add to the overall EMO experience. He also offered advice to Indian MSMEs and SMEs looking to partake in the exhibition, emphasizing that the size of a company's booth does not de-

termine its success at the show. He also touched upon the concept of 'serendipity'—a fundamental benefit of physical tradeshows. "When people meet by coincidence, when they see a new product by coincidence, something happens," he noted. "It's hard not to make use of serendipity during a trade show with close to 2,000 exhibitors and more than 100,000 visitors."

### Pune: The Road to Hannover Begins Here

During the Pune event, Mohini Kelkar, Director Business Development, Grind Master Machines Pvt Ltd, a veteran exhibitor at EMO Hannover, shared her views on the show, "We visited EMO in 1997 and saw

microfinishing technology for the first time. It caught our attention, and we decided to develop it in India," she recalled. "EMO gave us insight into what we needed to create for the international market—and today, this has become our most manufactured machine." Nishikant Ahire, Chairman & Managing Director, Ahire Machine Tools Pvt Ltd, emphasized the value of global exposure as the company prepares to exhibit for the first time at EMO. "If you're thinking of going global, you need to be on a global platform. EMO Hannover is where you get that kind of exposure," he said.

### Next Stop: Chennai

Often referred to as the 'Detroit

Celebrating 50 years, EMO Hannover 2025 is the world's largest trade fair for production technology. The 'magic triangle' of automation, digitalization, and sustainability shapes this year's event.



Source: Magic Wand Media

NITYASREE KUMARASWAMY  
Correspondent  
Magic Wand Media  
nityasree@  
magicwandmedia.in



EMO Hannover 2025 World Tour in India began in Pune, followed by consecutive events in Chennai, Bangalore, Ahmedabad and NCR (Delhi Region).



“EMO is the abbreviation for a French word, “Exposition Mondiale de la Machine Outils” which means global machine show. EMO Hannover has always had a global approach with innovation from a global perspective.”

**Dr Markus Heering**  
Executive Director  
German Machine Tool  
Builders' Association  
(VDW)



“Indian exhibitors and visitors will be able to witness advanced technology at EMO Hannover 2025 and connect with global players. The exhibition offers Indian manufacturers the opportunity to source it, whether through global players, joint ventures or collaborations.”

**Rajesh Nath**  
Managing Director  
VDMA India



“As an exhibitor, it's important to understand that your booth and overall participation go beyond simply displaying a poster or a product—it's about taking customers on a journey. Showcase the core of your expertise, and you will be successful.”

**Christian Pfeiffer**  
Senior Vice President - Sales  
Member of  
Management Board  
Deutsche Messe AG

of India', the Chennai edition of the tour witnessed the presence of K Soundhar Rajhan, Chief Strategy Officer, LMW Ltd; C Renganathan, Managing Director, Chennai Metco Pvt Ltd and S Suresh Kumar, Managing Director, Veltech Auto Part (India) Pvt Ltd. Speaking about the company's

debut at the exhibition, Soundhar Rajhan said, “We have participated in all the major Indian and Asian exhibitions and now are ready to showcase our products on this prestigious global platform.” He attributed the company's move to the strong opportunities available in the European market.

Emphasizing the value of long-term participation in the show, Renganathan noted, “We've been attending EMO for 20 years now. Our goal is to increase exports, and for that, we need visibility, and EMO offers a platform for enhancing our visibility.” From a visitor standpoint, Kumar shared how his previous experi-



Source: Magic Wand Media



“We have been participating in EMO since 2005, and it has consistently served as a valuable platform to showcase our technology. EMO offers Indian companies outstanding global exposure.”

**Mohini Kelkar**  
Director Business  
Development  
Grind Master Machines  
Pvt Ltd



“I have had the opportunity to visit EMO several times and explore the wide spectrum of technologies the show features. This year, since we are exhibiting, EMO Hannover holds even greater significance for us.”

**K Soundhar Rajhan**  
Chief Strategy Officer  
LMW Ltd



“Since 2011, we've been exhibiting independently. I'm proud to share that today, Sphoorti exports 50 percent of its turnover to over 25 countries—an achievement largely shaped by our experience at EMO.”

**R K Purohit**  
Managing Director  
Sphoorti Machine Tools  
Pvt Ltd

ences at the exhibition, coupled with the opportunity to witness cutting-edge technology, influenced his business decisions.

**Insights from the Bangalore Event**

The event in the Silicon Valley of India, Bangalore, featured prominent industry players,

such as R K Purohit, Managing Director, Sphoorti Machine Tools Pvt Ltd and Anirudh Ravi, Head - Supply Chain Management, Fenwick and Ravi. Purohit highlighted his company's long-standing association with the show, remarking, “EMO is one of the biggest machine tools shows in the

world. It provides a platform to showcase new products to a global audience and offers a great opportunity to tap into export markets.” In alignment Anirudh shared how the company's consistent presence since 2003 has transformed their business. “We have significantly improved our prod-



Source: Magic Wand Media

The final stops in Ahmedabad and Delhi NCR rounded off a successful roadshow. The focus of all the five editions remained on encouraging companies across India's industrial corridors to be a part of the world's biggest metalworking show.

As the world's leading trade fair for production technology, EMO Hannover offers a unique platform under the motto 'Innovate Manufacturing' to establish international contacts, tap into new business opportunities, and gain a comprehensive overview of the industry's global offering.



“When it comes to showcasing our products internationally, EMO Hannover is by far our first choice. This trade show has given us the confidence to showcase our products to the global market.”

**C Renganathan**  
Managing Director  
Chennai Metco Pvt Ltd



“From years of experience I can say that if you're thinking of going global, you need to be on a global platform. EMO Hannover is where you get that kind of exposure.”

**Nishikant Ahire**  
Chairman & Managing Director  
Ahire Machine Tools Pvt Ltd



“The main purpose to visit EMO comes down to one powerful question. ‘Do you work in the business, or do you work on the business?’ If you're serious about working on the business, EMO Hannover is the ideal platform.”

**Anirudh Ravi**  
Head - Supply Chain Management  
Fenwick and Ravi

uct quality, thanks to the exposure to international brands, customers, and visitors,” he noted, adding that about 30 percent of their business now comes from exports—primarily from Europe. “This is a tremendous opportunity for Indian companies, re-

gardless of size,” he emphasized. “Even if you can't participate as an exhibitor, attend as a visitor. Spend four to five days exploring the show—it's invaluable.”

**Five Cities, One Clear Message**  
The final stops in Ahmedabad

and Delhi NCR rounded off a successful roadshow. The focus of all the five editions remained on encouraging companies across India's industrial corridors to be a part of the World's biggest Metalworking Show. 



Source: Magic Wand Media

# IMTEX FORMING 2026

International Forming Technology Exhibition

Concurrent Shows



21 – 25 January 2026  
BIEC, Bengaluru

## Forming the Future of Manufacturing

Asia's Largest Exhibition on Metal Forming and Manufacturing Technologies

**BOOK YOUR SPACE TODAY**

Organiser



Indian Machine Tool Manufacturers' Association

Venue



# BREAKING DOWN SILOS

Putting innovation at its core, Dassault Systèmes' flagship event – 3DEXPERIENCE Modeling & Simulation (MODSIM) India 2025 – unfolded on May 6 at JW Marriott Hotel, Pune. The conference addressed the growing complexity of industries by spotlighting how modeling, simulation, and generative technology can help design smarter, optimize faster, and innovate sustainably.



Source: Magic Wand Media

**T**hemed 'Generative Experiences with MODSIM: Reshaping the Future of Innovation', the conference doubled up as an immersive journey into the future of industrial transformation—driven by design and simulation. Modeling & Simulation (MODSIM) equips teams to tackle real-world challenges, right from the start of the design process, thus reducing development costs and delivering high-performance solutions.

**Signs of Industry Evolution**  
The event highlighted core areas of design, modeling, and simulation, including digital transformation and simulation democ-

ratization. It featured keynote speakers from large OEMs showcasing the real-world benefits of MODSIM and how it supports future-ready design strategies, and customers' user stories currently transitioning to the MODSIM approach, sharing their challenges, learnings, and impact. Industry workflows' live demonstrations put MODSIM into action, highlighting its application in conceptual/generative design and simulation-driven engineering. Also, the conference spotlighted new functionalities of Dassault Systèmes' industry leading brands CATIA, SIMULIA, NETVIBES, and ENOVIA, with the mission

to help prepare these communities and users for tomorrow's economy. The conference opened with a keynote 'Generative Experiences with MODSIM: Reshaping the Future of Innovation' delivered by Rajiv Aramadaka, Director, CATIA Sales & Global Affairs, Public Services, Dassault Systèmes India, and Ankur Sharma, Director, SIMULIA Sales, Dassault Systèmes India. Dhiraj Nahar, Industry Process Expert & Director, Dassault Systèmes, joined Shigetou Yasuhara, BEV Development Division - I, General Manager, Honda, in the session named 'MODSIM Powered Digital Transformation at Honda.'

MURALI SUNDARAM  
Correspondent  
Magic Wand Media Inc  
murali.sundaram@  
magicwandmedia.in



"MODSIM isn't just a buzzword anymore—it's the backbone of efficient product development. Synchronized modeling and simulation are becoming the norm for those chasing speed and precision."

**Praveen Mysore**  
Industry Consultant  
Senior Director  
Dassault Systèmes India

Ashok Joshi, Head - Product Design, Kinetic Engineering & Kinetic Walls & Volts, spoke on 'Unified Design & Simulation for New Product Development'. 'Power of Integrated Design & Simulation through MODSIM Approach' was discussed by Anjaneyulu Chilakapati, India Industry Process Consultant Specialist, CATIA, Dassault Systèmes India; Dayanidhi Panda, SIMULIA Industry Process Consultant, Senior Manager,

Dassault Systèmes India; and Logesh M, India Industry Process Consultant, Dassault Systèmes India.

Strategies for maintaining a single, scalable model across thousands of variants were discussed by Sridhar Lingan, Associate Chief Engineer, Mahindra & Mahindra, and Abdelhakim Aissaoui, Global SIMULIA Industry Process Consultant, in 'MODSIM Advanced Common Model for Simulations'.

Other tracks included 'Leveraging MBSE to Empower Multi-disciplinary MODSIM for Software Defined Vehicles' by Thomas Brun, Industry Process Consultant, Senior Manager, Dassault Systèmes; 'MODSIM Approach for Electrical System Design and Simulation for EMI/EMC applications' by Dushy-anth Gala, SIMULIA Industry Process Consultant Associate, Dassault Systèmes India and Ragul Anand P, INDIA Infrastructure & AEC Industry Industry Process Consultant, Dassault Systèmes India; 'MODSIM powered AI using SIMULIA solutions' by Geetha Avula, Industry Process Consultant Director - SIMULIA India, Dassault Systèmes India; 'Generative Design with CATIA Solutions' by Ganesh Prasad, Industry Process Consultant Director, CATIA, Dassault Systèmes India.

### From Silos to Synchrony

A key session on 'Transforming Modeling & Simulation using



"At the center of Generation 7 is the AI-powered virtual twin, a living, breathing model you can interact with, far beyond the static 'digital twin' of yesterday."

**Klaus Krohne**  
SIMULIA APAC Senior Sales  
Director  
Dassault Systèmes

'Generative Experiences' was headed by Praveen Mysore, Industry Consultant, Senior Director, Dassault Systèmes India and Klaus Krohne, SIMULIA APAC Senior Sales Director, Dassault Systèmes. "In the yesteryears, modeling and simulation used to be siloed," said Mysore, setting the tone for his session. "Bringing a car to market used to take five years. Today, that's down to 18 months. To keep up, we must model and simulate synchro-

A dedicated 3DEXPERIENCE Playground at the venue brought the theme to life. It displayed Dassault Systèmes' solutions and some of the newest features.



Source: Magic Wand Media



**MODSIM 2025 showcased cutting-edge applications of AI-powered virtual twins and simulation-driven decision-making, introducing Dassault Systèmes' Generation 7 solutions.**



Source: Magic Wand Media

nously, validating and maturing the product simultaneously.” This need for real-time, agile design processes has propelled MODSIM from concept to necessity. As Mysore emphasized, “MODSIM isn’t just a buzzword anymore—it’s the backbone of efficient product development.” Drawing from successful case studies around the world and increasing momentum in India, he noted, “Companies are waking up to its value—synchronized modeling and simulation are becoming the norm for those chasing speed and precision.”

**New frontier: Data, IP & AI** Picking up the baton, Krohne steered the audience into the future with Generation 7, a groundbreaking evolution of Dassault Systèmes’ solutions. “At the center of this is the AI-powered virtual twin, a living, breathing model you can

interact with, far beyond the static ‘digital twin’ of yesterday.” What makes this virtual twin truly transformative is its ability to simulate ‘physics-based behavior’ in real time, offering real-world answers, a perfect example of ‘simulation-driven decision-making.’ Krohne also highlighted the challenges. “AI is only as good as the data it’s trained on,” he pointed out. “And beyond that, who owns that data? Who holds the IP? These are questions the industry must grapple with for the next decade.” He positioned the 3DEXPERIENCE platform as the answer, offering end-to-end traceability and data integrity for users navigating these complexities. However, what truly impressed many attendees was the speed of the simulation, which—as per Krohne—‘changes everything.’ “Designers can now perform ‘what-

if’ analysis instantly—no need to wait on experts,” he concluded.

**Playground of Possibility** A dedicated 3DEXPERIENCE Playground at the venue brought the theme to life. It displayed Dassault Systèmes’ solutions and some of the newest features in addition to offering guided tours and presentations on electric drive engineering and more. From enabling faster innovation for engineers to ensuring businesses remain secure, safeguarding their IP assets in an AI-driven landscape, the MODSIM 2025 Conference presented a vision that is not just ready for the future, but set to define it. While Dassault Systèmes works to further deepen the integration of design and simulation, one sentiment was felt across the day: the future of innovation is integrated, intelligent, and instantaneous. 



Source: Magic Wand Media



Indian Machine Tool  
Manufacturers' Association



Manufacturing Technology  
Training

An IMTMA initiative

# Hone your Manufacturing Skills Anywhere, Anytime



## E-learning courses

Get started Now !

Log on to [www.imtmaelearn.in](http://www.imtmaelearn.in)

Contact Mr. Naveen G S (+91 9742626488 ; naveen.gs@imtma.in)



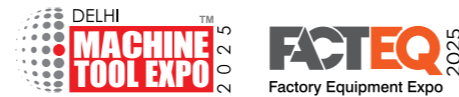

## THE SHOW WHERE GRIT DROVE GEAR

The fifth edition of Delhi Machine Tool Expo (DMTX), co-located with the second edition of Factory Equipment Expo (FACTEQ), from May 9-12 at Bharat Mandapam, Pragati Maidan, New Delhi, was a remarkable display of India's industrial grit. Organized by Indian Machine Tool Manufacturers' Association (IMTMA), the event successfully brought together advanced technologies, business networking opportunities, and industry insights—despite challenges related to global uncertainties and logistics.



Source: Magic Wand Media

**I**n his welcome address at the inauguration of DMTX 2025, Rajendra S Rajamane, President, IMTMA, acknowledged the swift turnaround behind the event, stating, "We're thrilled to have successfully organized the show in just 48 hours,"—a testament to the commendable efforts of IMTMA and its partners in delivering a seamless experience. He went on to emphasize the strategic role of the Machine Tool industry, noting, "The Machine tool industry is the key to manufacturing growth, and supports a significant research in varied sectors." Highlighting India's accelerat-

ed momentum—driven largely by metal cutting, which constitutes 75 percent of the growth driven by industry demands from Electronics, Semiconductors, and Automotive sectors, Rajamane shared, "In terms of global positioning, the Machine Tool industry in India ranks 9<sup>th</sup> in production and 6<sup>th</sup> in consumption, as per 2023 Gardner Intelligence report." Adding to this, Jibak Dasgupta, Director General & CEO, IMTMA, highlighted the industry's growth trajectory, saying, "Our data-backed reports indicate the industry's forward movement in production and

consumption in both metal forming and metal cutting." He also emphasized the importance of global outreach and export strategy, noting, "We've created a special export-focused group. When we attend global trade shows, we analyze and monitor gaps and plan interventions. We aim to grow India's Machine Tool industry's presence not just domestically but also globally." Vijay Mittal, Joint Secretary, Ministry of Heavy Industries (MHI), Government of India (GoI), graced the opening ceremony as the 'Chief Guest', and Premjit Lal, Executive Director, India Trade Promotion Organisation (ITPO),



Source: Magic Wand Media

as the 'Guest of Honor'. Underscoring the significance of such platforms in boosting domestic innovation, Lal said, "This is a great occasion where manufacturers from different industries have gathered together for a four-day event. They will be focusing on technological and innovative progress of Indian products on display." Echoing similar sentiments and highlighting India's transformation, Mittal shared, "The Indian Machine Tool industry's size was roughly INR 7,500 crore in 2014, and we've reached nearly INR 27,000 crore by 2023-24. This is an indication that there has been a growth of around 3.5X over a decade. We must now focus on achieving trade balance through indigenous excellence."

### Spotlight on Exhibitor Excellence

With over 250 exhibitors from 10 countries, DMTX 2025 offered a wealth of next-gen manufacturing technology. AceMicromatic Group showcased a formidable lineup, attracting attendees from the Automotive, Aerospace, and Medical sectors. "Our booth was designed as a complete solutions ecosystem," shared Amit Goel, Assistant General Manager, Marketing & Service Division, Ace Designers Ltd, endorsing the Group's complete portfolio coupled with IIoT solutions. "We got a total of 249 leads and 23 orders worth INR 4.25 crore," he revealed. "Our Turn Mill Center/Polygon Turning and compact DTC-350XL was the point of attraction. Our simulator also gar-

nered significant interest from ministry delegates and educational institutes." LMW's booth attracted an engaged flow of visitors, leading to a noteworthy generation of potential leads. "The expo served as an effective platform for networking with industry professionals and decision-makers, facilitating meaningful business discussions. The diverse visitor base, including representatives from various industry sectors, contributed to the dynamic atmosphere at our booth," shared Manoj Kumar, Regional Head - Delhi, LMW Ltd. The company showcased a range of advanced CNC machines, which garnered considerable attention. "Our S Turn 2M - Compact Turnmill Center, LTV 30 Plus - Vertical Turning Cen-

DMTX 2025, co-located with FACTEQ 2025, featured over 250 exhibitors from 10 countries, presenting cutting-edge manufacturing technology, including standout innovations like LMW's JD2 L - compact machining center, BFW's Prima 55 Pro HMC, and AceMicromatic Group's advanced machining centers.



Source: Magic Wand Media

SOVAN TUDU  
Assistant Editor  
Magic Wand Media  
sovan.tudu@  
magicwandmedia.in



DMTX 2025 was organized and executed within just 48 hours, reflecting IMTMA's operational agility and the collective resilience of the Indian machine tool industry amid logistical and geopolitical challenges.



“The size of Indian machine tool industry was roughly INR 7,500 crore in 2014, and we reached nearly INR 27,000 crore in 2023-24. This is an indication that there has been a growth of around 3.5X over a decade.”

**Vijay Mittal**  
Joint Secretary  
Ministry of Heavy  
Industries (MHI)  
Government of India (GoI)

ter, JD2 L - Compact Machining Center, and J2 R - Vertical Machining Center with RAPC. These models were appreciated by visitors and customers for their precision, speed, and suitability for various industrial applications, he informed. Meiban Engineering Technologies Pvt Ltd, an associate compa-



“We're thrilled to have successfully organized the show in just 48 hours. The machine tool industry is the key to manufacturing growth, and it supports significant research in varied sectors.”

**Rajendra S Rajamane**  
President  
Indian Machine Tool  
Manufacturers' Association  
(IMTMA)

ny of Muratec, Murata Machinery, Ltd, Japan, received visitors from the North Indian Automobile industry, including Tier 1, 2, 3, and 4 visitors, as well as customers from the replacement part market. “With many of our known as well as new customers visiting our booth, this was the platform where all the pros-



“Our data-backed reports indicate the industry's forward movement in production and consumption in both metal forming and metal cutting.”

**Jibak Dasgupta**  
Director General & CEO  
Indian Machine Tool  
Manufacturers' Association  
(IMTMA)

pects could reach us and we could demonstrate our technologies to them,” said Rishi Kapoor, Associate Vice-President & Country Head, Meiban Engineering Technologies. “We received around 8 to 10 new enquiries, many of which show strong potential to convert into business. Our ML400 Shaft Turning Machine



Source: Magic Wand Media



“Our booth was designed as a complete solutions ecosystem. We got a total of 249 leads and 23 orders worth INR 4.25 crore. Our Turn Mill Center/Polygon Turning and compact DTC-350XL was the point of attraction.”

**Amit Goel**  
Assistant General Manager  
Marketing & Service Division  
Ace Designers Ltd

with Twin Turret drew the most attention and was highly appreciated by customers—particularly for its performance.”

#### Market Voices

“Despite the current geopolitical tensions impacting overall turnout, DMTX 2025 was a well-organized event with a strong

quality of visitors,” noted Vijay Zaritaklikar, National Sales Manager, UCAM Pvt Ltd.

“There was a strong interest in our high-precision rotary tables, especially the 4<sup>th</sup> axis models, which drew attention from automation-driven manufacturers,” he shared. “Most of our interactions were with players from the Automotive sector, followed by those from General Engineering and Agricultural Machinery industries.”

Offering a clear market perspective and engaging with serious buyers across industries seeking productivity-driven solutions, Vikas Soni, Regional Manager - Sales at Jyoti CNC Automation Ltd, shared, “We saw a healthy mix of visitors—from decision-makers at large OEMs to MSME business owners—reflecting strong interest across segments. In terms of lead generation, we recorded a significant number of qualified inquiries, especially from the NCR and nearby regions.”

Among the machines that drew the most attention for Jyoti CNC Automation were CNC Turning Centers with Automation, Vertical Machining Centers (VMCs), and advanced 5-Axis and Multitasking Machines, which are particularly popular with Tier-1 and export-oriented manufacturers aiming to reduce setups



“With many of our known as well as new customers visiting our booth, this was the platform where all the prospects could reach us and we could demonstrate our technologies to them.”

**Rishi Kapoor**  
Associate Vice-President &  
Country Head  
Meiban Engineering  
Technologies

and enhance precision.

Sachin Sinha, Founder & Director, Tecroot Space OPC (P) Ltd, presented a visitor's perspective, “DMTX 2025 is a clear indication that the Manufacturing industry shows all the signs of moving rapidly towards smart factories to redefine the 21<sup>st</sup>-century industrial revolution.”

With outcomes of strong business and lead generation, leading companies like AceMicro-matic, Jyoti CNC, UCAM, Meiban Engineering, and more reported high-quality visitors, hundreds of leads, and multiple confirmed orders, validating DMTX as a serious business platform.



Source: Jyoti CNC Automation

Underscoring strong policy collaboration and export focus, IMTMA has formed a special export group to close global capability gaps and align Indian production with international demands—aiming to grow India's machine tool presence not just domestically but globally.



“Despite the current geopolitical tensions impacting overall turnout, DMTX 2025 was a well-organized event with high quality of visitors. We witnessed keen interest in our high-precision rotary tables, particularly the 4<sup>th</sup> axis models.”

**Vijay Zaritlikar**  
National Sales Manager  
UCAM Pvt Ltd

“Starting from CNC machine tools and cutting tools to peripheral systems like oil filtration units, mist filtration units, high-pressure systems, tool setters, etc., all the solution providers are integrating IoT systems into their products,” he remarked. “And that perfectly matches with what the component manufacturers are

looking for to make their factories future-proof and ready to serve customers globally.” Highlighting key showcases that stood out, he shared, “SF Hawk demonstrated its smart manufacturing capabilities through the VAJRA solution, which supports CNC machine users with OEE (Overall Equipment Effectiveness) and traceability. SRB Machines showcased its ‘Made in India’ CNC grinding machines, while AceMicromatic Group highlighted its advanced machining technologies with a strong emphasis on Factories of the Future and engineering excellence.”

**Validating Indian Engineering**

An enriching interaction was held around the Omnibus Technical Regulations (OTR) and the upcoming Capital Goods Policy, where Mittal urged, “If we’re able to create some niche in fields such as electronic machine manufacturing, advanced chemistry, and cell manufacturing technologies, we can bring a better trade balance in the near future.” Echoing the importance of aligning with national policies, Dasgupta opined, “All the major economies in the world are coming here and setting up their plants. As Indian machine tool builders, we must equip ourselves



“DMTX 2025 served as an effective platform for networking with industry professionals and decision-makers. The diverse visitor base, including representatives from various industry sectors, contributed to the dynamic atmosphere at our booth.”

**Manoj Kumar**  
Regional Head - Delhi  
LMW Ltd

to meet international standards. Our current domestic market share hovers around 45-50 percent, which we need to increase by upgrading capabilities and ensuring we meet global standards. Hence, the joint collaboration and the partnership that we have with the MHI and other ministries in Government of India are



Source: Magic Wand Media



Indian Machine Tool  
Manufacturers' Association



**FACTORIES OF TOMORROW**

-  **BUILD**
-  **MAINTAIN**
-  **UPGRADE**

**FACTEQ<sup>®</sup> 2026**  
Factory Equipment Expo

**21 - 24 May 2026**

Pune International Exhibition and Convention Center, Moshi, Pune

[www.facteq.in](http://www.facteq.in)

**BOOK YOUR SPACE TODAY**

Contact: Nishant Singh  
Mob: +91 9823174010, Email: nishant@imtma.in

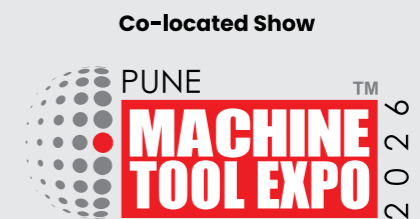

For enquires: [info@facteq.in](mailto:info@facteq.in)

[www.facteq.in](http://www.facteq.in)

Follow us on: 

At DMTX, a very clear shift toward IoT-enabled machines, automation, and smart factory systems was observed, with exhibitors and visitors aligning around Industry 4.0, digital transformation, and next-generation manufacturing technologies.



“We received a healthy mix of visitors—from decision-makers at large OEMs to MSME business owners—indicating strong interest across segments. We recorded a significant number of qualified inquiries, especially from NCR and neighboring regions.”

**Vikas Soni**  
Regional Manager - Sales  
Jyoti CNC Automation Ltd

highly crucial going forward.” Rajamane echoed this view, “IMTMA and MHI have been collaborating on several fronts. We’d like to thank MHI for continuing to support this industry with various schemes and initiatives.” Stressing the need for R&D coupled with India-first thinking and identifying global gaps, he

added, “Our collaboration with Advanced Manufacturing Technology Development Centre (AMTDC) in IIT Madras, has propelled a technological advancement in the Machine industry.” Speaking about the association, the IMTMA President remarked, “IMTMA, as the apex body for the Machine Tool industry in India, plays a vital role in its growth and development. The association actively engages in policy advocacy, organizes trade fairs, promotes exports, and drives technology missions. Skills are another criterion that is critical in today’s manufacturing, for which we have a dedicated skill upgrading center.”

**Platform with a Purpose**

Co-located with the second edition of FACTEQ, the fifth edition of DMTX brought the latest technologies to the doorstep of Northern India’s industrial ecosystem. Through key displays, strategic dialogues, and dealer-developer discussions, the event captured the essence of India’s manufacturing ambition and furthered the vision of ‘Atmanirbhar Bharat’. Moving forward with clarity and purpose, stakeholders are building on their experience to gear up for an even more impactful edition. As the Joint Secretary of the Ministry of Heavy Industries aptly noted,



“The manufacturing industry shows all the signs of moving rapidly towards smart factories to redefine the 21st-century industrial revolution. All the solution providers are trying their best to integrate IoT systems into their products.”

**Sachin Sinha**  
Founder & Director  
Tecroot Space OPC

“The real contribution is not only what we manufacture as a machine, but the multiple times of growth of the products manufactured out of those machines.” This multiplier effect—driven by innovation, policy collaboration, and indigenous excellence—is precisely what DMTX seeks to accelerate.



Source: Melban Engineering



Indian Machine Tool  
Manufacturers’ Association



The Region's Biggest Machine Tool Expo

**21 - 24 May 2026**

Pune International Exhibition and  
Convention Center, Moshi, Pune

[www.mtx.co.in](http://www.mtx.co.in)

Follow us on:

Powered by **IMTEX**

**BOOK YOUR  
SPACE TODAY**



# POWERING THE FUTURE OF MANUFACTURING IN INDIA

At the upcoming Symposium on Automation & Robotics 2025, innovation meets implementation as robotics and smart manufacturing take centre stage in shaping the future of India's manufacturing landscape.



Source: Magic Wand Media

Themed 'Trends and Insights for Tomorrow: Shaping the Future', the symposium will shed light on the trends in automation and robotics. Eminent speakers from various parts of India will present the emerging trends and developments in multiple facets of automation and robotics in manufacturing.

Indian Machine Tool Manufacturers' Association (IMTMA) is all set to organize the 8<sup>th</sup> edition of its flagship mega event, Symposium on Automation & Robotics (Conference and Exhibition) from June 4-5, 2025 at Auto Cluster Exhibition Center, Pune.

Themed 'Trends and Insights for Tomorrow: Shaping the Future', the symposium will shed light on the trends in automation and robotics.

Mr. Anand Deodhar, Group Chief Information Officer, Force Motors Ltd, will be the chief guest. Mr. Yuki Kita, Chief Executive Officer, Fanuc India, and Dr Asim Tewari, Professor (HAG), Center for Machine Intelligence and Data Science (C-MINDS), IIT Bombay will be the guests of honour at the inauguration.

Eminent speakers from vari-

ous parts of India will present the emerging trends and developments in multiple facets of automation and robotics in manufacturing.

Speaking about the upcoming edition, Jibak Dasgupta, Director General & CEO, IMTMA, said,

Stressing on the importance of the symposium, he added, "The symposium celebrates excellence, recognizing companies that exemplify automation-led performance. Participation at this event promises more than knowledge as it offers a glimpse into the fu-

### Event Details

- **Symposium on Automation & Robotics 2025**
- **Dates: June 4-5, 2025**
- **Location: Auto Cluster Exhibition Center, Pune**

"India's manufacturing landscape is changing with the advent of new and emerging technologies. Automation and Robotics are playing an enabling role and it is time for every industry from micro to large to explore deploying automation and robotics in their manufacturing lines to gain the global advantage."

ture of Indian manufacturing, one where machines and minds move in perfect harmony."

To sum up, the overwhelming response to the Symposium's eighth edition indicates the growing importance of automation and robotics in the Indian manufacturing realm. 

Source: IMTMA

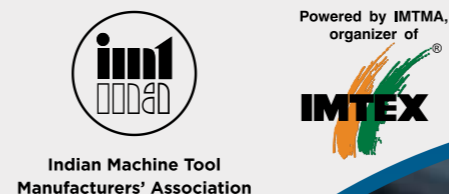

8th Edition

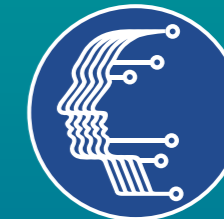

## SYMPOSIUM ON AUTOMATION & ROBOTICS CONFERENCE & EXHIBITION

4 - 5 June 2025

Auto Cluster Exhibition Center, Pune



### RETROSPECT

 <b>7</b> EDITIONS	 <b>100+</b> SPEAKERS
 <b>850+</b> PARTICIPATING COMPANIES	 <b>3,000+</b> PARTICIPANTS

### EVENT PREVIEW

 <b>3+ INSPIRING KEYNOTES</b>	 <b>30+ LEADING EXHIBITORS</b>	 <b>30+ EMINENT SPEAKERS</b>	 <b>1500 (300 Delegates + 1200 Visitors)</b>
---	--	--	--

## Trends & Insights for Tomorrow: Shaping the Future

This symposium provides the perfect solutions to your needs in manufacturing processes.

For more details, contact: prabhu@imtma.in ; Ph: 9980432663  
madan@imtma.in ; Ph: 7899437625

[www.imtma.in/automation](http://www.imtma.in/automation)

## A PLATFORM BEYOND SMART MANUFACTURING

Organized by the Ambattur Industrial Estate Manufacturers' Association (AIEMA), ACMEE 2025 will take place from June 19-23, 2025, at the Chennai Trade Centre, Chennai. The event, recognized as India's leading biennial exhibition on machine tools, automation, and industrial technology, is expected to gather top global and domestic industry leaders to showcase cutting-edge innovations and advanced solutions.



Source: Magic Wand Media

**W**ith the Manufacturing industry undergoing a strong digital shift, the significance of the 16<sup>th</sup> edition of ACMEE, a Union of International Fairs (UFI) approved international trade fair, is garnering nationwide interest. The theme, 'Beyond Smart Manufacturing,' places a bold emphasis on emerging technologies such as automation, robotics, IoT, Industry 4.0,

artificial intelligence, and digital manufacturing.

### ACMEE 2025 Highlights

The exhibition spans about 30,000 sq mt and is expected to gather more than 50,000 visitors this year. According to PS Ramesh, Chairman, ACMEE 2025, the event will host 500 exhibitors, including around 60 international participants hailing from various countries—exhib-

iting either directly or through local partners in India.

Attendees will have the opportunity to meet global leaders from the Machine Tool industry and witness live demonstrations and presentations of advanced technologies and products aimed at improving productivity and efficiency.

### Business Beyond Booths

A well-rounded lineup awaits

"The scale and scope of ACMEE have grown immensely, now drawing industry professionals from all over Chennai and beyond. This year's focus on automation and robotics reflects a global shift towards smarter manufacturing, complemented by dedicated conferences and buyer-seller meets to encourage meaningful business connections."

**PS Ramesh**  
Chairman  
ACMEE 2025



Source: MWM

visitors, featuring technical sessions, an international networking program, supplier-buyer interactions, a buyer-seller meet, and a finance lounge. These activities promise a holistic experience—enriching knowledge of the latest in machine tools and manufacturing technology while offering valuable industry insight, practical knowledge, and expert guidance.

A dedicated AIEMA Pavilion will feature member companies showcasing their products, facilitating buyer-seller interactions.

### ACMEE Through the Eyes of Experts

Participating in the exhibition as a gold sponsor, K Soundhar Rajan, Chief Strategy Officer, LMW Ltd, shared, "Chennai is a critical market with major automobile manufacturers driving demand." The company has bigger plans to ensure a bigger impact this year, with a sharp focus on the city's booming Automotive sector.

Reflecting on a journey spanning two decades, Muralidhara Rao, Director, Ace Designers Ltd - Machining Centre Division, spoke with immense pride regarding the company's long-standing partnership with the exhibition, calling it a turning point. Rao credits the event as a source of innovation, recall-

ing how many of the company's flagship products were inspired by customer needs encountered through the exhibition.

Expressing similar sentiments, C Renganathan, Managing Director, Chennai Metco Pvt Ltd, shared that the company consistently finds value in participating in every edition—taking part has become a tradition of sorts. "It continues to grow with each edition," he noted, adding that the event is steadily building a reputation as a global platform.

Speaking on the opportunities, Anil Bharadwaj, Managing Director, Yamazaki Mazak India Pvt Ltd, emphasized that the exhibition offers more than just business leads. "It's a rare chance to connect directly with production engineers, maintenance managers, and factory personnel—people who often don't get to attend larger international expos," he added.

Having attended the last three editions, Varun Dev, Chief Executive Officer, UCAM Pvt Ltd, views the exhibition as a vital platform, stating, "ACMEE is where the real industry conversations happen." He further added, "It's one of the few shows where the entire supply chain—from system integrators to OEMs—comes together."

Circling back to Chennai and its

appeal as an automotive hub, Dharmendra Nautiyal, Managing Director, Prima Power India Pvt Ltd, emphasized that the event's location offers the ideal platform for the company to present its technologies tailored for the automotive sector.

### Artech 2025: The Smart Manufacturing Show

With the exhibition focusing on concepts such as automation and robotics, a concurrent event—Artech 2025, the first edition of a dedicated automation and robotics technology show—will be held in an exclusive hall. "Along with the exhibition, the two-day conference will feature speakers addressing the role of automation and robotics in the manufacturing industry," the Chairman of ACMEE 2025 explained.

Highlighting the relevance of the concurrent show, Satish Sadasivan, Managing Director, SCHUNK Intec India Pvt Ltd, emphasized that it brings a timely and necessary focus to the future of manufacturing. For companies not looking to adopt such technologies yet, he believes the show is worth attending to gain valuable insights into the possibilities of smart manufacturing. "Sooner or later, smart manufacturing will become a way of life," he concluded. 

India's premier biennial exhibition for machine tools, automation, and industrial tech, ACMEE 2025, is scheduled for June 19-23, 2025, at Chennai Trade Centre, Chennai. Spanning 30,000 sq mt, it will host 500 exhibitors and attract over 50,000 visitors, focusing on innovations in automation, robotics, IoT, and Industry 4.0.

NITYASREE  
KUMARASWAMY  
Correspondent  
Magic Wand Media  
nityasree@  
magicwandmedia.in



## Company Index

ACE Designers Ltd, AceMicromatic Group	30, 66, 76	Meiban Engineering Technologies Pvt Ltd	66
ADDITEC	42	Mitsubishi Materials Corporation	24
Aeschlimann AG	38	NN Combined Engineering Agencies Pvt Ltd (NNCEA)	38
Ahire Machine Tools Pvt Ltd	56	Northeastern University in Shenyang	18
Ambattur Industrial Estate Manufacturers' Association (AIEMA)	76	Paras Defence & Space Technologies Ltd	34
Chennai Metco Pvt Ltd	56, 76	Paul Horn GmbH	38
Dassault Systèmes	62	Prima Power India Pvt Ltd	76
Dassault Systèmes India	62	Renishaw Metrology Systems Ltd	46
Defence Research and Development Organisation (DRDO)	34	RV Forms & Gears	18
Deutsche Messe AG	56	Sandvik AB	24
Dihawag AG	38	SCHUNK Intec India Pvt Ltd	76
Fenwick and Ravi	56	Shenyang National Laboratory for Materials Science	18
German Machine Tool Builders' Association (VDW)	56	Sphoorti Machine Tools Pvt Ltd	56
Grind Master Machines Pvt Ltd	56	Sumitomo Electric Industries Ltd	24
IMTMA	06, 08, 12, 14, 66, 74	Tecroot Space OPC	66
Indian Space Research Organisation (ISRO)	34	The Ministry of Defence (MoD)	34
ISCAR Ltd (IMC Group)	24	The Ministry of Electronics and Information Technology (MeitY)	34
Jiangyin Xingcheng Special Steel Works	18	The Ministry of Heavy Industries	66
Jyoti CNC Automation Ltd	66	The Society for Applied Microwave Electronics Engineering and Research (SAMEER)	34
Kennametal Inc	24	The University of Science and Technology Beijing	18
Krebs & Riedel Schleifscheibenfabrik GmbH & Co KG	48	UCAM Pvt Ltd	66, 76
LMW Ltd	56, 66, 76	Utthunga	52
Market Research Future (MRFR)	24	VDMA India Services Pvt Ltd, German Engineering Federation (VDMA)	56
Max Planck Institute for Iron Research (Germany)	18	Yamazaki Mazak India Pvt Ltd	76

## Advertiser Index

AceMicromatic Group - Ace Designers Ltd - Machining Center Division - <a href="http://www.acemicromatic.net">www.acemicromatic.net</a>	07
ACMEE 2025 - <a href="http://www.acmee.in">www.acmee.in</a>	19
Addison & Co., Ltd - <a href="http://www.addison.co.in">www.addison.co.in</a>	09
Battliboi Ltd - <a href="http://www.battliboi.com">www.battliboi.com</a>	11
CHIRON Group - <a href="http://www.chiron-group.com">www.chiron-group.com</a>	23
EMO Hannover 2025 - <a href="http://www.emo-hannover.com">www.emo-hannover.com</a>	13
Eplan Software Pvt Ltd - <a href="http://www.eplan.in">www.eplan.in</a>	17
Extrude Hone India Pvt Ltd - <a href="http://www.extrudehone.com">www.extrudehone.com</a>	21
Hann Kuen Machinery & Hardware Co., Ltd - <a href="http://www.hardy-tw.com">www.hardy-tw.com</a>	29
IMTMA - FACTEQ 2026 - <a href="http://www.facteq.in">www.facteq.in</a>	71
IMTMA - IMTEX FORMING 2026 - <a href="http://www.imtex.in">www.imtex.in</a>	61
IMTMA - Manufacturing Technology Training - <a href="http://www.imtmaelearn.in">www.imtmaelearn.in</a>	65
IMTMA - Symposium on Automation & Robotics - <a href="http://www.imtma.in/automation">www.imtma.in/automation</a>	75
IMTOF 2026 - <a href="http://www.imtof.in">www.imtof.in</a>	15
Jyoti CNC Automation Ltd - <a href="http://www.jyoti.co.in">www.jyoti.co.in</a>	03
LMW - <a href="http://www.lmwncnc.com">www.lmwncnc.com</a>	02
Marposs India Pvt Ltd - <a href="http://www.marposs.com">www.marposs.com</a>	27
NN Combined Engineering Agencies Pvt Ltd - <a href="http://www.nncea.com">www.nncea.com</a>	80
PMTX 2026 - <a href="http://www.mtx.co.in">www.mtx.co.in</a>	73
Rajamane Industries Pvt Ltd - <a href="http://www.rajamane.com">www.rajamane.com</a>	10
Royal Precision Tools Corporation - <a href="http://www.royal-spindles.com">www.royal-spindles.com</a>	25
RV Forms & Gears LLP - <a href="http://www.rvformsandgears.com">www.rvformsandgears.com</a>	79
TAGMA INDIA - <a href="http://www.diemouldindia.org">www.diemouldindia.org</a>	45
Teledyne FLIR, LLC - <a href="http://www.flir.in">www.flir.in</a>	43
Tiending - <a href="http://www.tdcover.com">www.tdcover.com</a>	05



# SmartFix4.0<sup>®</sup>

## Intelligent Fixtures



Winner of CII Industrial Innovation Award 2020



## Asia's leading fixture builder

For over 50 years Forms & Gears has been designing and manufacturing Precision Fixtures to the world's leading Auto OEMs and Machine Makers in 10 countries across the globe.

**RV Forms & Gears LLP**  
 MF 11, SIDCO Industrial Estate, Guindy,  
 Chennai - 600 032, Tamilnadu, India  
 Call +91 77570 53326 or email us on  
[marketing@rvformsandgears.com](mailto:marketing@rvformsandgears.com)  
[www.rvformsandgears.com](http://www.rvformsandgears.com)



Yes, I wish to subscribe to **MODERN MANUFACTURING INDIA**

1 Year ₹ 750  
 2 Years ₹ 1200

### PERSONAL DETAILS

Company \_\_\_\_\_  
 Name \_\_\_\_\_  
 Department \_\_\_\_\_ Designation \_\_\_\_\_  
 Company Address \_\_\_\_\_  
 \_\_\_\_\_  
 City & Pin Code \_\_\_\_\_ Country \_\_\_\_\_  
 E-mail \_\_\_\_\_ Contact No. \_\_\_\_\_  
 Industry \_\_\_\_\_

### SUBSCRIPTION PAYMENT DETAILS

Please find enclosed cheque / DD No.: \_\_\_\_\_  
 Drawn on (Name of bank & branch): \_\_\_\_\_  
 Dated \_\_\_\_\_  
 For Rs. \_\_\_\_\_ Rupees in words \_\_\_\_\_

Favouring **INDIAN MACHINE TOOL MANUFACTURERS' ASSOCIATION**  
 IMTMA, Bangalore International Exhibition Centre (BIEC), 10<sup>th</sup> Mile, Tumkur Road, Madavara post, Bangalore - 562123  
 Tel: 080 - 66246617 [imtma@imtma.in](mailto:imtma@imtma.in)  
 Sources & Terms of Supply: Orders can be placed directly with the publisher. No claims for the supply of back copies or reimbursement of subscription fees can be entertained for non-delivery of the magazine for reasons beyond the publisher's control.

To SUBSCRIBE



[www.mmindia.co.in/magazine\\_issues](http://www.mmindia.co.in/magazine_issues)



# ULTRA-FINISH MACHINING FOR PINPOINT ACCURACY

## EXPLORE HORN

Exceptional performance comes from pairing the optimal machining process with the perfect tool. HORN combines cutting-edge technology with outstanding performance and reliability.



[horn-group.com](http://horn-group.com)

### Suppliers of Quality Products

*qual-i-ty* Consistent adherence to measurable and verifiable standards to achieve uniformity of output that satisfies specific customer requirements.

Contact Information:  
NN Combined Engineering Agencies Pvt Ltd  
First Floor Dr Ranji Block 125 M G Road Secunderabad 500 003 India  
Internet: [www.nncea.com](http://www.nncea.com) Email: [mail@nncea.com](mailto:mail@nncea.com)  
Phones: +91 (40) 27844279 / 27898579 / 48502475

**NN COMBINED  
ENGINEERING  
AGENCIES**  
PRIVATE LIMITED  
SUPPLIERS OF QUALITY PRODUCTS

