



MODERN
MANUFACTURING
INDIA

WWW.MMINDIA.CO.IN

The Official Magazine of



Indian Machine Tool
Manufacturers' Association

In Association with



IIOT: TRANSFORMING THE BUSINESS ECOSYSTEM

COUNTRY FOCUS:
JAPAN

28

MEDICAL
MACHINING

38



CARL MARTIN WELCKER
General Commissioner
EMO Hannover 2017

LARGEST CONSTRUCTION EQUIPMENT EXHIBITION IN SOUTH ASIA



12th - 16th December 2017 | BIEC, Bengaluru, Karnataka, India



HIGHLIGHTS

2,50,000 Sq.mts. of Exhibition Display Area	40,000+ Business Visitors from India & Abroad	200+ Product Launches	1000+ Exhibitors including 300 from abroad
---	---	---------------------------------	--

9 COUNTRY PAVILIONS CHINA, FINLAND, GERMANY, ITALY, SOUTH KOREA, SWEDEN, TURKEY, UK & USA	INDUSTRY CONFERENCES By CII, BAI and ICEMA	LIVE Demonstration on Advanced Technology
---	--	---

EVENT SPONSORS



ASSOCIATE SPONSORS



EXCON 2017 DESK

Confederation of Indian Industry (CII), Prof. C K Prahalad Center, Trade Fair Department, No.98/1, Velachery Main Road, Guindy, Chennai-600 032, INDIA
Tel: +91-44-42444520 | Mobile : +91-97898 08994, Email: excon@cii.in | Website: www.excon.in | www.cii.in



AEROSPACE



ENERGY

AUTO
MOBILE



DEFENCE



INFRASTRUCTURE



HEALTHCARE



TEXTILE



OIL & GAS



PUMPS & VALVES

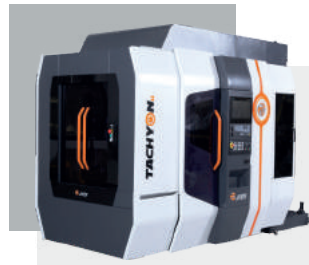

Tachyon 7
CNC High Speed Vertical Drill Tap
Centre



ATM 160
CNC Inverted Vertical Spindle
Turn Mill Centre



TMX 200
CNC Twin Spindle Twin Turret
with Y-Axis



VTL 750
CNC Vertical Turret Lathe



HX Series
CNC Horizontal Machining Centre



HSX Series
CNC High Speed
Horizontal Machining Centre

JYOTI CNC AUTOMATION LTD.

G - 506, G.I.D.C. Lodhika, Village : Metoda, Dist : Rajkot - 360021, Gujarat (INDIA).

T + 91-2827-306100/101, E info@jyoti.co.in, sales@jyoti.co.in

jyoti.co.in

Visit us at

EMO
Hannover

18-23.9.2017

Hall 27, Booth D70/D78

CONTENTS

VOL 1, ISSUE 2, JULY 2017

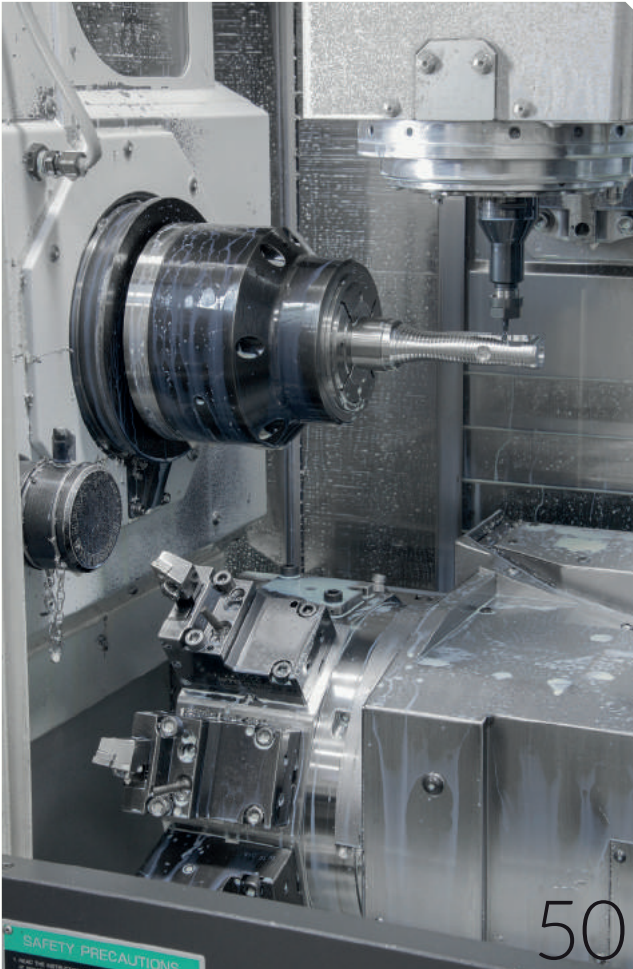

06	FOREWORD
08	PUBLISHER'S NOTE
10	EDITORIAL
12	IMTMA'S DESK
14	PANORAMIC PERSPECTIVE
16	NEWS
18	COVER STORY IIoT: Transforming the Business Ecosystem
24	BIG INTERVIEW Carl Martin Welcker General Commissioner EMO Hannover 2017
28	COUNTRY FOCUS India-Japan: Untapping the Potential through Synergy
32	COMPANY PROFILE Raising the Bar
34	INDUSTRY VIEWS Implications of GST
38	MEDICAL MACHINING For a Good Cause
40	ADDITIVE MANUFACTURING Can 3D Printing Increase Milling Feed Rates?



58

- 42 **INDUSTRIAL WASTE MANAGEMENT**
Chip Compacting:
Making the Best Out of Waste
- 46 **AUTOMATION & CONTROL**
Ensuring Maximum Productivity
- 48 **INDUSTRIAL PARTS CLEANING**
Snow-Jet Technology:
For Ideal Coating Results
- 50 **BEST PRACTICES**
Making Life-Changing Devices
- 54 **SAVE THE DATES**
- 55 **EVENT SNAPSHOT**
INTEC 2017:
A Window of Opportunities
- 58 **EMO PRESS PREVIEW**
A Glimpse of EMO 2017
- 64 **EVENT PREVIEW: NPS**
Conquering the Summit
- 66 **EVENT PREVIEW: DMTX 2017**
An Impetus to the Manufacturing Sector
- 70 **COMPANY / ADVERTISER INDEX**

IMPRINT

**PUBLISHER &
DIRECTOR GENERAL & CEO, IMTMA**
V Anbu

EDITORIAL
Editor-in-Chief
Soumi Mitra

Chief Copy Editor
Poonam Pednekar

Senior Correspondent
P K Chatterjee

Head Creative & Production
Shanmugam Pillai (Som)
Snehal P

SALES & MARKETING
Indian Machine Tool Manufacturers'
Association (IMTMA)
Magic Wand Media Inc

Published and Printed by V Anbu on behalf of Indian Machine Tool Manufacturers' Association. Printed at Pentaplus Printer's Pvt Ltd 20/1, 4th main, 5th cross, Industrial Town, Rajaji Nagar, Bangalore-560044, Karnataka and Published from Indian Machine Tool Manufacturers' Association; Head Office : 10th Mile, Tumkur Road, Madavara Post, Bengaluru - 562123, Karnataka. Editor: Soumi Mitra

Publishing frequency: 6 times per year

Manuscripts: No liability is accepted for unsolicited manuscripts. They will be returned only if accompanied by sufficient return postage.

All rights reserved. Reprints, digital processing of all kinds and reproduction only by written permission of the publisher. Any views, comments expressed are the sole responsibility of the respective authors, IMTMA and Modern Manufacturing India and its partners do not undertake any responsibility, implied or otherwise.

Disclaimer: Every effort has been taken to avoid errors or omissions in this magazine. In spite of this, errors may creep in. Any mistake, error or discrepancy noted may be brought to our notice immediately. It is notified that neither the publisher, the editor or the seller will be responsible in respect of anything and the consequence of anything done or omitted to be done by any person in reliance upon the content herein. This disclaimer applies to all, whether subscriber to the magazine or not. © All rights are reserved. No part of this magazine may be reproduced or copied in any form or by any means without the prior written permission of the publisher. All disputes are subject to the exclusive jurisdiction of competent courts and forums in Bangalore only. While care is taken prior to acceptance of advertising copy, it is not possible to verify its contents. IMTMA cannot be held responsible for such contents, nor for any loss or damages incurred as a result of transactions with companies, associations or individuals advertising in its newspapers or publications. We therefore recommend that readers make necessary inquiries before sending any monies or entering into any agreements with advertisers or otherwise acting on an advertisement in any manner whatsoever.



PG JADEJA
President
Indian Machine Tool Manufacturers' Association (IMTMA)

FUELING MANUFACTURING GROWTH

Welcome once again to Modern Manufacturing India (MMI) magazine July 2017 edition.

The much talked about tax reform in the country – the Goods and Services Tax (GST) came into effect from July 1. The new paradigm in India's cooperative federalism is expected to bring marked improvement in tax compliance and facilitate the ease of doing business. The applicability of the standard GST 18 percent rate for machine tools may result in reduction in overall indirect tax.

IMTMA, to build up on the current economic scenario and bright economic prospects, is organizing the 11th edition of the National Productivity Summit on August 04-05, 2017 in Pune. The Summit brings out why manufacturers should embrace an integrated approach to optimizing manufacturing productivity and how to prepare their workforce, processes and technology for productivity excellence.

The Association will also organize the second edition of the Delhi Machine Tool Expo (DMTX 2017) from August 10-13, 2017 in New Delhi. DMTX 2017 also focuses on Metrology and Welding. METROLOGY EXPO, an exhibition for testing instrument, metrology and equipment and WELDEXPO, an exhibition for welding, cutting and joining, will be held concurrently.

IMTMA will continue organizing a wide range of training programmes at its Technology Centers in Bengaluru, Gurugram and Pune to hone the skills of the manufacturing industry's workforce.

The new industrial Policy likely to be released this year is expected to put Indian manufacturing industry on the global map.

With this note of optimism, I call upon the industry to wholeheartedly support Association's initiatives by giving valuable feedback which will help us in our journey to strengthen the Indian manufacturing sector. Readers can also download previous issue of the magazine from IMTMA website.

Happy reading.

PG Jadeja
President
Indian Machine Tool Manufacturers' Association

- ◆ Advanced Technologies for the Next Generation
- ◆ Solid Support for Day-to-Day Comfort
- ◆ Optimum Solution for the Future

MITSUBISHI ELECTRIC CNC Solution The Best Partner for Your Success

Our single goal is to minimize the downtime while maximizing the productivity of every Mitsubishi Electric product. The more time you spend using our products, the better your business runs.



This is the MITSUBISHI CNC business philosophy. All the staffs who are committed to MITSUBISHI CNC business wish to be “the best partner for customers aiming at global and future-oriented development”. We will continue our efforts with the aim that our CNCs be great help to the customers.

Contact

Mitsubishi Electric India Pvt. Ltd.

CNC Technical Centre, Plot No. 56, 4 Main Road, Phase 3
Peenya Industrial Area, Bangalore-560058, Karnataka.

Tel.: +91(80)465 52121, Fax.:+91(80)465 52147





Dear MMI Readers,



Modern Manufacturing India (MMI) magazine has had a grand beginning. Our widely circulated bimonthly magazine has been well-accepted by the global manufacturing fraternity and serves as a reading lens to the manufacturing world that is constantly undergoing changes with technology replacing labor.

India is witnessing some rapid changes in the manufacturing landscape. The country is embracing new technologies and innovations that would spur manufacturing industry to greater heights and position it firmly on the global map.

This month's edition carries insightful and informative articles on machine tool and manufacturing industry. Read on for a quick peek into a special article by IMTMA on how Industry 4.0 will shape manufacturing and open up a plethora of opportunities to place the Indian machine tool industry on the global radar.

The Indian machine tool industry has welcomed this initiative of IMTMA with open arms. The Association has been encouraged by the positive feedback for the many iterations made to make the content more exciting including the typefaces and page designs.

IMTMA is excited to continue bringing valuable content to enable the machine tool industry to achieve the widest possible reach and create an impact at the global level.

Any publishing process is incomplete without feedback from readers, and therefore we solicit your valuable thoughts to make our MMI more insightful and interesting. This will also enable our young magazine to mature in stature.

As always, I hope you enjoy the time you spend with MMI and thank you once again for your support.

Warm regards,

V ANBU
Director General & CEO
Indian Machine Tool Manufacturers' Association

Precision Machines.

Reliable
Performance.

Largest Manufacturers of
3 axes, 4 axes & 5 axes
CNC Machining
Centers...



We understand complex shapes and exotic materials can be a real challenge to machine without the use of right products.

With AMS's multitasking and 5 axes machining centers you can address these issues while raising the productivity levels.

Our products are handcrafted to suit aerospace parts machining while they are also designed for high dynamic performance.

ACE MANUFACTURING SYSTEMS LTD.

Plot No. 467 - 469, 4th Phase, Peenya Industrial Area, BANGALORE - 560 058. INDIA.,

T: +91-9880189832 E: helpdesk@amslindia.co.in

www.amsl.in

VISIT US AT



10th August to 13th August, 2017

Hall - 11
Stall - B 103

NO TIME LIKE THE PRESENT...



Soumi Mitra

SOUMI MITRA
Editor-in-Chief
Modern Manufacturing India
soumi.mitra@magicwandmedia.in

At the outset, I wholeheartedly thank you, “our valuable readers”, for your encouraging words on the refreshed version of MMI. Your continued support and faith provide us the confidence to recognise opportunities coming our way and make the best of them while reaching out to a wider global audience.

A few weeks ago, I had the privilege of being part of the EMO Press entourage and getting a sneak peek into the latest production technologies to be showcased at the event from Sept 18–23 in Hannover.

A 25 percent rise in Asian participation gives an interesting twist to the 2017 edition of the show. It will, quite possibly, be breaking all its records in terms of participation.

That a day has been dedicated to focus solely on India’s competence in mechanical engineering and capital investment, reiterates the potential India holds in the global market and gives us another reason to look forward to the show.

People will try to tell you that all the great opportunities have been snapped up. In reality, the world changes every second, blowing new opportunities in all directions, including yours.

~KEN HAKUTA

The current issue celebrates India’s prowess in manufacturing and highlights advanced manufacturing technologies that present a mega opportunity to the country to yet again demonstrate its leadership in the field.

Wish you an insightful read!

READER’S CORNER



“The look and feel of the new avatar of MMI comes across as fresh. The font, its depth, and the shade of blank ink all contribute to make it highly readable, especially for old people like me! I found the content quite informative. The case study on Volvo about 3D Printing sheds light on the latest trends in the industry. I look forward to such topics and on how different industries influence the machine tool sector.”

**N K Dhand, Chairman,
Micromatic Grinding Technologies
Past President, IMTMA**



“I am much impressed with TK Ramesh’s write-up that appeared in Modern Manufacturing India May issue. His advice to people of the industry to be cautious in changing operational practices in a changed environment is apt and timely. I shared this nugget of wisdom with my colleagues and my mentors to acknowledge their efforts to ‘Teach and Train’ us.”

**Narasinh K Balgi, Director,
Ferromatik Milacron India Ltd**

India's Premier International Machine Tools Show

ACMEE 2018
13th INTERNATIONAL MACHINE TOOLS EXHIBITION



An AIEMA Initiative

21 - 25 June 2018

CHENNAI TRADE CENTRE, CHENNAI, INDIA

ORGANISED BY



TITLE SPONSOR



www.acmee.in

PLATINUM SPONSORS



GOLD SPONSORS



SILVER SPONSORS

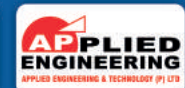



INDUSTRY 4.0: TO MAKE INDIA A MANUFACTURING POWERHOUSE

In its consistent efforts towards zero-defect, increased productivity goals, the Indian manufacturing industry is embracing smart technologies that herald an era of unprecedented benefits.

The manufacturing industry of India will derive optimum benefits from technologies that connect systems for intelligent production. Technologies that enable Industry 4.0, capturing data and data sources, communicating data between machines, sensors and data sources, 3D printing, robots and systems such as Internet of Things (IoT) have made manufacturing 'smart'. Indian companies are embracing these technologies and investing in the fourth industrial revolution (Industry 4.0) just as any other major economy of the world. The

changes that machine tool manufacturing industry is witnessing in terms of scale and magnitude for increasing its productivity through Industry 4.0 is one which has never been experienced before.

Why the need for Industry 4.0

To begin with, companies initially focused on mass production and customized production. Now customers are demanding for customized production in mass. This necessitates production system and processes to be flexible and smart. Moreover, when production becomes capital intensive, the labor

cost advantages of traditional locations shrink and Industry 4.0 becomes vital.

Relevance of Industry 4.0

Customers today demand for zero defect products and it is difficult for manufacturing industry to satisfy the demands of customers without embracing smart technologies. Industry 4.0 is relevant in this as it enables the industry to produce zero defect products besides increasing productivity. As the industry upgrades its machinery to modern ones which are compatible with Industry 4.0 we would see productivity levels scaling up.

Customers' demand for customized production in mass necessitates production system and processes to be flexible and smart.

India and Industry 4.0

Indian companies are offering first generation 4.0 solutions. An awareness is being built up on smart manufacturing throughout the industry workforce. Many individual companies are adopting advanced ERP systems which monitor production process in more detail and generate data for the management on real-time basis. Many companies in auto component and automobile sector are shifting to Industry 4.0. in production process.

Smart manufacturing

Smart manufacturing is envisioned as the future of manufacturing. It is a process that integrates human ingenuity with data and technology to revolutionize the development and application of manufacturing intelligence to all aspects of a business. To develop smart manufacturing and build intelligence in business processes, Indian Machine Tool Manufacturers' Association (IMTMA) organizes a symposium on Smart Manufacturing in Bangalore. The symposium acts as a forum to address the queries and challenges in this area. Two Symposiums on Smart Manufacturing have been organized by IMTMA in 2016 and 2017.

Roadmap for future

The industry can leap forward with smart manufacturing. Industry leaders must provide a direction in this. In terms of cost and adapting to new systems, a phased approach will be practical. Companies need to assess the overall manufacturing facilities, plant integration, plant-wide optimization and manufacturing intelligence and knowledge for business



National Productivity Summit 2017

Companies are being constantly challenged to increase competitiveness in manufacturing to increase their growth, reduce cost of operations, enhance productivity and thereby, build a sustainable competitive advantage. With the growing merger of physical and digital manufacturing worlds, technological advancement is becoming a key facilitator in this pursuit. Companies need to adopt a highly structured approach to manage innovation, while at the same time, not losing out on time to reach the markets.

To champion the cause of productivity and enhancing competitiveness in the Indian manufacturing industry, IMTMA is organizing the 11th edition of the National Productivity Summit on August 04-05, 2017 in Pune.

The summit will showcase the best practices in manufacturing. It will have inspiring keynotes from eminent speakers, seven case study presentations by manufacturing companies contesting for the IMTMA-ACE Micromatic Productivity Championship Awards 2017, and three plant visits to Spicer India & Bosch Chassis Systems India, Cummins India & Tata Cummins, and Mahle Behr India & Concentric Pumps to witness how productivity improvement projects are being translated into action. The Productivity Championship Awards will recognize and reward outstanding efforts from the shortlisted case studies of companies who have excelled in achieving superior performance and give cash prizes worth ₹10 lakh.

transformation. This will enable the Indian manufacturing industry to become globally competitive.

Government support

Recognizing the importance of smart manufacturing and Industry 4.0, the Government of India has been promoting Industry 4.0 through various seminars and stakeholder discussions for showcasing its relevance for the manu-



Delhi Machine Tool Expo 2017

IMTMA is organizing the second edition of its northern regional show, the Delhi Machine Tool Expo (DMTX) 2017, on August 10-13, 2017 at Pragati Maidan, New Delhi.

The expo will also focus on Metrology and Welding: METROLOGY EXPO, an exhibition for testing instrument, metrology and equipment; and WELDEXPO, an exhibition for welding, cutting and joining, will be held concurrently.

DMTX will showcase state-of-the-art technologies focusing on manufacturing solutions for metal cutting and metal forming industries located in North India. Focus will be on the large number of small and medium enterprises spread across the states including Delhi, Rajasthan, Haryana, Uttar Pradesh, Uttarakhand, and Himachal Pradesh.

Expressing his views about the expo, PG Jadeja, President, IMTMA, said, "North India has many industries, and is a hub for engineering and manufacturing. The first edition of the show held two years ago provided a common platform for manufacturers to expand their range. This show will also have presence from domestic and international machine tool manufacturers."

Concurring with Jadeja's views, V Anbu, Director General, IMTMA, added, "We expect a bigger level of participation and better footfalls for this edition from the region cutting across various industry sectors."

DMTX 2017 will feature over 200 exhibitors occupying a gross exhibition area of around 12,000 sq mt in three exhibition halls. Seven foreign countries (Czech Republic, Germany, Italy, the USA, China, Taiwan and Australia) are expected to participate.

facturing sector. The government is also committed to developing Industry 4.0 technology through national institutions such as CMTI and IITs, etc. The Department of Heavy Industry is also thinking of supporting Experience Centers for Industry 4.0 jointly with industry partners with multiple locations. 

ENCOURAGING FIDELITY IN BUSINESS

In the manufacturing B2B space, most of us believe our customers are loyal since we keep getting repeat business from them over time. It is also perceived that the capital equipment purchase in manufacturing is driven by the same sentiment because it is fairly common to see lines of machines from the same manufacturer. However, a different picture emerges when we seriously ponder over the noble quality of loyalty and its attributes.

Faithfulness in a relationship inherently implies adhering to the chosen one and not getting strayed by equally or more attractive options. The emotion is far from being logical. It is similarly irrational when an existing customer continues to do business with a company even when a cheaper, more convenient or even higher-quality machine is available from another. The decision of sticking to the same company, despite enough knowledge of a better offer, has more to do with the buyer than the seller.

There is a great divide between loyalty and repeat sales. Technology, price, aesthetics help influence the initial sales, whereas repeat sales happen due to familiarity, habit, and difficulties in switching. Repeat buying is a calculated move driven by sellers who sweeten the deal, making it difficult for the existing buyer to leave. Loyalty, on the other hand, is led by an emotional connect. It stems from the buyer's belief system and identity, which are deeply personal. He must be able to relate to the company's philosophy, its way of doing business and what it stands for.

Apple customers best exemplify the loyalty in question. While the price of any Apple product is at least 25 to 40 percent more than its competition's products that offer higher specifications in phones, tabs, note books and computers, Apple has no threat with regard to its customer base. They remain fiercely dedicated, having no qualms with fewer peripheral choices, difference in chargers, proprietary software etc. The decision to buy an Apple is emotional and owning it reflects a sense of identity.

Closer home akin to the Harley Davidson furor is our very own Enfield motorcycle following, which helps to reiterate that loyalty is more about a company's ability to express a distinct sense of why they exist and what they believe in rather than what they make or the quality of what they make. The clearer the belief, the greater the appeal of the company to those with similar beliefs.

From a Machine Tool perspective, the philosophy of service—standing with the customer in times of need, handholding him with a strong belief of customer support and practicing the belief across the company—drives loyalty. When put in practice, the company reflects an authentic belief system that will be supported by a loyal customer base.

The decision of sticking to the same company, despite enough knowledge of a better offer, has more to do with the buyer than the seller.

T K RAMESH
Whole time Director and CEO
Micromatic Machine Tools Pvt Ltd

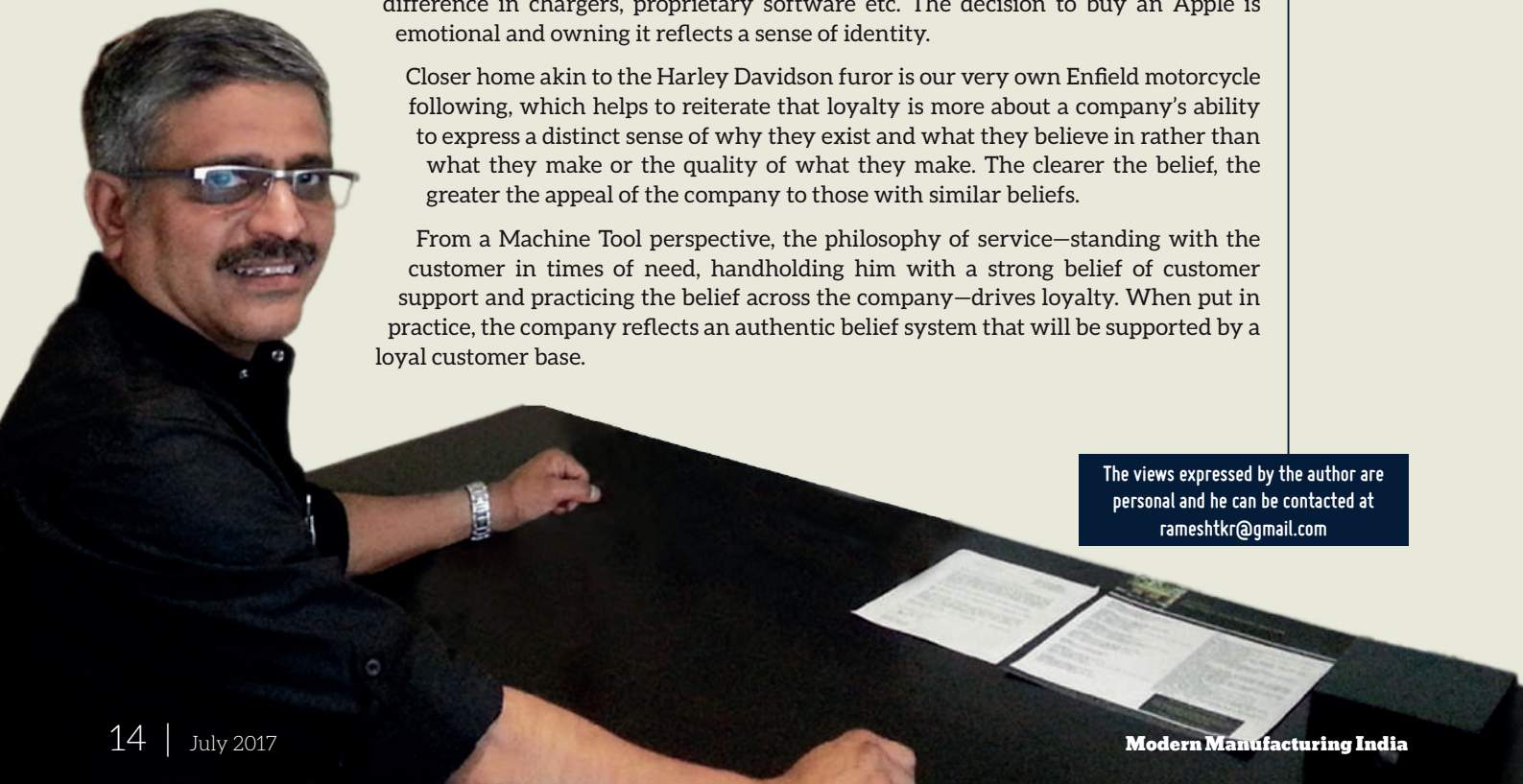

The views expressed by the author are personal and he can be contacted at rameshtkr@gmail.com

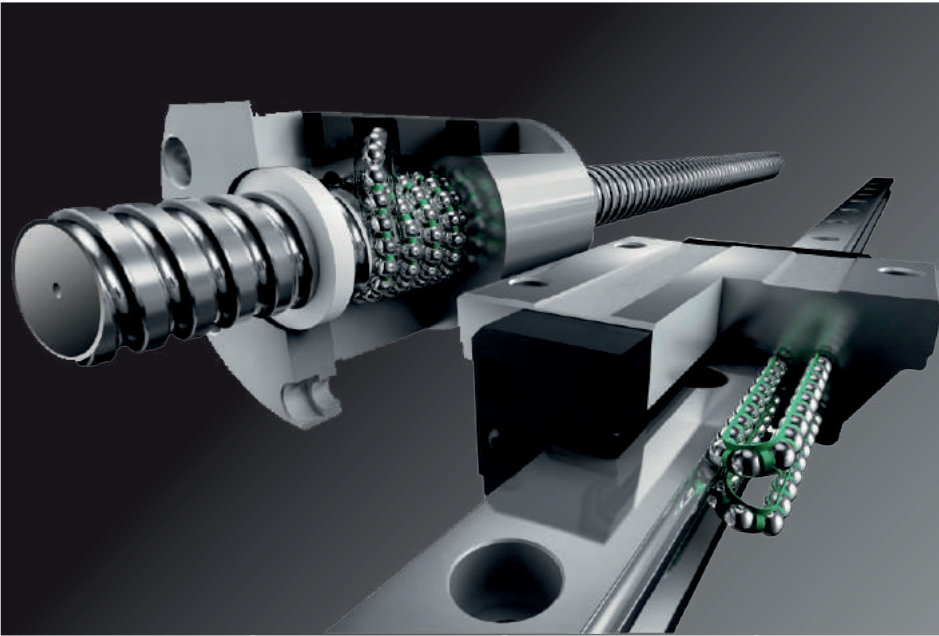

THK
The Mark of Linear Motion

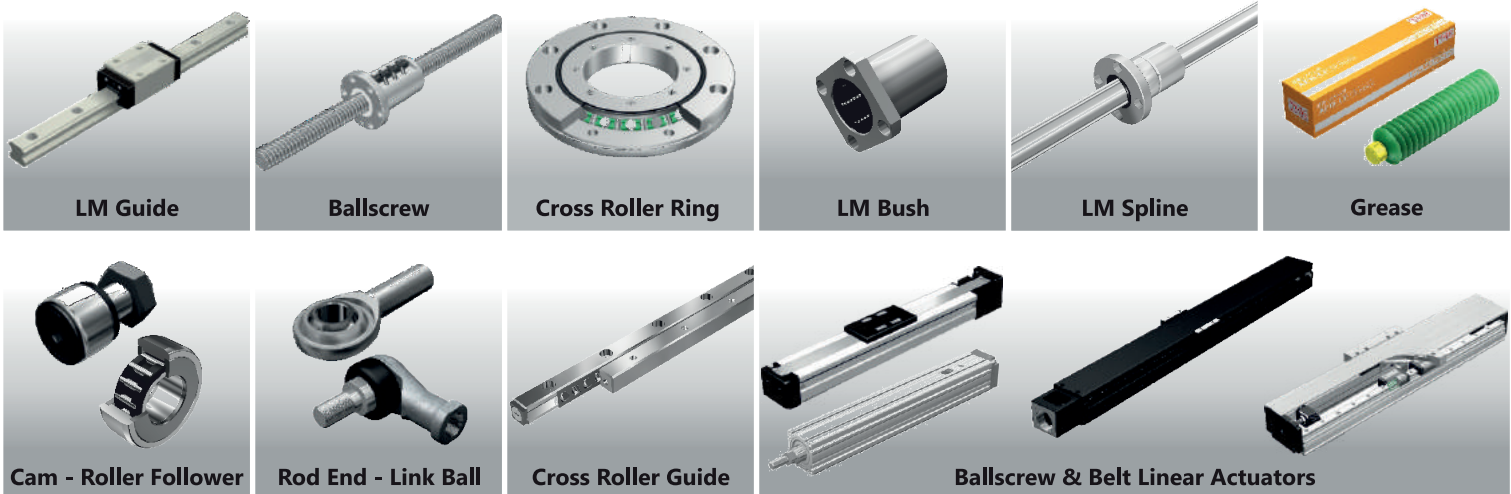

OUR OTHER PRODUCTS

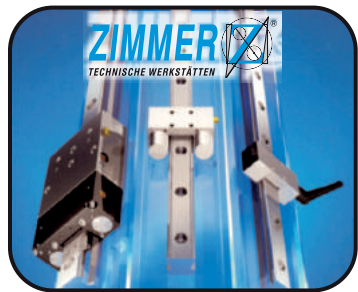

LM Guide Clamp



Curvic Coupling



Gear, Rack & Pinion



Ball Transfer Unit



Mist Cleaner



Large Diameter Ballscrew



Precision Planetary Gearbox



Locknut + Locking Element

APEX
PRECISION

Amcats Pvt. Ltd.
Apex Precision Mechatronics Pvt. Ltd.

303 - 308, Krishna Bhuvan Annexe, 22-B, Govandi Station Road, Deonar, Mumbai - 400088
Tel: +91 22 6146 4444 Email: sales@apexprecision.co.in URL: www.apexprecision.co.in
MUMBAI BANGALORE CHENNAI HYDERABAD AHMEDABAD



Manufacturing Sees Dip in Negative Growth

New Delhi, India - The manufacturing sector outlook shows improvement in the first quarter of the fiscal (April - June 2017-18) due to a rise in the percentage of respondents reporting higher production as compared to previous quarter, according to FICCI's latest Quarterly Survey. While the percentage of respondents reporting an improved output growth in the first quarter has increased from 47% (January - March 2016-17) to 49%, there is a dip in the reports of negative growth from 27% (the previous quarter) to 17% (April - June 2017-18). The survey assessed the manufacturers' expectations for 11 sectors - auto, capital goods, cement and ceramics, chemicals and fertilizers, electronics & electricals, leather and footwear, machine tools, metal and metal products, paper products, textiles and technical textiles, and textiles machinery.

US Cutting Tool Consumption Up

Cleveland, US - The US cutting tool consumption recently totaled to \$191.93 million according to the US Cutting Tool Institute (USCTI) and the Association for Manufacturing Technology (AMT). With a year-to-date total of \$908.04 million, 2017 is up 5.8% when compared with May 2016. "As domestic manufacturing growth is projected to continue, 2017 will be a much better year for the Cutting Tool Industry," said Brad Lawton, Chairman, Cutting Tool Product Group, AMT.

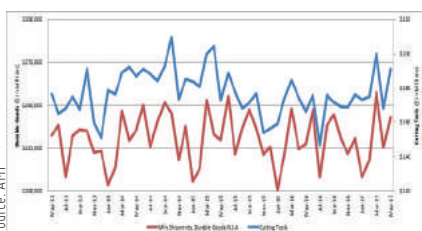

Saket Bhartia, Managing Director, Zavenir and Martin Kluthe, Managing Director, Kluthe Group (Germany) signing the MoU of the joint venture.

Source: Zavenir

Zavenir and Kluthe Group into JV

Gurugram, India - Zavenir and Kluthe Group have announced a major strategic 50:50 joint venture, named Zavenir Kluthe. The aim of this tie-up is to cater to the needs of Automotive, Automotive Ancillaries, Heavy Engineering, and Plastic Industry. Post tie-up, Zavenir will help the venture with its domestic infrastructure in marketing and sales of specialty chemical products. While, Kluthe, by sharing its state-

of-the-art technologies, will bring in competitiveness to users, apart from enabling them to adopt solutions which are greener. Since 2011, Zavenir has been a licensee partner of Kluthe Group. This joint venture is an extension of this relationship aimed at increasing manufacturing, marketing, and sales of all Kluthe's products and technologies in the field of metal working fluids, surface treatment, and paint shop management.

FAG Bearings India changes to Schaeffler India

Mumbai, India - FAG Bearings India Ltd, a leading manufacturer of industrial and automotive bearings, has changed its corporate name to Schaeffler India Ltd recently. The process of changing the company's name was completed after the required regulatory and subsequent shareholder approvals were obtained. This change of name is an important step in the rollout of the new global strategy "Mobility for tomorrow" of the company's parent group, Schaeffler AG, a global automotive and industrial supplier. "By adopting the Schaeffler name, we aim to unite and strengthen the Schaeffler brand both internally and externally in order to increase awareness and enhance our corporate profile in India," said Dharmesh Arora, CEO, Schaeffler India.



Source: Schaeffler

From compact to complex: The scalable Beckhoff CNC.



Industrial PC



I/O system

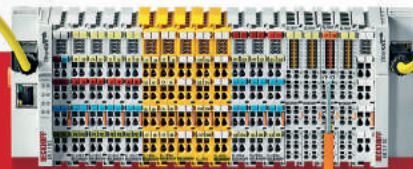

Servo drives

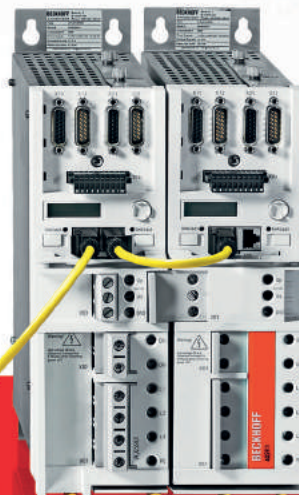

www.beckhoff.co.in/cnc

PC-based controllers from Beckhoff cover the whole range of high-precision CNC applications, from compact to complex.

- Highly scalable: the TwinCAT software platform for engineering and runtime
- Highly scalable: the Industrial PC range with processors from Intel® Atom™ to many-core
- Highly scalable: the I/O system for all signals and fieldbus systems
- Highly scalable: the highly dynamic servo technology for all performance classes
- Highly scalable: the safety solution, from system-integrated I/Os to drives



POWERING YEAR 10

Beckhoff Automation Pvt. Ltd.
Pune – 411 006, India
Phone: +91 20 40 00 48 00
info@beckhoff.co.in

New Automation Technology

BECKHOFF

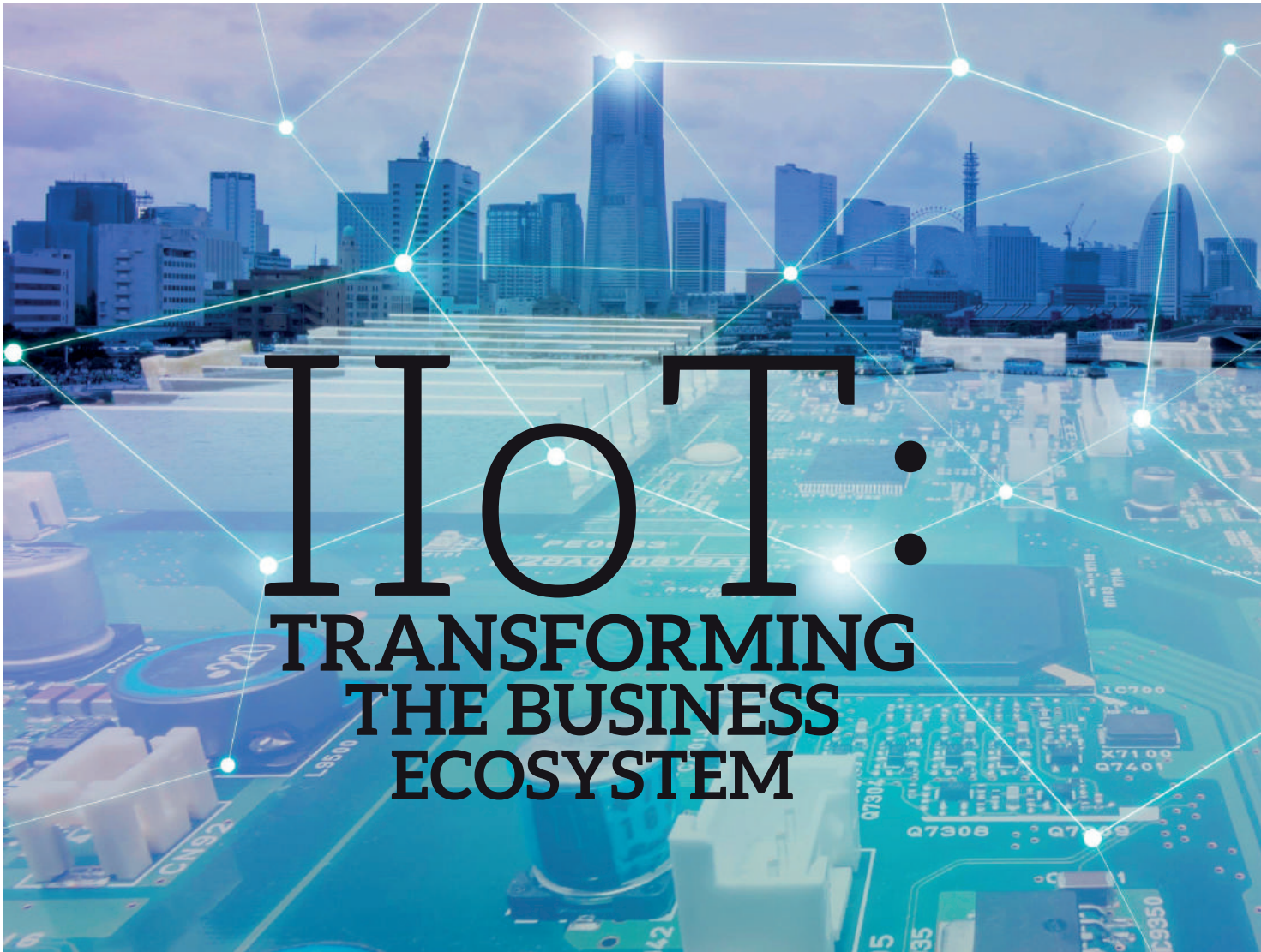

Source: Fraunhofer IPA

Current trends in production such as digitization, including the shift to mass personalization, lead to significant changes in manufacturing. The stages of digital transformation in the framework of the Industry 4.0 concept have a long history starting with mechatronic systems leading to cyber-physical and eventually autonomous systems to the final degree of autonomization. The traditional automation pyramid is thus dissolving.

PROF DR THOMAS
BAURNHANSL
Director - Fraunhofer
Institute for
Manufacturing
Engineering and
Automation IPA and the
Institute of Industrial
Manufacturing &
Management IFF -
University of Stuttgart
thomas.baurnhansl@
ipa.fraunhofer.de



The revolutionary aspect of Industry 4.0 is not digitization itself, but the ability to network technical systems in real time. Machines, sensors, tools, orders and people

can communicate via the Internet without time delays or barriers. Cyber-physical systems (CPS) are the core technology of Industry 4.0. The key structural elements include

an innovative user interface for integrating human beings into the process, the digital shadow (a virtual real-time image of reality) and software services which generate added value. It



also incorporates cloud-based platforms which support communication, a life cycle environment for physical systems and software services and analytical tools based on big data and machine learning. CPS use data from the Internet of Everything - the Internet of people, things and services.

Real-time integration is the key

The development of digitization started with mechatronic systems in the 1950s including, for instance, digital imaging of analogue processes or

computerized numerical control (CNC) technology. In the 1970s, it was joined by computer-aided design (CAD) and enterprise resource planning (ERP) and others. The first tentative steps towards developing Industry 4.0 can be found in the computer-integrated manufacturing (CIM) strategies of the 1980s. However, in those days, the necessary technologies were not available and there was a widely held belief that centralized controls were essential. At that time, designers envisaged humans being removed from the factory alto-

Technologies revolutionizing production systems

Horizontal networking:

The use of the Internet of Things (IoT) and Services in value creation systems – across different companies, at the same stage of the value creation chain, from the customer to the supplier.

Vertical integration:

Changing machine architecture from a mechatronic system to a cyber-physical system. Machines or tools then communicate with other CPS in the Internet – vertically within a company, on a technical level from the sensor to the decision-making system on the top floor.

Real-time optimization of complex value creation systems:

This is done by processing big data and using it to make predictions about the future.

gether. Then, the era of virtualization began. Cyber-physical systems were developed and the integration of all value creation processes via broadband communication was realized with the help of cloud computing and the industrial Internet. The last decades witnessed an unprecedented acceleration in the development of new digital technologies: the Internet, WLAN, high-performance computing and finally big data. These technologies have been the key to creating completely new opportunities in networking and data processing, and



Source: Fraunhofer IPA/Rainer Bez

The capabilities offered by IT are truly transforming the digitization evolution into a revolution.

thus facilitating the so-called Fourth Industrial Revolution. Since the 1990s, the degree of networking has grown at a breath-taking rate. Trends such as the Internet of Things (IoT) or

app- and cloud-based services have broken way out of the information and communication sector into the world of production and are adding still more fuel to the networking boom.

Economic Benefits of Industry 4.0

New innovation

- ▶▶ Disruptive business models
- ▶▶ Customer-centered innovation processes
- ▶▶ Open X (innovation, funding, creation, source etc.)

Personalization

- ▶▶ Complexity as competitive factor
- ▶▶ Personalized products and services

Regionalization

- ▶▶ Frugal products
- ▶▶ Local value creation
- ▶▶ Micro factories

Flexibility

- ▶▶ Decentralized work systems (swarm)
- ▶▶ Plug and produce (cyber-physical systems)

Cost optimization

- ▶▶ Variabilization of costs (XaaS)
- ▶▶ Reduction of complexity costs (prosumer, platforms, communities etc.)
- ▶▶ Data-based productivity optimization (big data)

Sustainability

- ▶▶ Savings in energy and material (smart grid, zero waste etc.)
- ▶▶ Resource protection / environmental friendliness (sharing economy)

Staff

- ▶▶ Better working conditions (personalization of work places, reduction of waste, appreciation of competences)
- ▶▶ New working-time models (work-life integration)

Source: Fraunhofer IPA

These achievements would be impossible without the rapid growth in computing power, continuously expanding Internet bandwidth and the greater mobility of the technologies and user devices. The final step of crosslinking-yielded autonomous systems leads to increasing autonomization. This will be achieved through the combination of classic technologies and artificial intelligence which create autonomous, self-organizing systems (e.g. autonomous transport systems, autonomous robots).

The capabilities offered by IT - communication and data storage using Internet technologies as well as the exponential increase in computing capacity - are truly transforming the digitization evolution into a revolution.

Cloud-based platforms

Cloud-based platforms offer applications that run in the cloud, or use services provided from the cloud, or both. There are various kinds of platforms today. IT-oriented production platforms take their origin in IT. Many services and apps exist already. The usual business approach/model is Pay-per-Use for everything. But there are no manufacturing applications. In this environment, big data will be expensive for the user.

Also in business-oriented platforms there are many apps already. The service shops offer internal and external services. Some of the apps could be used in manufacturing and some platforms are available as private clouds. Industry-oriented platforms, however, are at a nascent stage of development.

New imperatives of value definition

The value of a company today does not necessarily depend on

Development Stages of the Digital Transformation

From digital image to autonomous systems

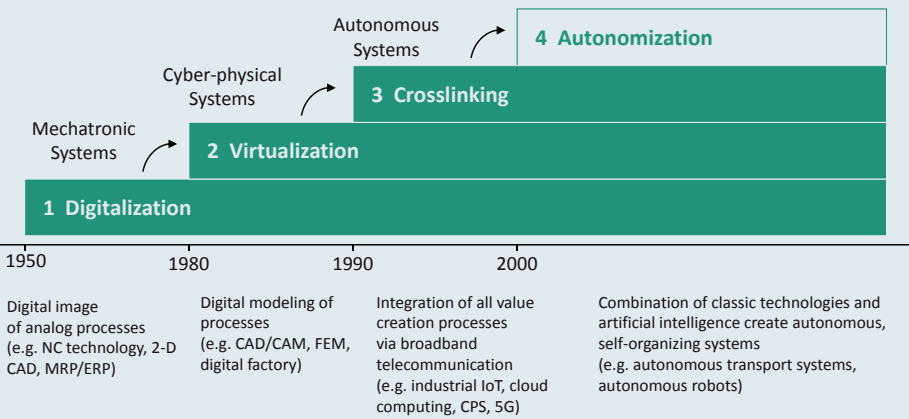

Source: Fraunhofer IPA

Vertical Integration

Core elements of the fourth industrial revolution

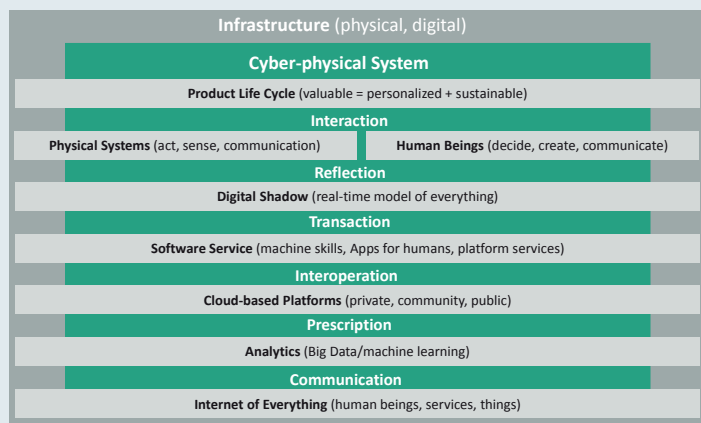

Source: Fraunhofer IPA

resources, namely the number of employees, the machines and plants or the produced and sold number of products. It depends on customer access. The more customers are being integrated via business platforms, the more the value of a company rises. Data is the gold of our business ecosystems.

These examples also show that the characteristics of digital business models are low fix costs (XaaS), because time is money. The marginal costs are close to zero and the revenue develops after generating a lock-in effect by gaining a critical size.

Use and benefits

The advantage of Industry 4.0 is that it offers versatile, highly flexible systems which make it possible to transfer value creation to the location where it can best take place. This reduces complexity costs and generates new potential for improving efficiency. The overall system of objectives for value creation – in terms of time, costs, quality, flexibility and sustainability – remains unchanged but the requirements rise in each individual area. Industry 4.0 extends the scope of solutions used in designing the economic and

In 2020, there will be an estimated 50 billion devices to the Internet, enlarging the IoT rapidly.

sustainability aspects of value creation systems – from the process to the business ecosystem. This perfectly integrates all the value creation partners and the end customers. This capability is new. Networking based on platforms, which permit both horizontal and vertical integration, can, therefore, be used to generate and distribute specific tasks or machine functionalities within this economic ecosystem.

Advantages of Industry 4.0

Four core theses for the value creation model of the future describe the advantages of Industry 4.0:

Optimum distribution of value creation processes in an economic network. This connects all the value creation partners, suppliers and customers in a structure with minimal hierarchies and leads to low complexity costs and, thus, a higher total margin.

Optimum distribution of functionalities (services) in the cyber-physical system architecture. This leads to scale effects and greater adaptability of functions throughout the life cycle of technical systems.

Forecasts and future scenarios based on big data and the digital shadow of reality. This provides the foundation for high productivity and agility in complex value creation systems.

Adaptive, self-teaching human-machine interfaces. These integrate employees into the process and eliminate waste. They also ensure full acceptance in the work system and create the basis for agile, robust value creation systems which are capable of learning.

New technologies and business models thus enable suppliers, service providers and customers to take on new roles

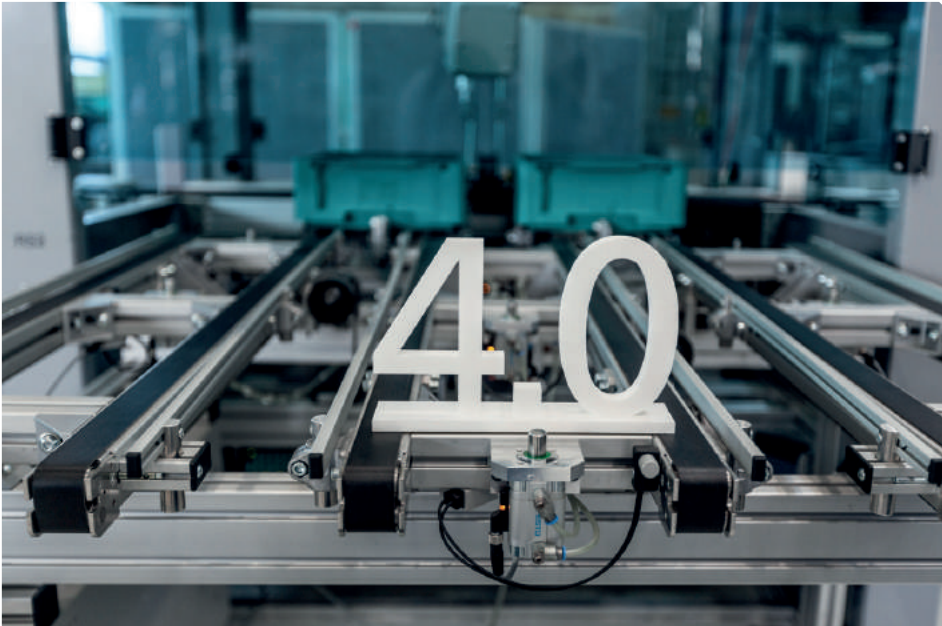

Source: Fraunhofer IPA/Rainer Bez

Industry 4.0 will bring back the expertise of the engineers directly into the value creation process and improve the status of production workplaces.

In the framework of Industry 4.0 and the digitization of value creation within platform-based ecosystems, there is a change of perspective, because of the use of big data.

and collaborate in the value creation process. The product can become an information carrier and, therefore, support every phase of its life cycle autonomously. This is known as digital product memory. It also opens new horizons for designing and optimizing the value creation process. It offers the potential for major savings in almost every area of value creation.

The use of real-time stock data and other information throughout the supply chain can reduce stock costs by up to 40 percent. Production and logistic costs can also be reduced by 10-30 percent by using smart wearables at production workplaces or analytics to boost overall equipment efficiency. Complexity costs are usually indirect costs and offer even greater potential savings. They can be reduced up to 70 percent by integrating the customer of the product into the value creation system in each case, using comprehensive service products and decentralization,

and removing hierarchies from value creation responsibilities. In this “prosumer” model, the customer is not just a consumer but also one of the producers. He performs tasks which used to be the responsibility of the manufacturer. This offers further cost savings.

Companies can download CAD software, design the part they require and then order it at the click of a mouse. Everything as a Service, the XaaS concept, is also leading to the emergence of “complexity bundlers”, which focus on one topic and develop special expertise in that area. They offer services to match, such as procurement platforms that select the best quality and best value suppliers. This cuts the manufacturer’s workload without compromising on the scale effects.

Step-by-step, the digital transformation is breaking down the Taylorist principle of separating labor and knowledge. In future, knowledge will be transferred directly to the production line. Employees will

once again become competent to make decisions in every area – using assistance systems where necessary – and concentrate on high-value tasks such as decision-making and design. Seen from this standpoint, Industry 4.0 will bring back the expertise of the engineers directly into the value creation process and improve the status of production workplaces.

Challenges of dealing with big data

In the framework of Industry 4.0 and the digitization of value creation within platform-based ecosystems, there is a change of perspective, because of the use of big data. Complicated contexts are being systematically analyzed through root cause analysis. The complicated network is divided in small entities and correlations are being examined. There is only random sample analysis and thus a deductive approach. The question behind is “why?”

In contrast, complex contexts are no longer being analyzed with regard to their causes. This way, correlation replaces causality. Regularities are being derived from all available data, because pattern recognition is available, e.g. customers behaviour patterns. The complete data screen is being analyzed in an inductive approach. The question here is “what?”

The Road Ahead

Cyber-physical systems connect the IoT with people and new tools, resources and services in production systems – in real-time. This lies at the heart of the Fourth Industrial Revolution, in whose context value creation is platform-based and integrated in business ecosystems. Today, the market is ready and consumers buy eagerly. 

VISIT

Organizer



Indian Machine Tool
Manufacturers' Association

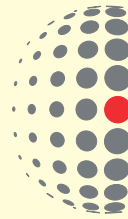

DELHI

MACHINE TOOL EXPO

2017

10 -13, August 2017

HALL 11, 12 & 12A

Pragati Maidan, New Delhi

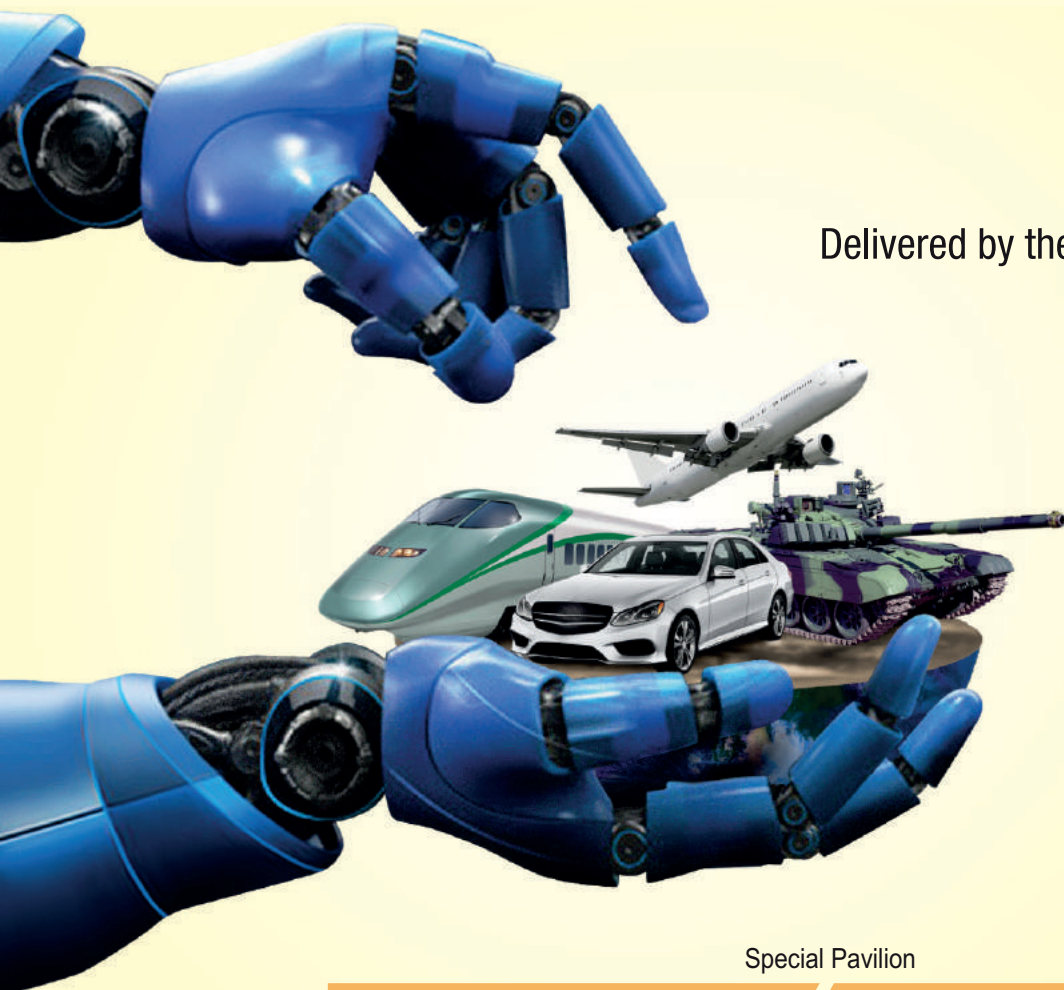

Delivered by the organizer of



Register Online &
Print your own badge

Special Pavilion

WELDEXPO
Exhibition for Welding, Cutting & Joining | 2017

**METROLOGY
EXPO**
Exhibition for Testing Instrument,
Metrology and Equipment | 2017

Empower Manufacturing

Experience Delhi Machine Tool Expo 2017

FEATURED EXHIBITORS

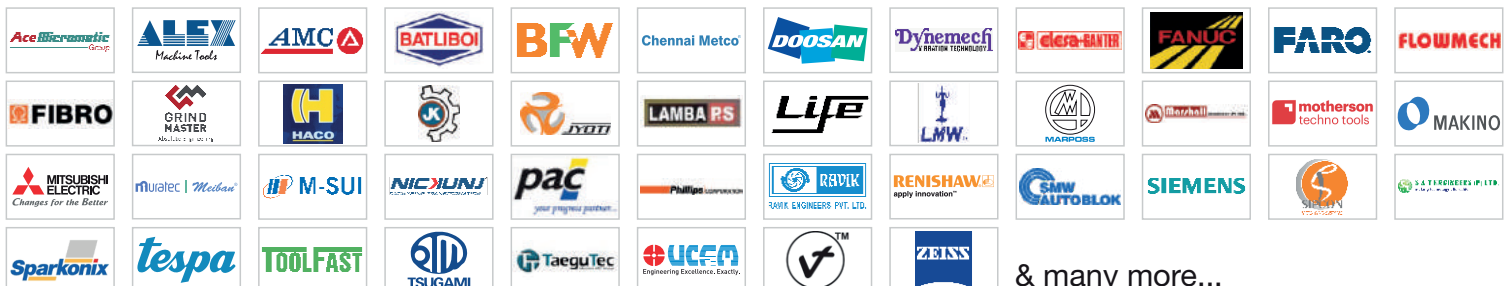

& many more...

www.mtx.co.in



Source: VDW

“India’s industrial sector is very active, and keen to play a role on the international stage.”

Carl Martin Welcker
General Commissioner
EMO Hannover 2017

PRODUCTION TECHNOLOGY @ ITS BEST!

The EMO Press Preview, held a few weeks ago, presented Modern Manufacturing India the opportunity of an exclusive interaction with Carl Martin Welcker, General Commissioner, EMO Hannover 2017. An insightful read on the bandwidth of the latest production technologies in metal-cutting and -forming machine tools to be displayed in the fair.

The theme for EMO Hannover 2017 is “Connecting systems for intelligent production”. Against this backdrop, please elaborate on how Industry 4.0 is contributing towards metal-cutting applications?

CARL MARTIN WELCKER: Industry 4.0 describes the current mega-issue in the indus-

trial sector. With the combination of digitalisation and networking, the protagonists involved are anticipating the next boost to productivity. In the machine tool itself, digitalisation has long since been implemented. The task now is to network the entire production

operation, the complete value-added chain. In a consistently networked manufacturing line, flexible production is possible with optimised work sequences so that even rush order can be accepted in small batch sizes. Complete networking with real-time communication and control

creates the greatest added value when it implements horizontal communication from the order booking to actual dispatch. Inside the value-added chain, moreover, logistical partners and customers need to be networked in addition to the vendors, to achieve maximised productivity, flexibility and efficiency.

How can the software analysts and metal-cutting specialists collaborate to bridge the gap of understanding between metal-cutting applications and big data analytics?

WELCKER: The integration of machines into evolved IT systems faces the challenge of having to operate with highly disparate interfaces. In this context, software specialists play an important role in making trouble-free data interchange possible. Furthermore, large quantities of data have to be managed. This is not the traditional core competence of machine tool manufacturers. Rather, it requires smart data for its analysis. In order to develop fit-for-purpose approaches here, the empirical knowledge of production technicians will be, in its turn, essential. Therefore, interdisciplinary teams will be indispensable in the future.

The global manufacturing sector is waiting for the EMO Hannover to take place as it is the biggest platform for witnessing the latest advancements in production technology. Kindly elaborate on the new additions this year.

WELCKER : Despite digitalisation and networking, the traditional requirements for machine tools and manufacturing systems remain crucially important, since after all, customers wish to produce their parts productively, in high quality, and cost-efficiently. New machinery concepts, reliable components, dependable machine control systems plus intelligent process design and control combine

to meet these requirements. The EMO Hannover will be showcasing affordable standard machines with simple concepts, maintenance-friendly standard components and numerous customisation options. The other side of the spectrum consists of productive multi-purpose and specialised machines for ultra-stringent qualitative requirements in large-series and mass-production applications. They incorporate multifaceted automation solutions, and ensure favorable unit costs, thanks to complete machining and technology integration coupled with maximised reproducibility and availability. Then there's Industry 4.0 as well. We shall see at the EMO Hannover what solutions will be attracting particular attention. Unfortunately, this is very difficult to estimate beforehand.

For the Indian participants - exhibitors as well as visitors - what are the key takeaways from this edition of the mega show, especially when there is a dedicated day for India in EMO?

WELCKER: Indian exhibitors and visitors will once again be able to confirm for themselves that the EMO Hannover is the hotspot for all the sector's players. As the world's premier trade fair for its chosen sector, it is truly international in character. Exhibitors will be coming from 45 different countries and visitors from more than 100. This is being reflected in the global machine tool business. And India is significantly involved, both as a customer, an investor, and a vendor as well.

What is the objective behind organising the India Day at the EMO and what potential do you think India holds in terms of offering its technologies to the global machine tool sector?

WELCKER: In its supporting program, the EMO Hannover repeatedly focuses on attractive



“There will be a display of productive multi-purpose and specialised machines for ultra-stringent qualitative requirements in large-series and mass-production applications in EMO Hannover 2017.”

Carl Martin Welcker

markets. With its good development prognoses, India is an obvious choice. In 2017, the exhibitors in Hannover include 35 Indian firms. This number is considerably higher than last time and shows that more Indian vendors are internationally active. At the last EMO Hannover, moreover, Indians were the third-largest visitor grouping from outside Europe. For September, six entrepreneurial delegations have already announced they will be attending, organised by various trade associations and institutions. For the India Day, we have succeeded in bringing directly on board many experts from India, who will be presenting their appraisal of ongoing developments. Overall, this picture shows that India's industrial sector is very active, and keen to play a role on the international stage. 

The interview was conducted by:
Soumi Mitra, Editor-in-Chief

3D Laser Processing Machine for Long Pipes and Structural Material

3D FABRI GEAR 400 III

Max. material length 8000mm (314.96"), 6100 mm* (240.16"), 12200 mm* (480.31"), 15100 mm* (594.49")

Max. cutting length for unloading 8000mm (314.96"), 6100 mm* (240.16"), 12200 mm* (480.31"), 15100 mm* (594.49")

Max. material diameter Round Pipe \varnothing 406.4 mm (16.00") square pipe \square 300 mm (\square 11.81") H beam 300 mm (11.81")

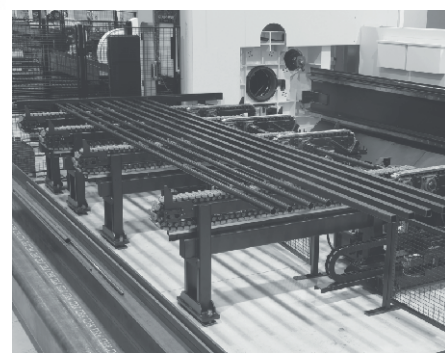

Automatic and Continuous 3D Laser Cutting of Large and Long Structural material

High Precision cutting of complex features by 3D laser head and automatic focus positioning

Optional chain conveyor for increase versatility and maximum quantity of workpieces

Fully Automatic processing of pipe and structural material by a total of 32 axis

High

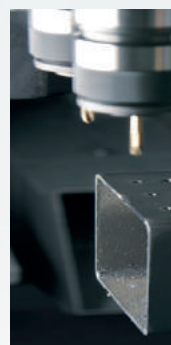

1 Tapping



INDIA TECHNOLOGY CENTER

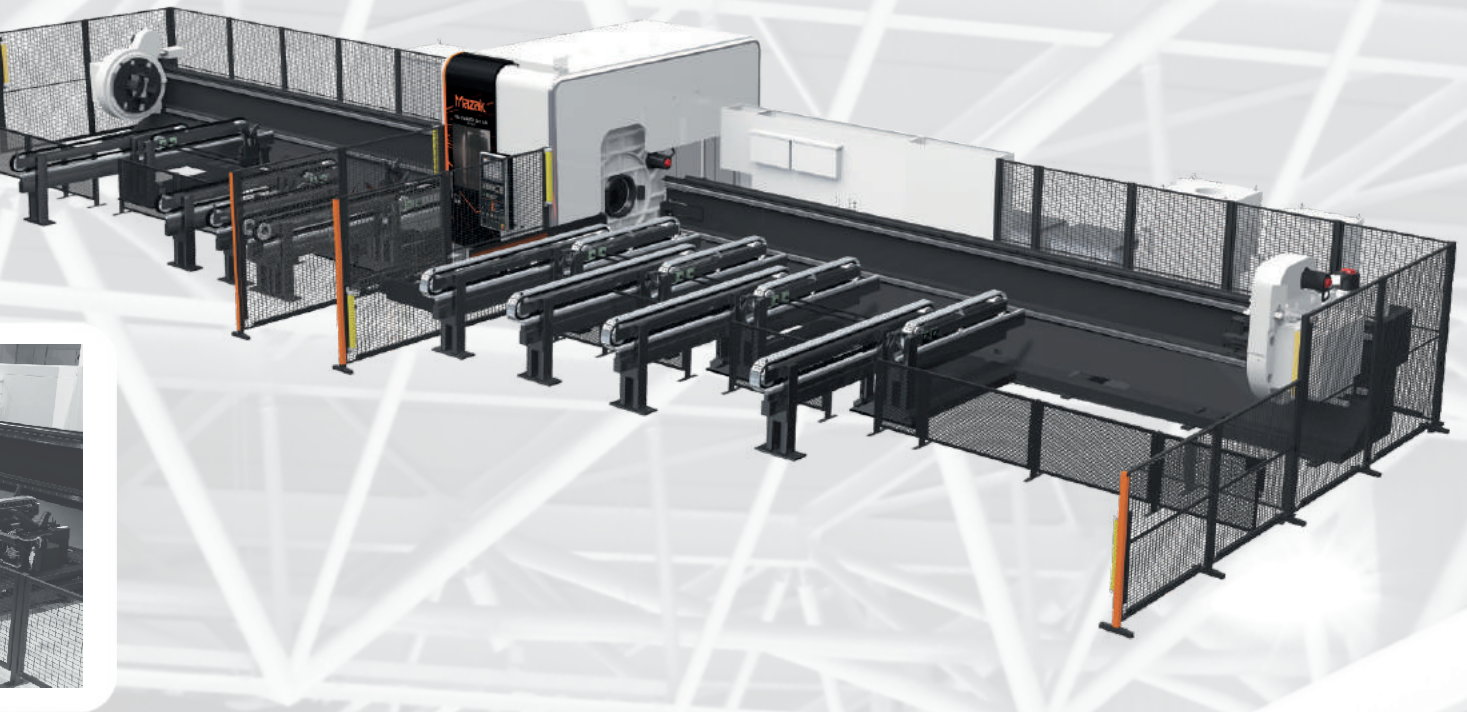

High value and high quality cutting

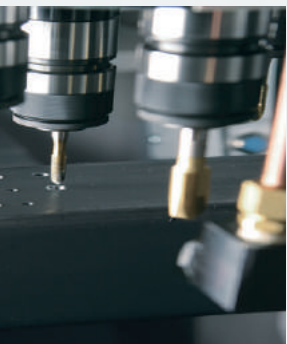

g Unit

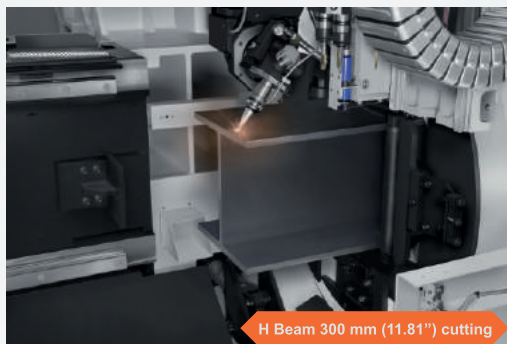

H Beam 300 mm (11.81") cutting

2 Beam Cutting

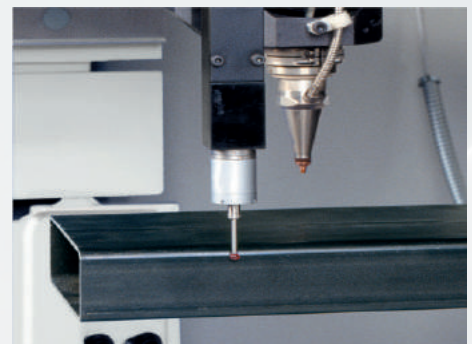

3 Touch Sensor

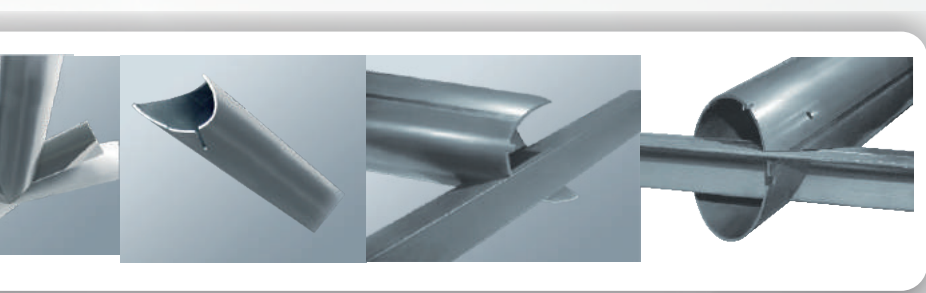

Yamazaki Mazak Pvt. Ltd.

115, Pune Nagar Road, Sanaswadi, Pune. 412208.
TEL: +(91)-2137-668800. FAX: +(91)-2137-668829

www.mazakindia.in

Mazak

Your Partner for Innovation

INDIA-JAPAN: UNTAPPING THE POTENTIAL THROUGH SYNERGY

India and Japan have a history of mutually benefiting industrial collaborations. Recent developments in their engagement paint a brighter picture as the countries are recognising each other's strengths and are leveraging them for their growth. In the machine tool sector, Japan has its expertise and know-how to offer to India, while India can reciprocate with its market size, technological concepts and skilled workforce.

POONAM PEDNEKAR
Chief Copy Editor
Magic Wand Media Inc
poonam.pednekar@
magicwandmedia.org



The exchange between India and Japan that started centuries ago has sustained and kept gaining momentum due to stark complementarities between the two Asian economies. Recent developments in the trade scenario have further strengthened their relation which still has a vast potential for growth.

Stronger bond

Japan is currently India's third largest source of foreign direct investment. Investments from Japan have made a quantum leap during 2016-17, reaching \$4.7 billion from \$2.6 billion during 2015-16. Cumulative Japanese FDI in India is \$25.67 billion between 2000 and 2017, which constitutes 8 percent of India's

overall FDI during this period.

The machine tool sector being the backbone of the manufacturing industry, its prowess determines the success of manufacturing. Hence, Japan being one of the leaders in the machine tool sector, holds immense potential for India in terms of expertise and know-how. India, on the other hand, is important to Japan

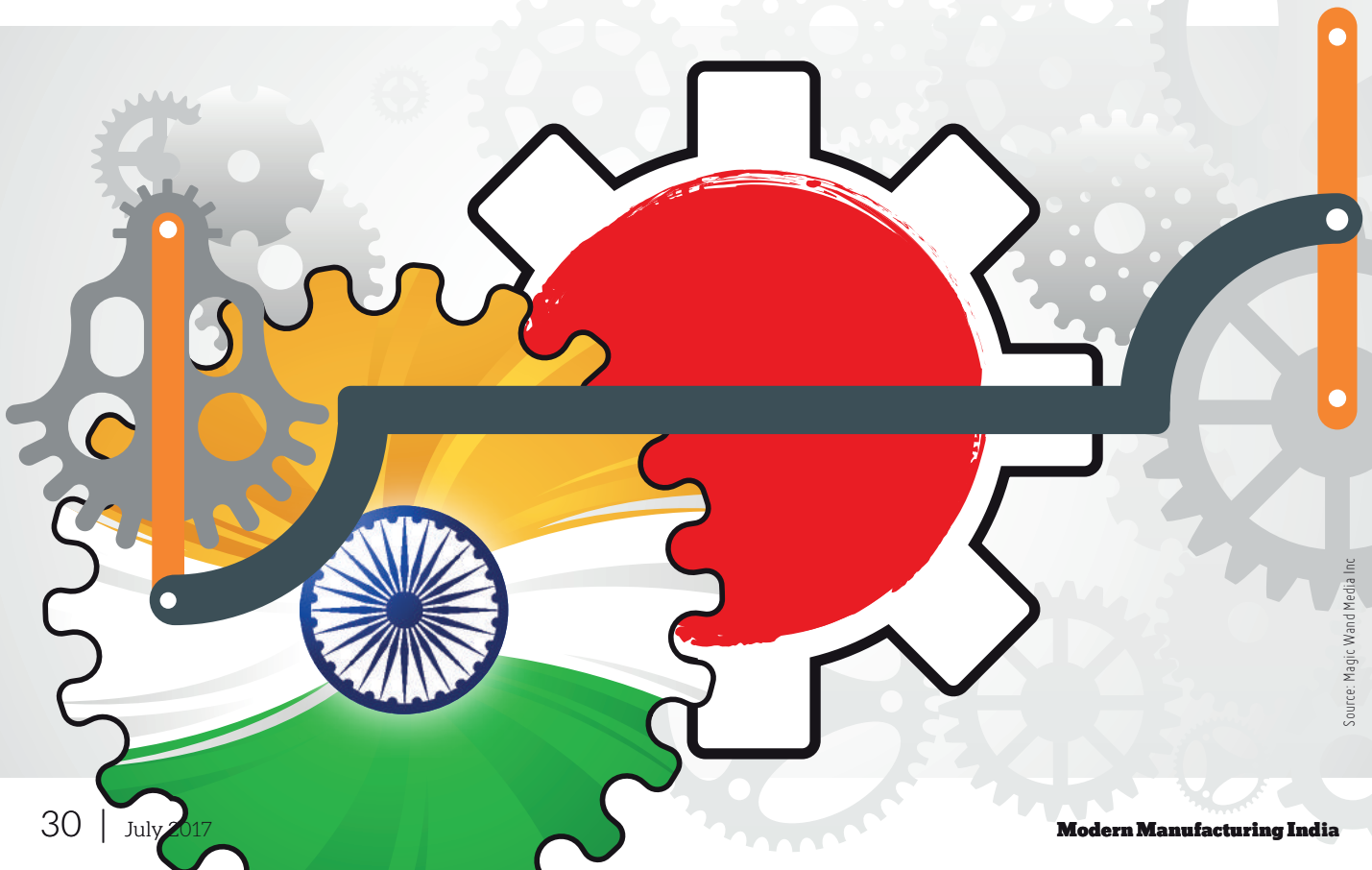



“India has the highest economic growth rate at present, and machine tool demand here is expected to continuously expand in the future. In recent years, the investment of Japanese machine tool manufacturers in India has increased remarkably.”

Yoji Ishimaru
President
Japan Machine Tool Builders' Association (JMTBA)

due to its market size and human resources.

A perfect alliance

The Japan Machine Tool Builders' Association (JMTBA) is an industrial collective dedicated to taking on scientific and technological challenges, and promoting Japanese machine tool industry globally. Yoji Ishimaru, President, JMTBA, said, “In India, advanced manufacturing industries such as automobile, aircraft and electronic devices have been developed. In the future, the demand for mass-production and production efficiency will be strengthened. We assume the need in India for technologies such as robot-based automation, processing that complies with large-scale work or complex shapes, and energy-saving that corresponds to environmental problem will increase. Japanese machine tool industry has advantage in all these fields.”

Trends in Japan

The machine tool industry is in



“Japanese manufacturers and market are open to accept high quality advanced products and technologies. We hope to see more proposals from Indian manufacturers that suit Japanese market.”

Yutaka Nakau
President
Japan Forming Machinery Association (JFMA)

a transformational phase, with new machines and technologies redefining the way production happens worldwide. “Optimizing the manufacturing processes and services by making full use of Internet of Things (IoT) and Artificial Intelligence (AI) is the focus,” shared Ishimaru, describing the machine tool scenario in Japan. Additive Manufacturing (AM), 3D printers, Automation /



“Japanese companies are poised to supply IoT enabled machines to Indian users particularly in automotive sector that will change the demand likely to be posed to Indian suppliers.”

Vivek Nigam
Business Head
Machine Building Division
Isgec Heavy Engineering Ltd

unmanned technology utilizing robots, Precision processing technology such as 5 axis machining centers and turning centers are among other trends. “Japanese machine tool manufacturers are actively working on the development of these new technologies and can provide high performance machines that respond to the development of Indian civil demand,” he added.

Metal Forming & Fabricating Fair Tokyo (MF-Tokyo) is Japan's specialised trade fair that witnesses participation from many countries including India.



Source: JFMA

“Since IT industry has already developed in India, Japanese IoT and AI technologies that connect all the machines and industries will be easily accepted in the manufacturing sector in India, further contributing to improve efficiency. We believe that Japanese additive manufacturing technology will also be required in the development of Indian manufacturing industries in the future,” he emphasised.

Synergy at its best

Indian machine tool makers can learn a lot from their Japanese counterparts. “After the Second World War, the machine tool industry in Japan has greatly developed through the cooperation and collaboration of industry, academia and public sector. Japan has also developed world-leading high-performance machines and offers them to manufacturers worldwide. Japan can, in turn, benefit from adopting technology concepts from India,” Ishimaru conceded. “In India where IT software technology is highly developed, many engineers are working on the development of superb software. There is a vast possibility to incorporate Indian IT technology for Japanese machine tools,” he noted.

Tough competition

Japan, by keeping itself abreast of the global trends, has maintained its lead in machine tools. Out of the top 10 global machine tool vendors, five are from Japan. However, the manufacturers in Japan are receiving tough competition from China in terms of production. Hence, are developing technologically more advanced machine tools to withstand the competition.

MF-Tokyo 2017

Japan takes pride in producing state-of-the-art technologies in metal forming machinery that

puts it in the world's top two countries in development and production. Through industry fairs and exhibitions, the country disseminates its latest technologies of the metal forming industry to the world.

Metal Forming & Fabricating Fair Tokyo (MF-Tokyo) is one such specialised trade fair which attracts high-quality visitors and witnesses participation from many countries including India. Organised by the Japan Forming Machinery Association (JFMA) and the Nikkan Kogyo Shimbun Ltd, the 5th edition of MF-Tokyo was held on July 12-15, 2017 at Tokyo Big Sight, Tokyo.

Latest on the display

With the sub-theme of “Connecting to the Future and Beyond”, MF-Tokyo 2017 brought together metal forming machines, automated equipment, related equipment, processing technologies and service technologies. The fair attracted attendance of influential industrial professionals in the fields of press, sheet metal processing and forming from world over.

“IoT is the key emphasis in order to collect operational status of the machines and feedback with corrective actions, which leads to high productivity and high quality manufacturing,” informed Yutaka Nakau, President, JFMA. “Processing technologies of new materials (composite materials and high metal alloys, etc.) and interfacing machine operational status in production with analysis technologies will play important role in the future,” he elaborated. From India, Isgec Heavy Engineering Ltd participated in the show. Speaking on its relevance, Vivek Nigam, the company's Business Head, Machine Building Division, highlighted, “Our objective was to assess ourselves against the best in the world to

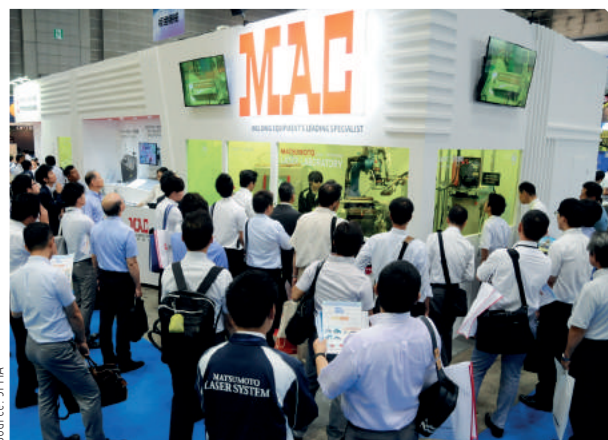

Source: JFMA

Japanese machine tool manufacturers are developing technologically more advanced machine tools to withstand the competition and maintain its lead.

become a global machine building company. MF-Tokyo provides the visibility one needs and the opportunity to get up close with the key decision-makers of Japanese MNCs around the world.” “Today IoT and 4.0 is the thing which most manufacturers globally would follow. India, inherently known for a strong software base, is likely to lead the trend. Next most researched area is tribology involved inside the mechanical arrangements of metal forming machines,” he shared. Further he added, “A new concept of ‘Textured Bushings’ is introduced in which micro dimples are made on Bushings with Laser. It gives better lubrication oil retention, and the limits of bearing pressure capacity can be stretched far beyond the present limits.”

Future exchange

According to Yukata, Japanese market is open to high-quality advanced products and technologies from India. “Machines networked with the software applications based integration could be a major contributor from India. For imports into Japan, there is still room for an appropriate technology that can offer value to the users there,” stated Nigam, having had a recent brush with Japanese market. 

International Machine Tools & Industrial Trade Fair

18th Edition

inter



2019

6 to 10 JUNE 2019
CODISSIA Trade Fair Complex
Coimbatore, INDIA

CONCURRENT EVENTS



ORGANISED BY



CODISSIA
Intec Technology Centre

INTEC 2019

P: +91 422 2222396 / 397
E: intec@codissia.com

www.intec.codissia.com

RAISING THE BAR

Lakshmi Machine Works Ltd (LMW) seems to have mastered the art of staying ahead of the game. One of its strong arms, the Machine Tool Division, has been garnering rave reviews in the industry for its relentless focus on customer satisfaction.

POONAM PEDNEKAR
Chief Copy Editor
Magic Wand Media Inc
poonam.pednekar@
magicwandmedia.org



LMW's impressive
Machine Tool Division
in Coimbatore

To make it big in business, one needs to be gifted with the knack of recognizing gaps in the market and filling it innovatively.

The machine tool division of LMW Ltd owes its birth to one such gap of high-end CNC machines in the country in 1988. The machines were then getting imported from countries such as Japan, Germany, the USA, Italy etc. "Since we had been successful in fulfilling the high-end textile machinery need in the country since 1962, we could recognize the opportunity," recounted

K Soundhar Rajhan, President, Machine Tool Division, LMW Ltd. Today, the enormity of the division can be determined from its built-up area of 32,000 sq mt spread over sprawling eight acres in Coimbatore. "Almost all major Automobile OEMs and Tier-1,

"Our focus will be to address the market needs and ensure that we meet our customers' expectations to their utmost satisfaction."

K Soundhar Rajhan
President-Machine Tool Division
LMW

Tier-2 manufacturers form the bulk of our customers. We also have a large presence in the job shop and general engineering sectors. We are a complete solution provider on a turnkey basis. Presently around 30 percent of the machines sold are either turnkey or tooled up solutions and the trend is moving towards more tooled up," he elaborated.

Going strong

According to him, the machine tool sector has been a highly challenging industry in terms of precision engineering, as



Source: LMW

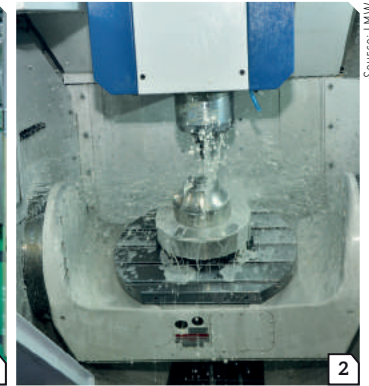

Source: LMW

they are the mother machines which churn out components for every engineering industry. But despite all odds, the company's growth has ever since remained consistently positive, barring a couple of years of global recession. Its tie up with Moriseiki-Japan and Mikron-Switzerland helped the company gain the technological advantage. "Our team has since then grown and gained great experience in the last two decades. Today, we have evolved as an integrated solution provider in metal cutting for the manufacturing industry," he enthused.

Customers across diverse industries

The company caters to a number of industries including Pump & Valves, Oil & Gas, Aerospace, Tool & Die, Defence, General Engineering, and predominantly to the Auto industry, which makes 60 percent of its business. It has recently added an Advanced Technology Center to produce precision components for the Aerospace Industry.

Outpacing competitors

Successful businesses compete on quality. LMW is a firm believer in this proven mantra. "All our initiatives towards enhancing the quality also help improve the efficiency and



effectiveness of the operations in our organization. The benefit is passed on to our customers," he stated.

"Synergy and talent within LMW group is a great advantage for us," beamed Soundhar Rajhan with obvious admiration for his teams.

He gives credit to the company's proactive marketing and business development team that keeps tabs on the market trends and the ever-changing requirements of every industry, and covers the entire array of its customers, ranging from OEMs to job shops.

The efficient R&D team is always on the ball to assess the latest global trends and recognize opportunities. From visiting major international exhibitions, interacting with specialists in the field of machine tools and manufacturing, to interacting with the customers, the team is well-trained to provide innovative

solutions and support operational improvements.

Exports

"Our textile machinery division is one among the top three global players in spinning machinery and has presence in all yarn producing countries," he shared. The Machine Tool Division caters to the domestic market at present and is expanding its reach to Russia, the Middle East and the South Asian countries. "We will achieve about 10 percent of business from exports in the next couple of years," he added.

Further plans

On a concluding note he shared, "We are upgrading by adding new mother machines on need basis and expanding the capacity appropriately. Our focus will be to address the market needs and ensure that we meet our customers' expectations to their utmost satisfaction." 

- 1 LMW Assembly Line
- 2 JU 40 - Simultaneous 5-axis Machining Center
- 3 LMW Vertical Machining Centers
- 4 JU 40 - 5-axis Machining Center

IMPLICATIONS OF GST

India's biggest tax reform has finally arrived. Hailed as a potential game-changer for India Inc, Goods & Services Tax (GST) has evoked a mixed bag of responses from businesses. While some are all praises for the favorable changes in the system, others view differently. An insightful read...

“



AUNCH of GST has brought in a simplified tax regime, which is easy to comply with. Cascading of taxes on account of levy of various taxes have been eliminated with GST coming into effect. Removal of check-posts is helping movement of goods without hindrance. The benefit of GST will reduce the manufacturing costs and hence increase the baseline profit. Reduction in costs will provide headroom for price reduction, benefiting end-users. Post-GST, Indian manufacturing eco-system will become competitive in the global market.”

GIRISH SHANKAR
Secretary
Department of Heavy Industry
Ministry of Heavy Industries & Public Enterprises

“

INDIA is now “One Tax One Nation”. However, there is a need to correct some anomalies in GST rates, whereby some industrial intermediates. For example, CNC system, ball screws, etc., which are critical inputs to building CNC machine tools, attract GST at 28 percent, whereas the end products (CNC machine tools) are at 18 percent. The ideal situation would be to tax raw materials, intermediates and finished products at successively increasing GST rates (say 5 percent, 12 percent and 18 percent). It may take some time for SMEs to move from the earlier tax compliance to GST, but once it is done, it would be a game changer for the Indian machine tool industry.”

V ANBU
Director General & CEO
Indian Machine Tool Manufacturers' Association (IMTMA)

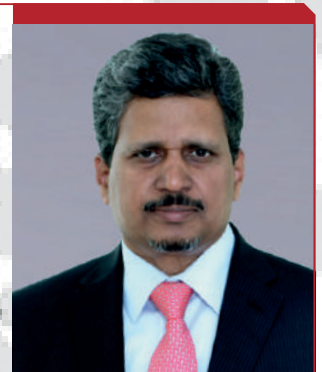



“

GST can be seen to bring transformational change in the indirect tax system of the country. The manufacturing industry, with a significant amount of input originating in different states, will save directly on CST. Since the manufacturing industry has been otherwise claiming ED, CVD/SAD and VAT benefits already, it may not make much difference to the cause of reducing cost. However, transparency in the system will certainly be a boon for all above-board tax paying organizations in the country. Over time, simplification of procedure and transparency will certainly help to improve the size of tax benefits. It is a welcome change that will have a significant impact going forward.”

L KRISHNAN
Managing Director
TaeguTec India Pvt Ltd &
Past President, IMTMA

“

GST aims to replace a plethora of cascading taxes in the states and the Centre and simplify the procedure. It is poised as a catalyst for driving growth in the manufacturing industry. In this transition period, a major concern of the industry is the refund of Input Tax Credit, the realization of which will occur once the final supply is concluded. This may impact the manufacturing segment in a major way due to interruptions in the cash flow and blockage of funds. The domestic industry will need to re-engineer its supply chain strategies in order to cope with the new system. GST, coupled with the Government's ambitious "Make in India" initiative, will definitely boost India's manufacturing sector.”

BHASKAR SARKAR
Executive Director and Secretary
Engineering Export Promotion Council of India (EEPC India)



“

WITHIN the electrical industry, there are mixed feelings about the impact of GST. The reduction in the rate for coal to five percent will slightly bring down the cost of procurement, mainly benefitting thermal projects under operation. How much will it cushion the increase in the operational cost on account of a higher rate for services under GST is yet to be seen. IEEMA is seriously concerned about the higher rate of 28 percent GST announced on some electrical products. It has made a representation to the government for reclassification of GST on these products from 28 to 12 percent. Through our efforts, GST rates of some of these products were brought down to 18 percent, which is a good news for electrical equipment manufacturers.”

SUNIL MISRA
Director General
Indian Electrical & Electronics Manufacturers' Association (IEEMA)





THE manufacturing sector of the developing economies is their major economic driver. However, India's manufacturing industry is still striving to increase its contribution to the country's GDP. The sector will be revived under the focused efforts of the government and by the implementation of a GST regime. One of the advantages of GST is the reduced cost of production that is expected to be spurred by tax reduction. Another is that the non-accessibility of central tax credit over state taxes and vice versa will be removed. Checkpoints at the state border along with the regulatory obstruction reduce the efficiency of Indian manufacturers. The new GST model will unify the Indian market and assist the smooth flow of goods within the country."

RAJESH NATH
Managing Director
VDMA India



THE Auto Component industry whole heartedly welcomes this path-breaking reform. While tier 1s larger companies are GST ready, I am a bit apprehensive about the preparedness of tier 2s and tiers 3s, the small and medium enterprises. Needless to say, any non-compliance on any part of the value chain will defeat this reform. Tier 1s will, therefore, have to ensure that their downstream industry is GST compliant. Being an intermediary industry, we had made a plea to the government that the auto components attract 18 percent GST rates. However, most components have been put at 28 percent. Considering we have a growing aftermarket in the country, a moderate rate would have resulted in better compliance and, thus, enabled tackling the grey and spurious product sales."

VINNIE MEHTA
Director General
Automotive Component Manufacturers Association of India (ACMA)

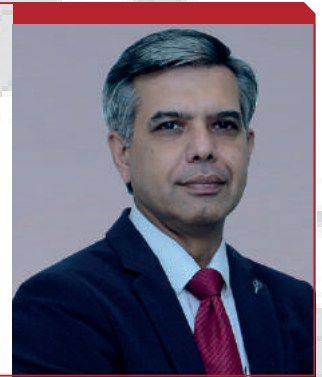

FOR the Manufacturing sector, the net effect is more positive as logistic inefficiencies are greatly reduced. Now GST credit can be taken on all purchases including the admin costs, resulting in the reduction of the cost of operations. The GST law has more clarity with a single rate of GST on a chosen product pan India, though there may be minor anomalies. As the law is implemented and enforced digitally, there will be a greater transparency to it, which will reduce litigation. The businesses too will have to deal with a single authority. Hence, the situation is favorable for further growth in the sector since it will attract more FDI and create more jobs. Finally, the sector's contribution to GDP will also go up."

INDRADEV BABU
Managing Director
UCAM Pvt Ltd



THIS transformational policy initiative will drive economic growth in the manufacturing sector. GST will usher in a number of positives including elimination of the cascading effects of tax. Applicability of taxes only on value additions and availability of more credits will lead to reduced cost of production for the manufacturing companies. As more businesses from unorganized sectors come under GST to compete in the market, there will be an increase in the revenue collections. Hence, businesses which are fully compliant under GST will have better chances to survive and grow. Re-organization of supply chains and distribution networks will result in reduction of costs and business complexities."

BC RAO
Managing Director
Kennametal India Ltd





THE country's biggest tax reform ushers in a new era that impacts everyone, from the common man on the street to business boardrooms. We can see this as another action in the series of actions taken by the government to improve India's competitiveness and the ease of doing business. The biggest beneficiary of GST will be the Manufacturing sector that has an extended value chain which will be relieved of the burden of cascading taxes. This singular tax structure has the potential to enable seamless logistics flow, improve goods availability across the country and allow manufacturers to build new capabilities in efficient distribution systems."

DHARMESH ARORA
Managing Director, FAG Bearings India Ltd &
CEO, Schaeffler India



THE immediate impact of GST can be seen in the Auto sector and the FMCG, where the prices have dropped between five to seven percent soon after the GST rollout. This is not the case in other sectors. Price reduction in these sectors will depend upon how the Anti Profiteering authority functions. Machine tool manufacturers (MTBs) are expected to see a surge in order inflow due to a lower cost of investment, because customers who were not under Excise in the past have moved to GST, wherein GST paid on capital goods is available for set off. Organised machine tool companies concentrated in the South India can save time in transporting machines to customers in the North or far off places due to abolition of check posts across various state borders."

B RAGHAVENDRA
CFO
Ace Designers



THE implementation of GST will significantly improve the competitiveness and performance of India's manufacturing sector. The complexity of multiple indirect taxes had led to significant administrative costs. GST will bring in the ease of doing business in this sector. The manufacturing sector stands to benefit significantly from the introduction of GST. The overall reduction of cascading effect of taxes, especially on the Procedural Cost, Pricing and Profitability, Redress location bias, Post-manufacturing activities and Supply chain should have a positive effect on the cost of manufactured products in the hands of consumers."

ARUN NENE
Manager
Channel Support
Jyoti CNC Automation Ltd



THE impact of GST will definitely be positive due to reasons including reduced cost of production, scrapping of multiple evaluations, ease of registration, improved cash flow, and a unified pricing system across the nation. However, the manufacturing sector has to cope with some immediate and short-term challenges like the availability of resourceful and knowledgeable skilled manpower to implement this system, transaction scheduling as per prescribed deadlines, coordination between the supplier and the buyer, and the revival of special sanctions to specific states/regions/SEZs etc. Last but not the least, GST will surely contribute to the faster realization of "Make in India" initiative by the Hon. Prime Minister of India. It will simplify the tax structure, thus encouraging foreign investors to invest in India."

SACHIN S GAMBHIRE
Senior Manager-Laser Products, Yamazaki Mazak India Pvt Ltd



FOR A GOOD CAUSE

Proton Beam Therapy has several advantages over traditional forms of radiation that destroy healthy human tissues. Learn about the required equipment that will help serve a large number of people desperately in need while it gets manufactured for the first time in India.

While continuing to manufacture sophisticated precision heavy machines and equipment of fine tolerances, Isgec Heavy Engineering Ltd has now committed itself to a cause that can help cancer patients. It has taken up the challenge to manufacture Proton Beam Therapy Equipment for IBA, Belgium. IBA develops, manufactures

and supports medical devices and software solutions for cancer treatments. Considered as the most advanced form of radiation therapy available today, Proton Beam Therapy uses an external beam of radiation to kill tumor cells. It has many associated advantages over traditional forms of radiation such as x-rays that destroy healthy tissues while entering into the body. One of

the IBA's projects is for TATA Memorial Hospital, Mumbai, that will be using it in its treatment of cancer and saving thousands of lives every year.

How Proton Beam Equipment works

Protons after coming out of the cyclotron and an energy selector system arrive in the treatment room via a gantry which revolves 360° around the

Advanced Proton Therapy Equipment manufactured by Isgec

VIVEK NIGAM
Business Head-
Machine Building
Division
Isgec Heavy
Engineering Ltd
nigam@isgec.com



Source: Isgec Heavy Engineering Ltd

According to the International Agency for Research on Cancer (IARC), India had 1.8 million people living with cancer (within five years of diagnosis) in 2012.

patient so that the beam can be delivered at the optimal angle. The highest level of geometrical accuracy of the gantry is required to position the patient at the desired location and precisely treat the cancer cells. It carries the final section of beam line and beam spreading nozzle to direct the beam at tumor cells.

The Proton Beam gantry, a massive steel structure having an assembly weight of 120 ton, is rotated through servo motors. Each gantry is over 5m in diameter and envelopes a space of 10m (L) x 10m (W) x 10m (H). The accuracy requirement for such equipment is highly critical with major emphasis on concentricity of two rings within 20 micron, which is a major challenge for manufacturing industry engineers. It will be the first time such equipment will be manufactured in India.



Source: Isgec Heavy Engineering Ltd

Isgec's other machines

In its endeavor to reduce the range of tolerance and to increase the quality of precision in its products, Isgec's has installed CMM (Coordinate Measuring Machine) of size: 6m x 3m x 2m. It has currently 15 Horizontal Boring Mills (maximum size: 16m x 4.5m x 2.4m (X x Y x Z), 3 Plano Millers (table size: 6000mm x 3000mm, clear height: 3000mm), 6 CNC (maximum turning capacity

diameter: 1100mm, length: 10000mm) and 9 Vertical Boring Machines (maximum capacity diameter: 6.1m, height: 3.1m). Isgec's group in compliance with world-class practices follows ISO 9001:2008 quality management systems and updates to ISO 9001:2015, besides being OSHAS 18001 and ISO 14001 certified.

A glimmer of hope

Though the situation today is far from ideal, the manufacturing industry is doing its bit by inventing machines that can serve humanity. Isgec's and IBA's collaborative effort, which is soon to see light of the day, certainly is a breakthrough that will present tremendous benefits to those suffering. 

Plano Miller
Table Size: 6000mm x 3000mm (240" x 120")
Clear Height: 3000mm (120")

CMM (Coordinate Measuring Machine)
Table Size: 6m x 3m x 2m



Source: Isgec Heavy Engineering Ltd

The accuracy requirement for these equipment is highly critical with major emphasis on concentricity of two rings within 20 micron, which is a major challenge for manufacturing industry engineers.

CAN 3D PRINTING INCREASE MILLING FEED RATES?

With PCD tooling, yes it can. The diamond cutting edges demand a large number of flutes to realize their full effectiveness. While traditional methods for making cutter bodies limit the number of flutes, 3D printing delivers tools with higher flute density and other enhancements as well.

The promise of additive manufacturing will be found in products that are designed for additive manufacturing—that is, products that take full advantage of the geometric freedom that 3D printing can realize. A recent successful example of this relates to milling cutters. Komet's "Revolution" line of milling tools includes tool bodies made through metal additive manufacturing to realize design features including a flute density higher than what is practical to



Source: Modern Machine Shop

On this 10-flute tool, the narrow and deep pockets between flutes could be produced through machining, but the machining cycle would be complex and long. A high helix angle for the flutes compounds the geometric challenge. But additive manufacturing makes this form easy to achieve—the cutter body was grown through selective laser melting.

PETER ZELINSKI
Editor-in-Chief
Modern Machine Shop
pzelinski@
mmsonline.com



1 The possibilities extend beyond milling. This new drilling tool from Komet also leverages 3D printing. Complex features of the tool provide passages through the flutes enabling the chips to be safely transported out of the drilled hole. This tool design leverages additive manufacturing for the geometrically complex components, with machined and 3D printed pieces assembled together to make the final tool.

2 The shank of the tool is still produced conventionally, because machining is far more efficient for a form such as this. The head and shank are combined through laser welding. Welding 3D printed heads to mass-produced shanks will also provide an effective way to deliver special-order tools.

Cutter bodies are grown several at a time in each additive cycle. Different standard or custom tools can be grown together in the same build as they are needed.

achieve on conventionally manufactured tools. When it comes to cutting edges made of PCD (polycrystalline diamond), more flutes on the tool translates directly to faster feed rate. Thus, Komet is actually using additive manufacturing to make subtractive manufacturing more productive.

Additive manufacturing: a more efficient option

Cullen Morrison, Director, Production, Komet, sees making tool bodies through 3D printing as being the way of the future, at least for PCD. This cutting tool material often can take



advantage of all the flutes it can get, he says. It is capable of such high material removal rates in the materials it typically cuts—aluminum and carbon fiber composite—that the number of flutes can be the limiting factor on feed rate and productivity. This is increasingly true as facilities using this tooling adopt modern machine tools with high acceleration rates. However, obtaining a high number of flutes is problematic in cutter bodies made through machining, because the small pockets resulting from high flute density have to be milled out painstakingly using light cuts with small tools. Additive manufacturing offers a more efficient option.

Now, high-flute-density bodies are grown several at a time at Komet's headquarters in Germany on a selective laser melting machine from Renishaw. After these bodies are separated via EDM from the build plate used in the additive process, they are ready for the PCD edges to be brazed on. Komet grows only the heads of the tools this way, laser welding them onto the shanks, because the shanks can be manufactured more economically in conventional processes.



Source: Modern Machine Shop

Benefits abound

Morrison says the advantages of additive manufacturing for the cutter heads go beyond flute density. There is also the flute pitch. Previously, a pitch of 4 to 5° is the best the company could efficiently achieve, because the clearance challenges of reaching a cutting tool past the flute in order to mill out the pocket precluded a steeper angle than this. But in this case as well, the geometry consideration poses no challenge for additive. On the new tools, Komet has produced flute helix angles up to 20°.

The 3D printed tools likely will also realize longer life, he says. The reason is coolant delivery. With additive, coolant channels can be grown inside the tool along snaking paths that exit precisely where the fluid can be most effective. On previous tools, the positioning of coolant channels was always a compromise resulting from the need to drill a straight hole past the clearance obstacles in the way of this drilling.

One other advantage of additive manufacturing might be the most transformative of all, Morrison adds: It will permit faster lead times for special tools. With 3D printing, the range of design options for these special tools increases, and unusual designs specified by special-order customers can move into production practically as soon as they are modeled.

No hindrances

It will take more additive manufacturing capacity to fully realize the promise of the capability for special orders, informs Morrison. The company is exploring how far to advance with this means of production, and how quickly. 

CHIP COMPACTING: MAKING THE BEST OUT OF WASTE

The country's manufacturing sector is constantly on the lookout for ways to minimise waste streams and maximise its cost savings. Chip compacting could be a major step towards industrial waste management for reducing national loss and contributing to sustainability.

Metal swarf before and after compacting.

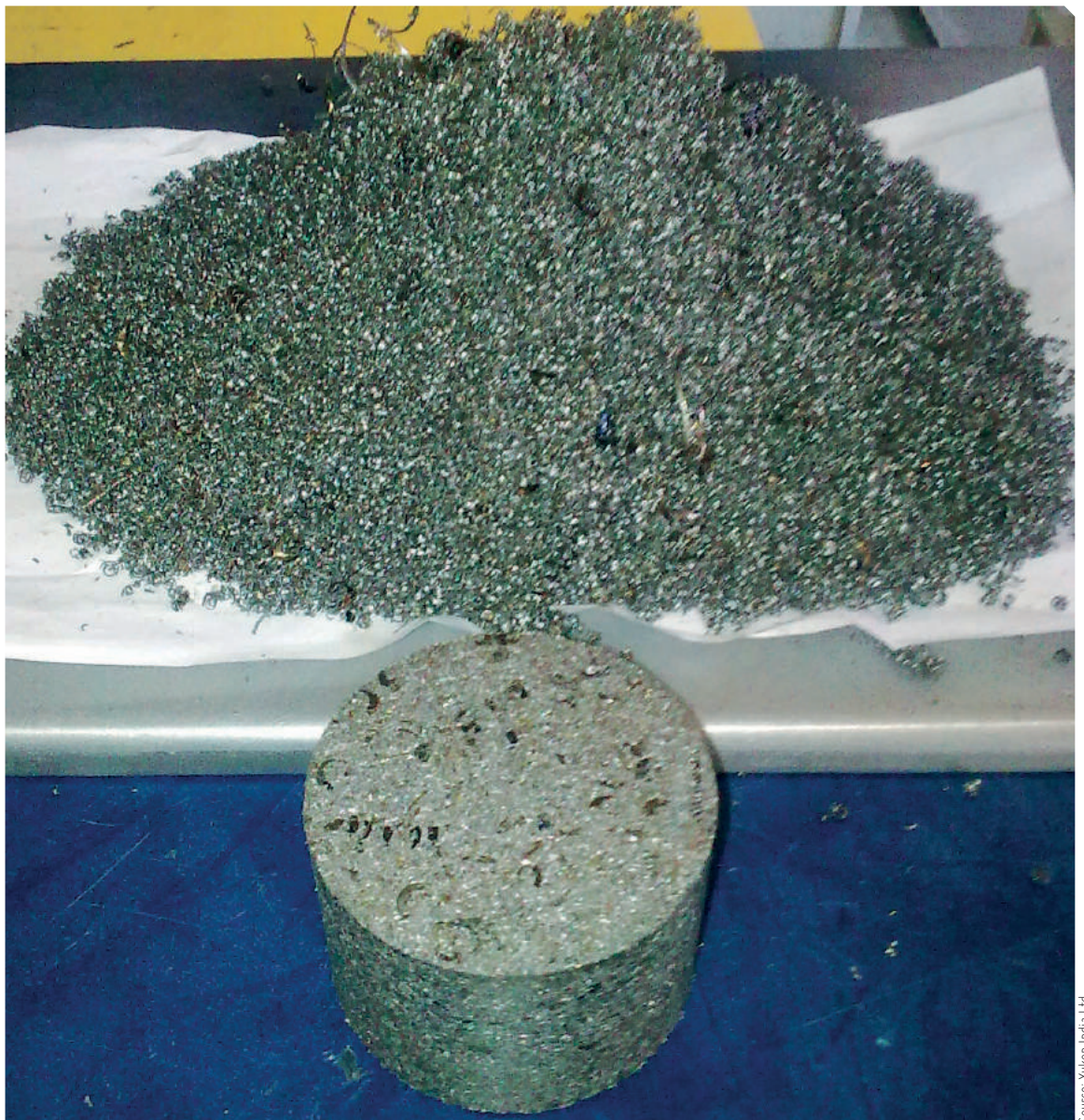

A BHASKARAN
Ex-General Manager -
HMT Machine Tools Ltd
& Yuken India Ltd
alakkil.bhaskaran@
gmail.com



Source: Yuken India Ltd



Source: Yuken India Ltd

80 T Chip Compactor manufactured at Yuken India Ltd.

It is a point to ponder that despite no dearth of commitment, our leaders are still far from providing a large part of our country the basics such as clean drinking water, good roads and uninterrupted electricity. What we fall short of is the resources, which can be saved if all resolve to participate and contribute. Our industry leaders, economists, leaders, bureaucrats and experts often present the excellent solution of 3Rs: Reduce, Reuse and

Recycle. If practised with zeal and commitment, it guarantees saving in terms of money, materials and labor, which, in turn, can be effectively used as the means for fulfilling the above basic needs.

There is a fourth R - Responsibility, which means a measured accountability that should start from top and percolate down.

Wastage in Manufacturing

In the current scene of the



Source: Yuken India Ltd

Briquetted steel and cast iron chips.

Metal Cutting Industries - Tiny, Small, Medium and Large - of our country, a huge wastage is happening unabated. There lies an enormous potential of tapping big benefits out of

BENEFITS OF CHIP COMPACTING

- ▶▶ The coolant which is carried with chips is squeezed out making it available for reuse.
- ▶▶ The volume of chips to briquette is 4 - 40 times depending on the type of chips. This makes transportation safe and cheaper by 75 percent.
- ▶▶ The surface area of briquette in comparison with chips is less than 0.1 percent. This reduces oxidation and slag formation and gives 5 - 20 percent more yield, all for free.
- ▶▶ The briquette is safe for handling and transportation. Hard and sharp pieces of chips that fall on the road are a big danger to the vehicles that use the same road.
- ▶▶ Dry briquettes compared to dripping wet chips do not contribute to ground water pollution.

Rules in place

- ▶▶ With the goal of making green technology a reality, it should be made mandatory to recycle 100 percent metal chips produced in our industries - Tiny, Small, Medium and Large - without any exception. Every drop of coolant needs to be extracted and suitably treated and reused. This is possible if chips are compacted at the source into dry briquettes, transported safely to foundries and melted. If required this should be part of the Factories Act.

Automatic Chip Compactor with conveyor loading.



Source: Yuken India Ltd

the waste if certain issues are controlled.

Machine Tools and Equipment, Automobile, Tractors, Aircraft, Heavy Electricals, Defence Production, Railways, Motors, Engines, Engineering, and Ancillary Industries are

where large scale continuous machining happens. And in the process of machining, metal chips are generated. By a safe estimate, the quantity of chips generated in India is to the tune of 15-20 lakh tons per year. These chips are of cast iron, steel, aluminum, copper, brass, bronze, titanium, and silver etc, and are of different sizes and shapes. This is not treated as metal but just scrap.

Resorting to right measures

The agony is that approximately one fourth of the chips of the cheaper metals such as cast iron and steel are not recycled

at all and allowed to pollute the environment. What is recycled is not done efficiently. Metal chips are injury prone for handling and transport, yield more slag and less metal, and consume more energy and labor. The coolant carried by chips burn in the furnace giving thick fumes, leading to pollution and wastage.

Aluminum chips if compacted into briquettes and melted will yield a neat 15 percent more in comparison to melting loose chips.

The logic is simple:

» Loose chips have several hundred times more surface area exposed to air and heat in comparison to briquetted chips.

» A large amount of coolant which is cutting oil, neat to 5 percent solution in water, which is otherwise carried by the chips, is expelled and saved during compacting into briquettes. Almost 95 percent of smoke and fumes are eliminated by briquetting.

» Briquettes get immersed in the molten metal (chips float) making efficient heat transfer and less energy consumption. The extra yield alone will take care of the cost of compacting.

Loss that can be saved

In a nutshell, there is a huge national loss of 4-5 lakh tons of metals of different types every year just because the generated chips are not recycled the right way. Starting from mining, transporting, smelting and processing, to making it ready for use, approximately ₹4000 crore is the amount of money is spent into making them, which adds to the loss. 



Source: Yuken India Ltd

Witness best practices in manufacturing



National Productivity Summit 2017

“Showcasing Competitiveness in Manufacturing”

4 - 5 August 2017, Hyatt Regency, Pune



To champion the cause of Productivity and enhancing competitiveness in the Indian manufacturing industry, Indian Machine Tool Manufacturers' Association (IMTMA) is organizing the 11th edition of National Productivity Summit on 4-5 August 2017 at Pune. The event showcases best practices in manufacturing through Inspiring Keynotes, Live Case Study Presentations and Plant Visits.



4 Enriching Keynotes



6 Insightful Plant Visits



8 Interesting Case Studies

Live case study presentations on best productivity practices from renowned companies

Contesting companies



Registration for participation must be made online only.
To register online, log on to www.productivity.imtma.in

For details, contact :

Abhishek, tel : 080-66246829 / 9886611007; (abhishek@imtma.in)

Laxmikant, tel : 080-66246665; (laxmikant@imtma.in)

Indian Machine Tool Manufacturers' Association

@ Bangalore International Exhibition Center (BIEC), 10th Mile,

Tumkur Road, Madavara Post, Bangalore - 562 123

www.imtma.in



www.imtma.in

ORGANISED BY

Indian Machine Tool Manufacturers' Association

AWARDS SPONSOR



ENSURING MAXIMUM PRODUCTIVITY

A CNC-based hybrid tool solution, the Ambit multi-task system, from Hybrid Manufacturing Technologies, can be integrated into almost any CNC metalworking machine. With an upgrade to Beckhoff's PC-based control platform with EtherCAT as the fast fieldbus system, the Ambit solution enables the alternate use of metal removal and metal deposition heads in the tool spindle, and ensures optimized machine communication.

The hybrid tool solution from Hybrid Manufacturing Technologies combines conventional CNC technology and additive production processes with the ability to provide both machining and metal deposition tools on the same spindle. The tool

change is performed automatically. Machine tool manufacturers who opt for the Ambit hybrid solution can expand the possibilities of their standard CNC machine by integrating additive manufacturing without additional and tedious re-clamping operations and programming steps. The post-treatment of components, such as polishing, milling and surface

sandblasting, can also be done with the same machine equipment - so that transfer to another production cell for finishing is not required. The use of different material compositions for the same product is also possible, and inspection during production guarantees quality grades that cannot otherwise be achieved or determined.

The hybrid system is controlled via a Beckhoff CP2218 multi-touch Panel PC.

Source: Beckhoff Automation Pvt Ltd



Source: Hybrid Manufacturing Technologies

Fully-automatic tool change for CNC machining and 3D printing

"The Ambit hybrid kit was developed to offer compatibility with most CNC machine configurations and robot platforms," explains Dr Jason Jones, Managing Director and Founder, Hybrid Manufacturing Technologies. "Equipping an existing multi-axis CNC machine with automatically exchangeable deposition heads makes 3D printing in metal possible without having to purchase a separate machine. This not only reduces costs, but also enables extensive options in the operation of CNC machines." The hybrid system supports a wide range of processing heads with different geometries, laser profiles, powder supply configurations and unfocused beams in order to enable a variety of processing steps. These include 3D metal application, welding, marking, chipping, drilling, pre-heating, annealing/relief, surface remelting and cleaning, and much more. The standard equipment can accommodate up to 15 processing heads. However, an unlimited number of heads can be added, depending on the space in the tool changer and the control system performance.

Beckhoff control technology selected as the new standard

The Ambit control platform consists of a CP2218 Panel PC with 18.5-inch multi-touch display that runs TwinCAT 3 automation software, as well as an EK1100 EtherCAT Coupler with in-line connected EtherCAT I/O Terminals. "Hybrid Manufacturing Technologies was particularly impressed by the HMI solution from Beckhoff and the possibility to use EtherCAT

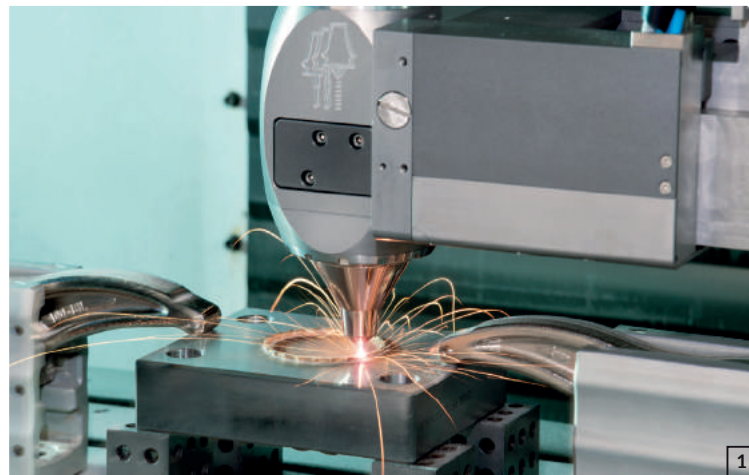

1

Source: Hybrid Manufacturing Technologies



2

Source: Hybrid Manufacturing Technologies

technology in the processing head," stresses Dr Jones.

Peter Coates, Co-founder, Hybrid Manufacturing Technologies, adds: "We can supply our customers with processing heads tailored precisely to unique application requirements that are usable on just about any machine tool. The use of EtherCAT as the communication system makes connection to other production cells simple. TwinCAT 3 also simplifies the connection to other company systems, even extending into the integration of customer-owned Ethernet-based control and ERP solutions. In the future, we will continue using Beckhoff control technology as the standard in

the advanced hybrid solutions we supply to the global market."

Efficient engineering with TwinCAT 3

"It was a significant upgrade from our previous solution, and after a minimum amount of training, we were able to integrate all our engineering processes into TwinCAT 3. The advantage of programming with structured text is that we do not have to change the platform; instead, we can simply add new PLC code. This means that all controllers run programs made with the same code, which is incredibly helpful," comments Coates on the transition to the PC-based control solution. 

1 The hybrid tool solution developed by Hybrid Manufacturing Technologies facilitates the alternate use of chipping and metal application heads in the tool spindle.

2 The hybrid system supports a wide range of processing heads with different geometries, laser profiles, powder supply configurations and unfocused beams.

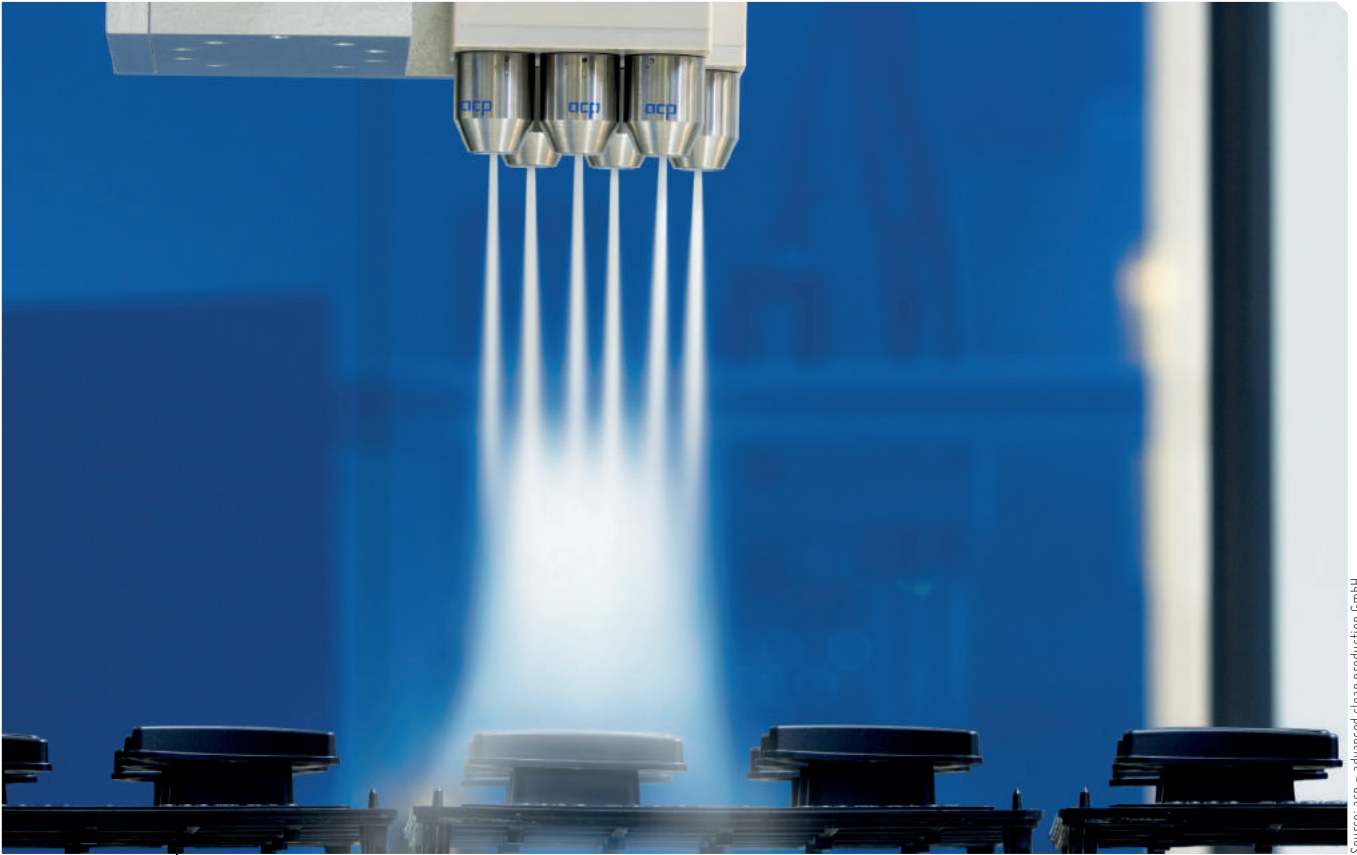

Source: accp - advanced clean production GmbH

Integrated into a flatbed coating line, all process parameters, such as flow rates for compressed air and carbon dioxide, cleaning time, angle of the cleaning jets and motion sequence, are tailored to the geometry of the part to be coated.

SNOW-JET TECHNOLOGY: FOR IDEAL COATING RESULTS

Due to higher quality standards, increasingly complex component designs, as well as modified coating materials and layer structures, cleaning plastic automotive parts in flatbed coating lines is becoming a major issue. OEMs too are increasingly demanding automated cleaning processes. Suitable for Industrie 4.0 applications, the quattroClean snow-jet technology meets these demands with ease.

Regardless of whether it is classical spray painting with water-based or solvent-based paints, fast-drying UV paints, PVD coatings or laser paints for day/night designs – today there are more ways than ever of adding decorative, functional and individual features to plastic interior parts destined for the automotive industry. However,

quality standards for coatings have also never been so high. For this reason, cleaning parts before they are coated is becoming an ever-more crucial process for conventional flatbed coating lines. This is because the cleanliness of the surface to be coated decisively affects coating results. It is, therefore, no wonder that an increasing number of vehicle manufacturers expect

the specifications for such components to include an automated cleaning process..

Space-saving, dry cleaning system

A conventional power wash system that uses an aqueous cleaning medium and a downstream water dryer has its limits. On the one hand, the process is expensive, energy-

DORIS SCHULZ
Journalist (DJV)
SCHULZ.PRESSE.TEXT.
ds@presstextschulz.de



consuming and takes up a lot of space, making it expensive as far as costs are concerned. On the other hand, liquid residues are sometimes still present when parts reach the coating line, which impairs coating results. Consequently, some coating line manufacturers see the environmentally-neutral CO₂ snow-jet cleaning system quattroClean from acp GmbH as an alternative. The system uses a dry, residue-free process to clean the areas of parts requiring coating in-line. Its compact design, as well as the flexible supply options for carbon dioxide and compressed air, makes it easy to integrate the cleaning module into new or existing coating lines. Depending on the requirements of the coating process, the coating line manufacturer or operator decides whether the system should be mounted onto an existing axis or integrated into a robot.

Reliable with uniform cleaning results

Since it is generated as a by-product from chemical processes as well as from the production of energy from biomass, the liquid carbon dioxide used in the cleaning process is environmentally neutral. Non-combustible, non-corrosive and non-toxic, the carbon dioxide is fed through the non-wearing two-component ring nozzle of the acp system and expands on exiting to form fine CO₂ crystals. These are then bundled by a circular jacketed jet of compressed air and accelerated to supersonic speed. The impact of the non-abrasive jet of snow and compressed air on the surface to be cleaned at a temperature of minus 78.5°C triggers a combination of thermal, mechanical, sublimation and solvent effects. These four cleaning mechanisms enable the

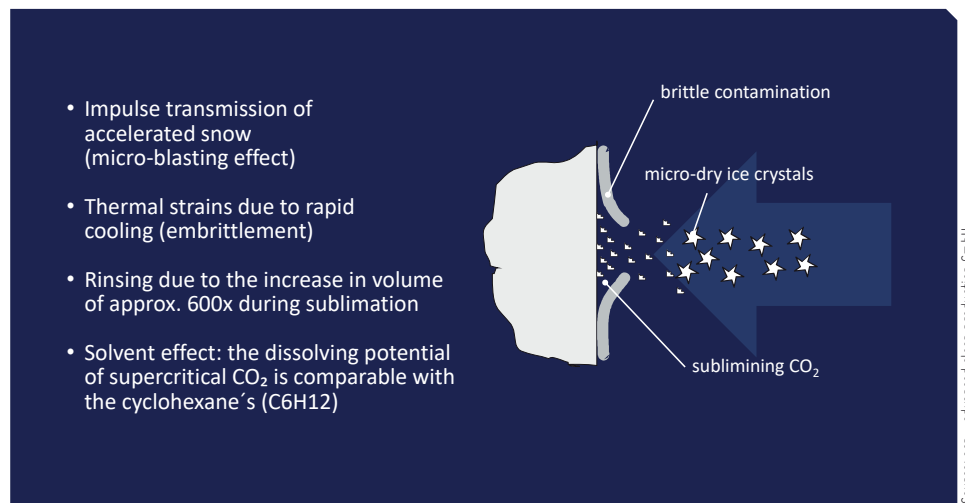

Source: acp - advanced clean production GmbH

quattroClean system to reliably remove filmic contamination, for example residues of separating agents, silicones and fingerprints, as well as particulate airborne contamination, such as dust and fluff. When integrated into a flatbed coating line, one or more nozzle arrays are used depending on requirements. The jet is applied evenly to the complete area to ensure a uniformly clean surface. And in a quality that gives first class results, even when it comes to sophisticated coatings such as piano lacquers. Thanks to the aerodynamic force of the jet, the detached contamination is carried away and removed by an integrated extraction unit to prevent recontamination. Since CO₂ sublimates instantly at atmospheric pressure, components are dry at the end of the cleaning process and are ready for ionizing or coating straightaway.

Customized application

The modular design of the quattroClean system means that it can be tailored perfectly to requirements. All process parameters, such as flow rates for compressed air and carbon dioxide, the angle of the jet and motion sequences - including

For applications in flatbed coating lines, one or more nozzle arrays are used depending on requirements. The consistent power of the jet over the entire cleaning surface guarantees uniform results.

three dimensional movements - can be specifically adjusted to the part requiring coating and filed as a cleaning program in the controller. The effective range of the nozzle array is also automatically scalable to workpiece geometries. With this degree of flexibility, whole surfaces - or just specific areas - even of delicate parts are cleaned effectively, while simultaneously minimizing the consumption of compressed air and carbon dioxide.

The cleaning system is also suitable for Industrie 4.0 applications; via interfaces such as Profibus, it can be linked with the control unit of the coating line or production planning system. This enables the production facility to function fully automatically without any need for manual intervention. Thanks to its reliable cleaning process tailored to the geometry of components, as well as the ability to integrate it into an existing flatbed coating line, the quattroClean system from acp goes a long way towards meeting today's high coating standards. At the same time, it offers great potential to make coating and painting processes more cost-effective and gentler on resources. 

MAKING LIFE-CHANGING DEVICES

Modern medical machine shops are constantly striving to meet the demands of acute precision and complexity. An account of how a tool and die shop came up with innovative solutions in the face of challenges.

Complexus Medical, located in Mishawaka, Indiana, has evolved from a small tool and die shop to a supplier of complex components and assemblies to the medical market. The bulk of its business is dedicated to producing complex orthopaedic instruments, although it

also provides metallic and non-metallic implantable components for knee replacement and related medical procedures. Since medical device OEMs are looking for suppliers that offer competitive cost advantages for the parts and assemblies, price pressure becomes a challenge. However, that is just one of the

challenges that shops serving the medical industry, face today. And those challenges impact not only the equipment that this company has purchased over the years, but also the shop floor practices and business strategies it has adopted to become more competitive. Given below are a handful of challenges that the company faced as well as the actions the shop has taken to address them.

Challenge: Increasing part complexity; tighter part tolerances.

Solution: Increased adoption of multi-axis, multifunction equipment.

Complexus has a number of conventional CNC machines, including VMCs, turning centers, and wire and sinker EDM units. That said, it seems that the shop's multifunction turn-mills and Swiss-type lathes are essential these days to efficiently produce some of the complex, contoured medical work that runs through the shop.

For instance, Complexus has three turn-mills from DMG MORI that operate virtually 24/7: two 12,000-rpm NT1000 models and one 20,000-rpm NXT1000. Each of these offers

Complexus Medical relies on multifunction equipment such as B-axis turn-mills to produce complex medical device components in one setup rather than running parts across multiple machines.

DEREK KORN
Executive Editor
Modern Machine Shop
dkorn@
mmonline.com

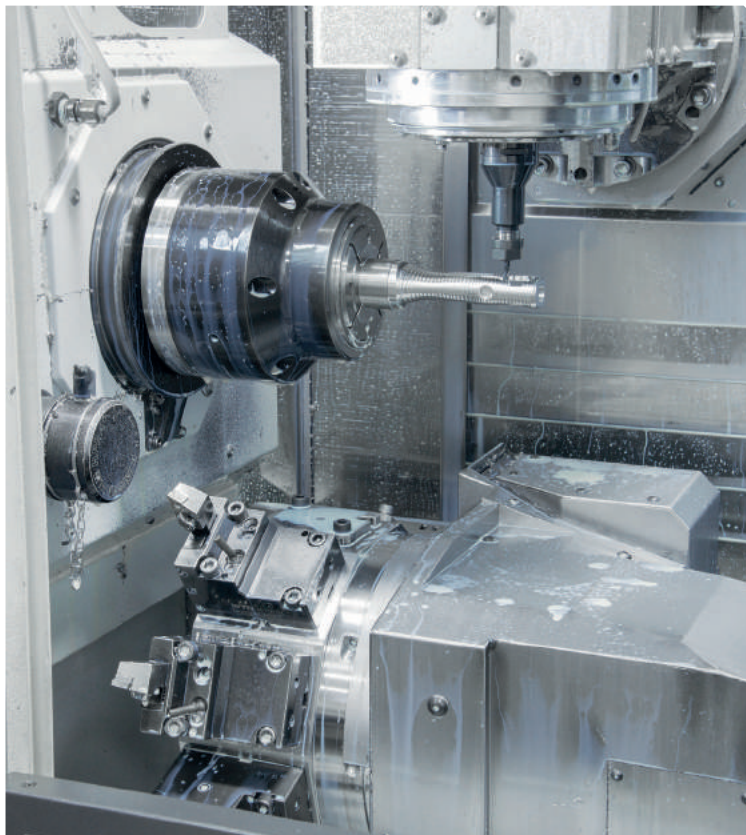

Source: Complexus Medical

a B-axis milling head, a lower turret with live tooling and a subspindle.

One example of an ideal part to be produced on these machines, a component for a medical device for a femoral procedure, is indicated in image 2. Previously, the shop ran the part across seven machines (saw, lathe, another lathe, gun drill, mill, lathe and another mill). Today, it can be completed in one setup on one of these turn-mills. The parts are produced in batches of 100 to satisfy monthly customer demands. The previous method required 25 hours of total setup time (per 100-piece lot) and about 200 minutes of machining time per part. This has been reduced to four hours of total setup time per batch and 90 minutes of cycle time per part using the turn-mills.

The shop also performs gundrilling on these machines, minimizing bore runout by using relatively slow 250-rpm spindle counter rotation that opposes the gundrill's rotation. The part shown above has a critical central bore produced via gundrilling on one of these machines. In this case, the turn-mill's subspindle pulls the part out of the main spindle in three stages, and the part's bore



Source: Complexus Medical

is gundrilled to 0.0002-inch runout.

The company also has four Star CNC Swiss-type lathes. Although these bar-fed, sliding-headstock machines are effective for producing long parts with relatively small diameters (thanks to their guide-bushing design that offers support very near the cut), the shop also uses these machines to produce relatively short parts that require multiple turning,

milling and drilling operations. Machining these parts complete in one setup helps ensure feature-to-feature accuracy while minimizing setup time, work-in-process (WIP) and the number of times a part must be touched.

In fact, complete machining using equipment like this has also impacted the shop's toolroom. Michael says this area isn't nearly as large as it once

Although Swiss-type lathes are known to be effective at machining long, thin parts, Complexus also uses its sliding-headstock machines to produce short parts complete in one setup.

Complexus delivers devices completely machined, laser-welded, laser-marked and assembled to its customers, keeping some secondary processes in-house while outsourcing others to trusted local vendors.



Source: Complexus Medical



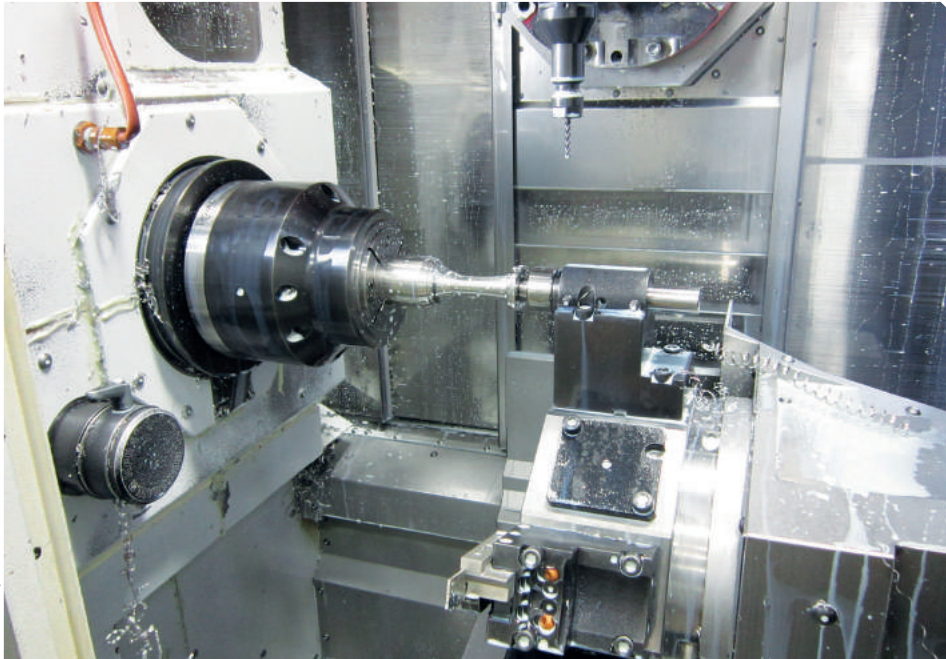

Source: Complexus Medical

For some parts, the shop performs gundrilling on its turn-mill machines. By using 250-rpm spindle counter rotation that opposes the gundrill's rotation, bore runout of 0.0002-inch can be achieved.

was, because the shop doesn't need as much custom fixturing as it previously did when it ran parts across multiple machines. For the medical-grade plastics implant work, Complexus has established a high-speed, non-metallic cell consisting of two four-axis FANUC Robodrills. These 24,000-rpm machines run sans coolant to produce families of knee-replacement parts from ultra-high-molecular-weight (UHMW) polyethylene and other medical-grade plastics. They have fast-indexing rotary tables with four-sided fixtures to enable multiple parts to be installed for longer stretches of unattended machining.

Challenge: More than machining is needed.
Solution: Secondary processes in-house; use of trusted vendors.

The company is selective as to what non-conventional processes to have in-house. The two processes it recently added are laser welding and laser marking. Although the shop had

outsourced these laser processes, extended delivery times spurred it to add these capabilities, especially because they are among the last operations to be performed on medical components prior to customer delivery. The shop can perform these operations in a matter of hours, rather than waiting a day or more for an outside vendor to complete them. This also enables components to be sent to the shop's assembly department for quicker turnaround of completed devices to its customers. However, it continues to outsource processes like anodizing, passivation, heat treating and electropolishing to trusted vendors, rather than dealing with nitric acid and other chemicals commonly used in those processes. The shop can send parts out for heat treating in the afternoon and have them back the following morning. By not bringing all these secondary processes in-house, the shop can concentrate more on its core capability of precisely machining complex components.

Challenge: Design for manufacturability advice sought by customers.
Solution: Increased engineering capacity.

Complexus strives to work closely with its customers' design engineers to develop an effective strategy for component and assembly manufacturing, proactively eliminating potential machining problems at that early stage. By taking this critical early step, the company has the capability of helping refine new-product designs so that complex components can be produced at a more competitive cost. In fact, the shop has become deft at identifying obscure machining problems early on in the process through its design for manufacturability (DFM) capability.

In some cases, customers consult Complexus fairly early in the new product design stage. In other cases, customers approach the shop with a 3DCAD model or a prototype (often produced via additive manufacturing), asking for design-improvement advice that will simplify production.

Clean Operation

The facility is clean, organized and well-lit. Recently it increased its floor space to 40,000 sq ft. As part of the expansion, it added more windows to allow more natural light to shine through and upgraded its lighting system. The previous lighting system provided 40 ft candles of light intensity, but the new system provides 175 ft candles. Improved lighting enables employees to more easily see burrs or recognize signs of machining chatter on parts. This type of manufacturing environment is also attractive to the shop's medical customers because cleanliness and organization is the nature of their business, too. 

It isn't just about building
your goal posts, it's about
winning!



BOOK
your
advertisement
NOW!

September
special issue



EMO
Hannover

Contact:

M: +91 9740048390
+91 9870401498



Indian Machine Tool
Manufacturers' Association

www.mmindia.co.in



Scan to view
eMagazine



EVENT CALENDAR		
EVENT NAME	CONTACT	DATE & VENUE
MACHINE TOOL EXPO 2017	T: +91 (80) 6624 6600 E: info@imtma.in www.mtx.co.in	August 10–13, 2017 Pragati Maidan, New Delhi, India
EMO HANNOVER 2017	T: +91 (22) 6687 550 001 E: info@hmf-in www.emo-hannover.de	September 18–23, 2017 Hannover, Germany
MANUFACTURING SOLUTIONS EXPO 2017	T: +65 (68) 263 000 E: jolintan@sph.com.sg www.ms-expo.com	October 25–27, 2017 Singapore EXPO, Singapore
BLECHEXPO 2017	T: +49 (0) 7025 9206-0 E: info@schall-messen.de www.blechexpo-messe.de/en	November 07–10, 2017 Stuttgart, Germany
AUTOMOTIVE ENGINEERING SHOW CHENNAI	T: +91 (22) 6144 5900 E: info@india.messefrankfurt.com www.aes-show.com	November 09–11, 2017 Chennai Trade Centre, India
MACHINE TOOL INDONESIA 2017	T: +62 (21) 252 5320 E: maysia@pamerindo.com www.machinetoolindonesia.com	December 06–09, 2017 The Jakarta International Expo, Kemayoran, Jakarta, Indonesia
IMTEX FORMING 2018	T: +91 (80) 6624 6600 E: imtma@imtma.in www.imtex.in	January 25–30, 2018 Bangalore International Exhibition Centre (BIEC), Bangalore, India
DIE & MOULD INDIA INTERNATIONAL EXHIBITION	T: +91 (22) 2852 6876/2850 8976 E: tagma.diemould@tagmaindia.org www.diemouldindia.org	April 11–14, 2018 Bombay Exhibition Centre, Goregaon, Mumbai, India
ACMEE 2018	T: +91 (44) 2625 0489 E: info@acmee.in www.acmee.in	June 21–25, 2018 Chennai Trade Centre, Chennai, India
JIMTOF 2018	T: +81 (03) 5530 1333 E: jimtof@tokyo-bigsight.co.jp www.jimtof.org/en	November 01–06, 2018 Tokyo International Exhibition Centre, Japan

To suggest an event, please send details to soumi.mitra@magicwandmedia.in



Source: Magic Wand Media Inc

INTEC 2017: A WINDOW OF OPPORTUNITIES

The 17th edition of the international machine tools and industrial trade fair, INTEC held in Coimbatore in June turned out to be a huge success. The five-day event organized by CODISSIA surpassed its own expectations with the number of footfalls and business turnover.

INTEC, a premier event for industries to exhibit their finest innovations and services, made its appearance yet again on a sprawling CODISSIA (The Coimbatore District Small Industries Association) Trade Fair Complex in Coimbatore from June 01-05, 2017. With the key emphasis on automation and digitization

of the industry, the show hosted over 535 exhibitors and attracted an exact figure of 52,843 visitors in its floor space of 22,000 sq mt. It was instrumental in business transactions worth ₹600 crore during the fair itself, which is quite a leap from its earlier edition that garnered a turnover of ₹125 crore and generated

enquiries to the tune of over ₹375 crore.

INTEC provides an opportunity

CODISSIA organizes the fair in Coimbatore to provide local MSMEs and SMEs an exposure to technological developments happening world over so they can incorporate the same in

Stalwarts from the manufacturing community along with the Union and State Ministers during inauguration of INTEC 2017.

POONAM PEDNEKAR
Chief Copy Editor
Magic Wand Media Inc
poonam.pednekar@
magicwandmedia.org





“INTEC 2017 has contributed to the manufacturing sector by supporting the industries with the latest technologies to move on towards Industry 4.0.”

J Balu
Chairman
INTEC 2017

their manufacturing units. “By bringing in the latest technological solutions for the manufacturing sector, INTEC encourages the local industries to produce components of very high quality, thus enabling the larger industries to pitch in for ‘Make in India’ initiative confidently and ensuring success,” emphasized J Balu, Chairman, INTEC 2017.

The show begins...

The significance of the event was apparent by the presence of many high-level dignitaries from the state and union governments at the venue. Hon’ble Minister of State for MSME, Govt of India, Haribhai Parthibhai Chaudhary was the chief guest.

Representing the Tamil Nadu State Legislature were Hon’ble Minister for Municipal Administration, SP Velumani; Hon’ble Minister for Industries, MC Sampath; Hon’ble Minister for Housing and Urban Development, Udumalai



“INTEC aims to be an ideal platform for first generation entrepreneurs; paving way for start-ups. It will help industrialists by upgrading their knowledge and providing automation solutions.”

R Ramachandran
Vice Chairman
INTEC 2017

K Radhakrishnan; Hon’ble Minister for Rural Industries, P Benjamin; and Hon’ble Deputy Speaker Pollachi V Jayaraman. KK Jalan, Secretary to the Govt of India, Ministry of MSME, New Delhi and Mangat Ram Sharma, Principal Secretary to the Govt of Tamil Nadu, MSME Department graced the opening

ceremony as Guests of Honour. Chaudhary asked the state authorities and CODISSIA’s members to help the local MSMEs in all possible ways to raise their standards to match with their global counterparts. “In the next three years, India will be self-sufficient in the areas of Defence, Railways and Housing. Thus, MSMEs from Tamil Nadu have a wide scope to flourish,” said the Union Minister.

Knowledge sharing

Due to the vast transformation in the business ecosystem, MSMEs are facing various challenges. To seek solutions to the same, the front runners and decision makers of the Coimbatore-based small manufacturing companies gathered at the Global Manufacturing Cluster Vision 2030 (GMCV 2030). The conference was organized by CODISSIA in association with Texas Ventures, a global research and consulting firm.

Opinion matters!

This year’s edition of INTEC aimed at drawing serious visitors and was successful in doing so. To encourage this

INTEC 2017 attracted business visitors from all over the country.



Source: CODISSIA



Jyoti CNC Automation Ltd's booth at the event.

Source: CODISSIA

move, the companies had to pre-register their employees and decision makers for the fair. The exhibitors appreciated the organizers who could bring in the niche crowd that meant pure business.

S Thirumoorthi, Associate VP, BCS Marketing, CRI Pumps, said, "This is the third time we are exhibiting at INTEC and are happy with the visitors and the business leads that we have so far generated. The way the event is organized and handled, it is quite satisfactory."

"We participate in INTEC expecting enquiries that we can later convert into business. This year has been particularly fruitful with quality people

from Coimbatore as well as from nearby areas like Tirupur, Salem, Trichur, and Kerala etc," added V Kumarvel, Senior Manager (Sales), Hindustan Hydraulics Pvt Ltd.

A visitor from Salem, an electrical engineer from Ashok Granites Ltd, N Jaganathan, said, "The show has lived up to its reputation of being well-organized. I get to see and gather information on emerging fields. This year, there is a stress on automation and robotics."

Innovations on display

Participating in trade fairs is the easiest way to gain access to a highly-targeted group of people, generate sales leads and receive

instant feedback. Hence, they serve as an ideal showcase for products and services. INTEC 2017 helped introduce several innovations including Beckhoff's embedded PC with many-core processing power and ultra-compact industrial PC ideal for applications with space and cost restraints; P+F's safety switches and controls and explosion protection for mobile devices used in hazardous industries; Gedee Weiler's Quattro Turn CNC Vertical Lathe and TRIAX 300 CNC lathe suited for mass production of large components up to 100 mm diameter using up to 8 tools.

There were others that were launched at the event itself including BR 45/22 cleaning machine ideal for highly small and blocked areas from Karcher Cleaning Systems; services for rapid prototyping, rapid tooling and on-demand manufacturing, Visuali by Redington3D; a comprehensive software solution for design engineering simulations, ANSYS AIM from Solid Trust Technologies; Autodesk Product Design Collection, a collection of software that performs 2D designs, 3D designs, factory designs, electrical designs etc. for complete design and as engineering tools from USAM CadSoft India Pvt Ltd.

A vision soon to be realized

Through the fair, efforts are underway to turn Coimbatore into a global manufacturing hub for an array of industries including automobiles, aerospace, agriculture, defence, railways, power, capital goods, consumer goods, space technologies. With the success, it's been garnering with each passing edition, this, however, doesn't seem to be too distant a reality. Mark your calendars for the next of its kind, which is scheduled to be held on June 06-10, 2019. 

Visitors at INTEC 2017 booths to learn the latest in innovation.



Source: CODISSIA



Source: VDW

Carl Martin Welcker, General Commissioner, EMO Hannover 2017 apprised the press during the preview.

A GLIMPSE ON EMO 2017

The Hannover Messe exhibition ground played host to the maiden EMO Press Preview, organised by VDW (German Machine Tool Builders' Association) on June 21, 2017. The curtain raiser on the world's largest trade fair for the metalworking industry, EMO Hannover 2017 was held exclusively for journalists from 30 countries to provide a lead-in on the latest production technologies that will be on display from Sept 18 - 23, 2017 in Hannover.

SOURMI MITRA
Editor-in-Chief
Modern Manufacturing
India
soumi.mitra@
magicwandmedia.in



2 017 is an EMO year! Post four-year break, this edition of the show will serve as the biggest global platform for manufacturers around the world to present their solutions for the challenges of industrial production and improve the competitiveness of the machine tool vendors. The exhibition's theme - "Connecting

Systems for Intelligent Production" is focused on providing benefits to customers from digitalization and networking of production operations. In this context, Carl Martin Welcker, General Commissioner, EMO Hannover 2017, provided an insight to the press on what to look for at the show. He elucidated that digitalization

has been implemented in the machine tool sector for a long time. "The task now is to network the entire production operation, including the complete added-value chain under Industry 4.0." President Frank-Walter Steinmeier, Germany, will grace the opening ceremony along with Stephan Weil, Prime Minister of Lower Saxony,



Source: VDW

From (L-R) Dr Wilfried Schäfer, Executive Director, VDW German Machine Tool Builders' Association; Carl Martin Welcker, General Commissioner, EMO Hannover 2017 and Dr Jochen Köckler, Chairman of the Managing Board, Deutsche Messe AG at the Press Preview.

and Luigi Galdabini, President, CECIMO on September 18.

Trendsetter for the industry

Acknowledged as an innovation forum, the fair has always been an ideal platform for launching new products and showcasing latest technologies. The participation of more than 2,050 firms from 45 countries in a daunting 177,000 sq mt of net exhibition area (in June 2017) is a testimony to it being a hot-spot for global metalworking sector. Interestingly, there is an increase of Asian exhibitors from the last edition's 21 to 25 percent. "There are plenty of indications

of EMO Hannover 2017 heading for a record participation level," shared Welcker with pride.

Following suit, the 2017 edition of the show will host a wide spectrum of presentations on commercial and technical issues including Industry 4.0; future production operations; additive manufacturing processes; metal-cutting in the aerospace sector; safety of machine tools; potential of the markets in the Americas, Mexico and India; start-ups for intelligent production; youth recruitment.

Captivating elevator pitch

What mostly matters in a preview is the first impression. Hence, each exhibitor was allotted a slot of 120 seconds to pitch their array of solutions that will be showcased in September during the elevator pitch. The 35 participating companies had their mini booths in the long sun-filtered corridor of the new hall in the exhibition ground. A snapshot on the offerings of the companies follow.

Agathon - Hall 11, Stand C62

It will present a new product line which allows an optimal

Around 143,000 visitors had come to EMO 2013 and 42 percent were from outside Germany and 80 percent were decision-makers.

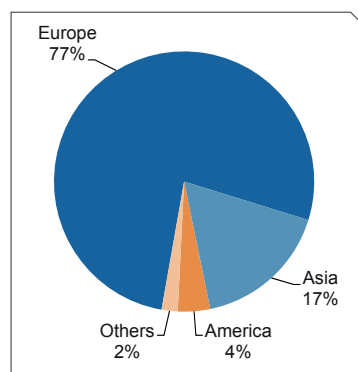

Source: VDW



INDIA @ EMO 2017

India's economy is expanding, as is its industrial production output. In 2016, the nation ranked eighth among the world's largest markets in the machine tool industry with a volume of € 1.7 billion. India imports around 70 percent of its machine tools to meet its requirements. A continued moderate increase in consumption of machine tools is predicted in 2017-18. In this backdrop, VDW is hosting 'India Day' to present the country's perspective on mechanical engineering, automotive and aerospace sector. Supported by the Ministry of Heavy Industry & Public Enterprises, Government of India, the 'India Day' will present the government's initiatives for boosting the manufacturing sector. V Anbu, Director General & CEO, Indian Machine Tool Manufacturers' Association, will present an overview of Machine Tool Industry in India. Also, there will be six delegations of high-ranking Indian entrepreneurs, organised and accompanied by various Indian customer associations and VDMA India.

To know more about the programme and register please visit www.emo-hannover.de/conference

Date & Time: **Sept 20, 2017 – 10.00 a.m. to 1.00 p.m.**

Venue: **Hannover Exhibition Grounds, Convention Centre, Hall 3 B**

Contact: **Bianca Huber, b.huber@vdw.de**

combination of different processing methods to improve productivity, flexibility and autonomy in the processing of super-hard materials. It is perfectly designed for the production of small and medium batch sizes.

Brailon Magentics - Hall 5, Stand D03

Its new PEPI electro-permanent lifting magnet is designed with an integrated control unit and push button control panel, fast and effective in multiple lifting applications. The PEPI lifting magnet is manufactured to safely and securely hold heavy



Source: YDWW

Journalists from nearly 30 countries meeting the exhibitors at their booths post-elevator pitch in the corridor of Hall 19 & 20 of the exhibition ground.

loads, from 3000kg to 8000kg on a flat finished surface especially for automation and robotic arms.

Castrol - Hall 7, Stand E23

It reinvented the fundamentals of cutting fluid technology by developing soluble cutting fluids that dramatically reduce the need for expensive treatment additives, biocides or fungicides. Castrol is launching this technology in two new metal cutting fluids for ferrous and aluminum alloys, Castrol Hysol SL 36 XBB and Castrol Alusol SL 61 XBB.

1 Dormer Pramet's Force AD range of versatile milling cutters and inserts.

2 The machines from are used for several applications like in wind power as depicted.

Dormer Pramet - Hall 3, Stand A64

This cutting tool manufacturer is participating at EMO for the first time post merger of Dormer Tools and Pramet Tools in 2014. The collective product range offered by the company represents a wide portfolio in the market, covering from solid to indexable, high speed steel to solid carbide and general purpose to application specific tooling.

Fair Friend Group - Hall 14, Stand G02

FFG's approach to Industry 4.0 is widespread. An overview of its various projects will be presented

at EMO including machine data analysis, tools for system engineering and integration, monitoring, service and support, and cloud-based open architecture SCADA systems.

Fresmak - Hall 3, Stand E58

It will be presenting its T-GRIP which is an adhesive clamping material and a family of clamping components capable to develop higher clamping and adhesion forces than any other alternative technology in the market, on any rigid material kind (ferromagnetic, non-ferromagnetic, composite.)

Heller - Hall 12, Stand C83

With HELLER4Industry, the company is offering an expanded solution range for the digitisation of production (Industry 4.0). It provides greater ease of use of the machine, optimal network integration and expanded functionalities and service possibilities.

Kaeser Kompressoren - Hall 12, Stand A36

The compressed air systems specialist will display its comprehensive innovative products and services. Kaeser is extending Industry 4.0

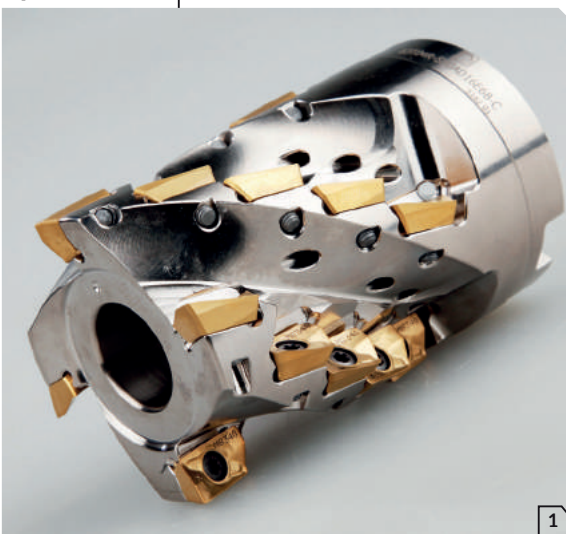

Source: Dormer Pramet

1

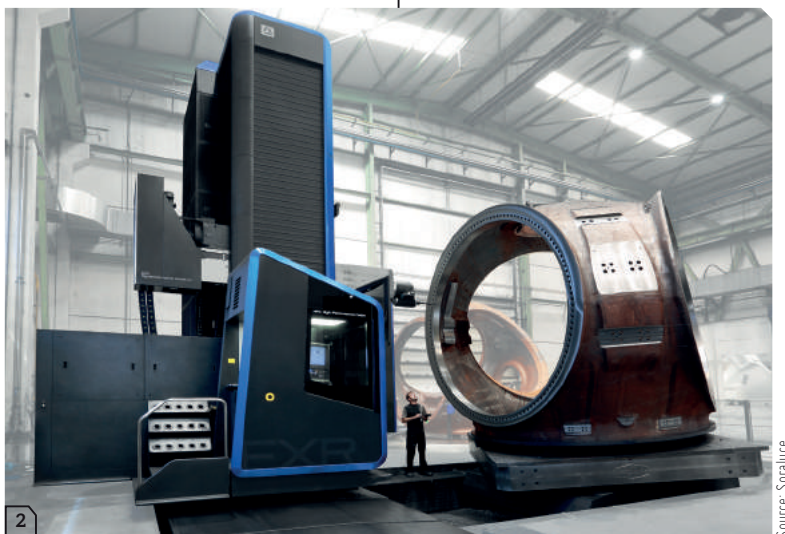

2

Source: Soratluce

Source: Volkswagen Nutzfahrzeuge



View of the new assembly line at the Volkswagen Hannover plant

Snapshot of Volkswagen Nutzfahrzeuge, Hannover Plant Visit

Since 1956, approximately 9 million vehicles have been manufactured in the Hannover Plant on a sprawling area of 1,091 million sq mt. The plant churns out the T series of the sixth generation Amarok, California (Limmer). Around 189,600 vehicles were produced in 2016 clocking a 7.5 percent growth as compared to 2015. The plant has its own foundry for component manufacturing to fulfill this huge demand. The plant houses one of the largest and most modern servo press lines in Europe which is approximately 194m in length, 42m in width and about 30m in height. The 24 bored piles (80cm in diameter) installed lend stabilization. They are made of 3200 tons of steel and 15,000 cubic meters of reinforced concrete and, under the 2.5m thick foundation, are approximately 35m deep. Total press force equals to 9,100 tons, making it a future oriented assembly.

capabilities to its smaller rotary screw compressor models (2.2 to 22 kW) so that users of these units can also benefit from seamless integration into Industry 4.0 environments.

Krause & Mauser - Hall 12, Stand C92

With its new PS MC machining centre, Krause & Mauser will present a machine that combines modern flexibility of a machining center with highest productivity and efficiency. Because of its open design, the PS MC is designed for modern production use in a digitized environment.

Liebherr-Verzahntechnik GmbH - Hall 13, Stand B76 & Hall 26, Stand A72

The criteria for an investment decision regarding a new gear cutting machine are primarily quality, maximum flexibility, and, at the same time, maximum productivity with low procurement costs. The LC 280 α is developed precisely to meet these requirements.

Ona EDM - Hall 13, Stand C86

Recognising that digital transformation is the next step, the company is applying the concept of Industry 4.0 to all its new machines with secure Ethernet connectivity, intuitive touch screen, easy-to-learn numerical controls and improved full monitoring package based on cloud computing.

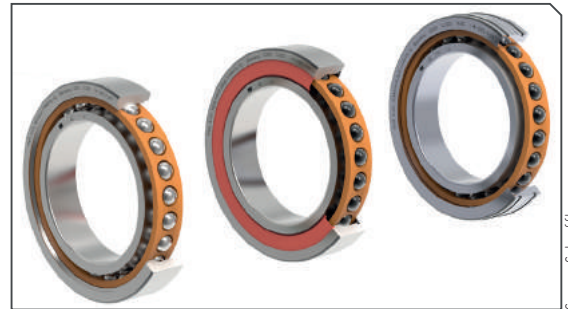

Source: Schaeffler

Sandvik Coromant - Hall 5, Stand B18

The future of machining and production is to take centre stage at the company's booth, spanning 528 sq mt. It aims to bring machining operations to the next level by offering new digital solutions and enabling the connection of processes, with the focus on optimizing the machining process and decision-making to increase profitability.

Schaeffler - Hall 7, Stand C42

With these new X-life high-speed spindle bearings, spindle manufacturers can significantly increase the mechanical and thermal load carrying capacity of their existing product series without changes to the design. The new series opens up entirely new levels of design freedom,

The new M, HCM, and VCM series of FAG spindle bearings in X-life quality for increased mechanical and thermal load carrying capacity.

Global machine tool consumption rises more steeply after an EMO show.

WORLD MARKET FOR MACHINE TOOLS

Bill. EUR, 2017 forecast

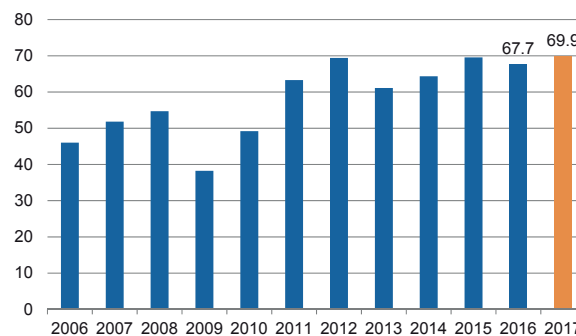

Source: VDW

% change to previous year

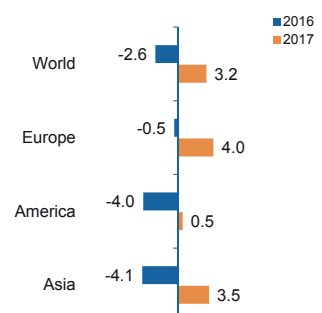

Sources: Data up to 2016: VDW, Forecast 2017: Oxford Economics, Global Machine Tool Outlook, Spring 2017



Source: FFG

VDF Boehringer lathes and turning centers cover a full range of railway applications, from wheelset or wheel repair to production of new axles

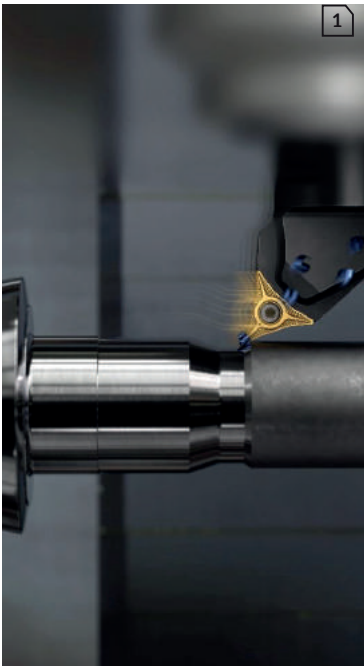

Source: Sandvik Coromant

1

1 Sandvik Coromant will present the new PrimeTurning method and its corresponding CoroTurn Prime turning tools at EMO 2017

2 Liebherr is opening a new chapter in the evolution of gear hobbing.



Source: Liebherr-Verzahntechnik GmbH

2

thanks to its high-performance VCM version.

Siemens - Hall 25, Booth D60

Under the banner of "Digitalization in Machine Tool Manufacturing", Siemens will be demonstrating how machine tool manufacturers and operators of all sizes can benefit from the digital revolution with the Digital Enterprise Suite. It will feature new operating concepts, machining functions and multi-technologies for the machine tool control system SINUMERIK.

Soraluce - Hall 13, Stand B36

Acknowledging the importance of new digital paradigm in manufacturing that makes the interaction between machines, people and processes easier, Soraluce has taken its range of machinery and solutions to a new level of competitiveness with high value-added services intended to increase the availability and productivity of the solutions that it offers.

TDM Systems - Hall 5, Stand B18

The company will ring in the

age of Industry 4.0 with its new 3D tool assembler in TDM 2017 Global Line and the tool search, which is similar to a simple Internet search. The new TDM-check examines data and the data structure of the TDM application and displays areas of potential improvement.

United Grinding - Hall 11, Stand B24

With the MFP 51 5-axis grinding machine MÄGERLE will present a new grinding center setting new standards in terms of flexibility and equipment features. In its basic version, this sturdy grinding center comes with an integrated tool changer in a gantry design with 66 positions. The scalable tool magazine can be additionally adapted to customer requirements in the project planning phase. The magazine can be flexibly loaded with various grinding wheels, diamond rolls, measuring probes and tools for drilling and milling operations.

Vollmer Werke - Hall 6, Stand F46

Sharpening specialist Vollmer will be showcasing its product and service portfolio under the motto "Dialogue on Precision". Its grinding and erosion machines can be used to sharpen and machine circular saws, band saws and rotary tools.

Paving the way for future

Our visit at the futuristic Volkswagen Nutzfahrzeuge, Hannover Plant the following day of the Press Preview provided us an opportunity to witness the innovative capabilities that the machine tool sector offers in the environment of digitisation. With days numbered for the EMO Hannover 2017, the countdown has already begun!



TAIWAN

MACHINE TOOLS SHAPING THE WORLD

EARTH



10 August, 2017

Taiwan Machine Tool Press Conference

14:30pm at Hall 12A Foyer
Pragati Maidan, New Delhi

10-13 August, 2017

Welcome to Taiwan Pavilion

Hall 12A
A111, A121, A123,
B122-B124, C114

Hall 12
B113

Contact:
Taipei World Trade Center
Liaison Office in Mumbai
Tel: 91-22-2216-3074
Email: mumbai@taira.org.tw



www.twmt.tw

Sponsored by



Bureau of Foreign Trade, MOEA

Organized by



Taiwan External Trade Development Council



Corporate Synergy Development Center

CONQUERING THE SUMMIT

The highest performing companies have certain practices deployed that qualify them better from the rest. To identify their approaches and aid the others in applying the same for significant performance effects, the Indian Machine Tool Manufacturers' Association (IMTMA) has organized the 11th edition of National Productivity Summit on August 04-05, 2017 at Hyatt Regency, Pune. Save the dates.



Source: IMTMA

Industry leaders as speakers at the National Productivity Summit 2016.

With the aim to build a sustainable competitive advantage, companies are constantly striving for means to increase their growth, reduce cost of operations, and enhance productivity. They are persistently on a lookout for a highly structured approach to managing innovation, while at the same time, not losing out on time to reach the markets.

Although technological advancement, blurring the boundaries between the physical and digital manufacturing worlds, has become a key facilitator in this pursuit, challenges in the Indian manufacturing industry exist by and large.

Through this summit, IMTMA has thus taken on the role of a torchbearer to address the

issues the industry faces in regard to productivity and competitiveness.

Girish Shankar, Secretary, Department of Heavy Industry, Government of India will grace the event as the Chief Guest. Prasan Firodia, Managing Director, Force Motors and Shishir Joshipura, Managing Director, SKF India will be the Guests of Honour.

The summit in a nutshell

The National Productivity Summit through Keynotes, Case Study Presentations and Plant Visits, showcases the practices deemed best in the world of manufacturing.

The event brings forth reasons why manufacturers should embrace integrated approaches for optimizing manufacturing

productivity, and suggests ways for preparing their people, processes and technology as part of this journey of productivity excellence.

Plant visits for enhanced learning

The summit has lined up plant tours to high-performing companies as part of its agenda. Observing and assessing their plant processes up close give a thorough understanding of the company's performance potential, and aid in applying their proven shopfloor practices to one's own plant.

- HENCE, three assessment tours have been planned prior to the summit on Aug 3, 2017:
- ▶▶ Tour A to Spicer India and Bosch Chassis Systems India;
 - ▶▶ Tour B to Cummins India and Tata Cummins;
 - ▶▶ Tour C to Mahle Behr India and Concentric Pumps.

Learning from their expertise

Through the plant visits participants will have an excellent opportunity to learn manufacturing processes that go into making Cummins India's mid high horsepower engines for

POONAM PEDNEKAR
Chief Copy Editor
Magic Wand Media Inc
poonam.pednekar@
magicwandmedia.org



off-highway applications or Tata Cummins' mid-range engines for on-highway applications. Bosch Chassis Systems' braking system components and vehicle safety systems for the automotive industry and Spicer India's axles, driveshafts and drivetrain products will be easier to comprehend after the tour to these companies. Mahle Behr India's expertise lies in making automotive air conditioning and engine cooling systems, while Concentric Pumps is into advanced technology oil pumps, water pumps, fuel pumps and hydraulic systems. The tours will provide clarity as to why and how the companies are leading in innovation and sustainability.

Keynotes that will motivate

As part of the summit, industry leaders will be sharing their expertise and experiences. Sunil Kaul, Group President, Excellence in Manufacturing, Innovation and Technology, ANAND Automotive, will reveal the "Quality Culture at ANAND - Leader Led Transformation for Zero Defect".

Dattatreya Gaur, Vice President and Business Unit Head, Robert Bosch Engineering and Business Solutions, will enlighten on the "Relevance of Smart Manufacturing in the Indian Context".

Ravi Damodaran, President, Technology & Strategy, Varroc Engineering, will be presenting his take on the "Challenges in Manufacturing Productivity - The Way Forward".

Challenges and solutions

Challenges are rife in the manufacturing world. What is not so common is the ideal way to deal with them. Successful companies are ahead in the race due to their innovative approaches to finding ways out

of problems. The event aims to highlight them through their case study presentations. To name a few: Bajaj Auto, Akurdi, will share its innovatively developed Garnet Shot Blasting setup in place of a purchased steel shot blasting machine for welded sheet frame. The result of which is a 92 percent drop in its inventories and 100 percent increase in productivity besides lower capital and process costs. Mahindra & Mahindra, Kandivali, will make aware of its almost impossible feat of converting an existing Hot Core box to Cold box process to make shell cores without stopping production for a single day. Mahle Behr India, Pune, will demonstrate how 100 percent line balancing can be achieved in an assembly line. Titan Company, Hosur, will elaborate on how the use of innovative progressive die design resulted into four different watch components from a single die, with 90 degree indexing of die and use of two parallel strip feeds.

May the best one win

Awards are the best way not just to recognise one's excellence, but also to acknowledge one's abilities, the struggle one goes through and the commitment needed before making it to the

top slot. The summit through the IMTMA - ACE MICROMATIC Productivity Championship Awards 2017 will reward outstanding efforts from the shortlisted case studies of companies that have excelled in achieving superior performance. Cash prizes worth ₹10 lakh will be presented to the winners.

A not-to-be-missed affair

The event makes an ideal platform to learn from the industry experts as they shed light on the practices they execute in their presentations and case studies. Plant visits provide an exposure to the shop floor practices of the renowned companies in the industry, while the interactive sessions and networking help exchange new ideas and concepts that will usher in a fresh perspective.

Hence, CEOs, top management executives, senior executives, engineers, R&D specialists and industry consultants from manufacturing industries from Automotive, Auto components, Consumer durables, Machine tool, Tool rooms, Aerospace, Defence, Railway units, PSUs, General engineering and other discrete manufacturing industries should participate in the event and make the most of the takeaways.



IMTMA - ACE
MICROMATIC
Productivity
Championship
Awards are for
rewarding
outstanding efforts of
excelling companies.



Source: IMTMA

AN IMPETUS TO THE MANUFACTURING SECTOR

The phenomenal success of the first edition of the Delhi Machine Tool Expo (DMTX) made Indian Machine Tool Manufacturers' Association (IMTMA) organise the second edition with an objective to bring together small and big industry players, stalwarts and industry experts under one roof. The show is scheduled to take place from August 10-13, 2017 at Pragati Maidan, New Delhi.



A glimpse of DMTX 2015.

Source: IMTMA

edition of the expo organized in 2015 evoked a warm response with the presence of several domestic and international players. Manufacturers were able to expand their range. The second edition will enable them to build on the earlier success and reach out to the regional industries."

Expressing his expectations from the show, V Anbu, Director General, IMTMA, stated, "IMTMA is eyeing a bigger success in this edition. We expect a larger level of participation across various industry sectors and I am confident that the expo will continue to evolve in its future editions."

A peek into the latest

The show, spread over an area of 12,000 sq mt, will accommodate 200 exhibitors in the three of its halls (Hall 11, 12 and 12A). It will cover a wide array of metal working machine tools for both metal-cutting and -forming including the current trends in manufacturing like automation and robotics, tooling systems and CAD/CAM.

The exhibits will include Turning machines; CNC multi-function machines; Drilling,

Despite being a hub to major engineering and machine tool industries, manufacturers in northern states of Delhi, Haryana, Punjab, Uttar Pradesh, Rajasthan, Uttarakhand, etc. still lack the much-needed exposure to global manufacturing trends and innovations. DMTX, with its reach, aims to fill that gap and provide a platform for these manufacturers, especially the SMEs of the tier II and III cities of the region, to witness the current

technologies and solutions, address their issues and enhance their manufacturing capabilities.

Repeating history

Having garnered favorable reviews for the previous edition from the participants and the industry, the organisers have made sure not to leave any stone unturned to do it right this time too. In fact, more efforts are poured in to surpass last time's success. PG Jadeja, President, IMTMA, elaborated, "The first

POONAM PEDNEKAR
 Chief Copy Editor
 Magic Wand Media Inc
 poonam.pednekar@
 magicwandmedia.org





“The first edition of the expo organized in 2015 evoked a warm response with the presence of several domestic and international players. Manufacturers were able to expand their range. The second edition will enable them to build on the earlier success and reach out to the regional industries.”

PG Jadeja
President
IMTMA

Boring, Tool Grinding and Milling machines; Screwing and threading machines; Honing, Lapping, Polishing and Deburring machines; Electro erosion machines; Robotics and manufacturing automation; Machines for marking; Machine tools for educational purposes; Sheet metal cutting machines; Sheet metal blanking; Punching machines; Machines for the production of bolts, nuts, screws and rivets; Joining and welding; Robotics and manufacturing automation; Automation for storage and transport; and Dies and moulds.

METROLOGY and WELDEXPO

For the first time DMTX has integrated two concurrent shows: METROLOGY EXPO for testing instrument, metrology and equipment; and WELDEXPO for welding, cutting and joining. In today's complex manufacturing process, accuracy and precision plays an important



“IMTMA is eyeing a bigger success in this edition. We expect a larger level of participation across various industry sectors and I am confident that the expo will continue to evolve in its future edition.”

V Anbu
Director General
IMTMA

role to define the quality of finished products, which require high level of detailing and low tolerance. When components are machined the process is not completed unless it is measured. Accomplishing the needs of the end customers with quality output can be achieved only after measuring and certifying the end product for its suitability at the customer's end. A separate pavilion on the Metrology & Measurement will address the needs and provide various innovative and technological solutions for manufacturing. Similarly, WELDEXPO is held at an opportune time since the recent development of new automated manufacturing methods has made the process more important than ever before. Technologically advanced processes are improving the results of welding and making it applicable to a wider range of manufacturing applications such as pressure vessels, aircrafts, ships and

medical devices to high volume products such as automotive parts, appliances, food packaging and microelectronics.

An august gathering

Delhi MTX 2017 is poised to be a business facilitator between manufacturers and users associated with metal-cutting and -forming industry. Hence, it makes an important affair for players of all levels including CEOs, entrepreneurs, middle-level management, senior executives, corporate planners and strategists, R&D specialists, manufacturing managers and executives, shop-floor engineers, supervisors and technicians, agents and dealers, spanning industries such as Capital Goods, Material Handling, Medical Engineering Defence, Aerospace, Railways, Automobiles, and Oil & gas. Apart from India, seven foreign countries: Czech Republic, Germany, Italy, the USA, China, Taiwan and Australia are expected to participate. Three of these, China, Taiwan and the USA will have group participation.

Palette of offerings

For Jyoti CNC, DMTX makes for an ideal platform to exhibit its

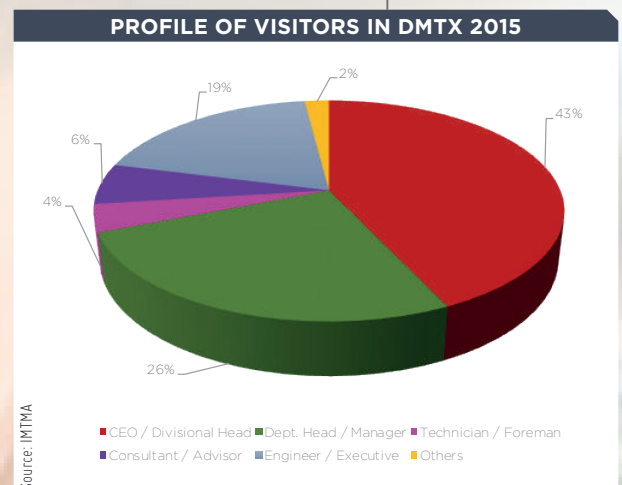



“With high quality, machining flexibility, competitive prices and good after-sales service, Taiwan machine tool makers can help Indian manufacturers make better products and improve their business.”

Michael Lin
Director
TAITRA

products with respect to specific industry segments dominant in the northern region. Delhi being a hub to major manufacturing industries, makes it a strategic location to connect with the industries in the surrounding states.

“We look at DMTX as an opportunity to exhibit our technologically advanced products with specific focus on specific industrial segments of the region such as the Automobile, Die & Mould, General Engineering, Tractor, Energy and the two-wheeler sector,” stated Himanshu P Shaparia, Vice President - Sales, Jyoti CNC Automation Ltd. The company, through the event, wants to connect with and address the needs of the SME sector which is a dominant force in our country. The company will be displaying its upgraded turning centers and machining centers as complete solutions for the SME sector.

UCAM, an established market leader in India in CNC Rotary Table segment, plans to reach out



“DMTX show plays a pivotal role in reaching out to our customers, primarily in and around states closer to the NCR region.”

Ramesh TK
Director
UCAM Pvt Ltd

to its pan India customer base, existing and potential, through DMTX. At the event, it will be showcasing its customized high precision Gear Hobbing and Grinding machines that would strategically support gear manufacturers in the Indian sub-continent, apart from presenting its wide range of standard and specialized CNC Rotary Tables.

Taiwan External Trade Development Council (TAITRA) hopes that the Indian market will open the door wider for Taiwanese industry and investment. The Taiwan Pavilion will house CNC machine tools, tool holders, cutting tools, riveting machines and various machine tool accessories. To help local buyers know more about Taiwan's machining equipment, turnkey solutions and after-sale support, TAITRA is organising a press conference on August 10 at the exhibition venue.

A not-to-be-missed affair

Since DMTX is a business to



“In line with our mantra of being customer centric, our focus at DMTX is meeting our existing customers and acquiring new customers to strengthen and expand our network.”

Himanshu P Shaparia
Vice President - Sales
Jyoti CNC Automation Ltd

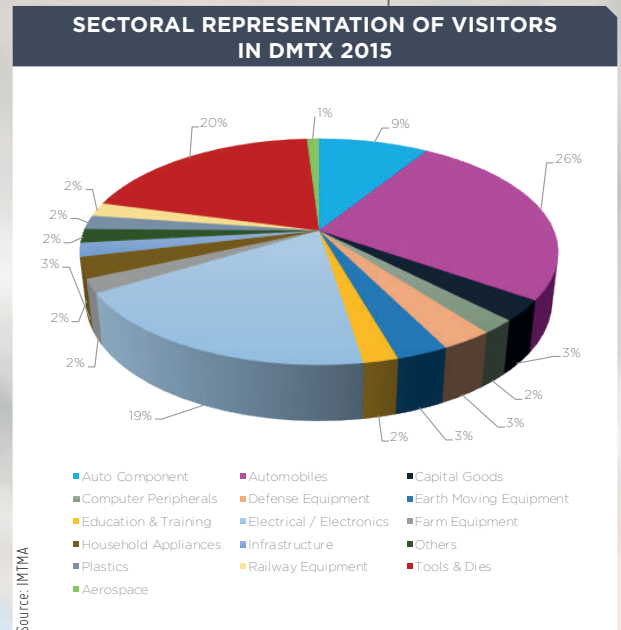

business exhibition, it will draw industry delegations from a wide variety of sectors. Apart from imparting knowledge on the technology innovations in manufacturing, the event also offers a platform to mingle with like-minded players of the industry opening new vistas of opportunities.



Metrology

Intelligent Process Control Software

Improved capability in precision part machining, reduced setting and process adjustment time, and integration with automation systems are some of its benefits.

The Renishaw Equator flexible gauge is offered with IPC (intelligent process control) software, providing the functionality to fully automate tool offset updates in CNC manufacturing processes. IPC is used with the existing software running on the Equator controller, using recent historical gauging data to determine process corrections. Connection to a compatible machine tool can be as simple as connecting an Ethernet cable from the Equator to a CNC machine. This capability has already been used by Renishaw customers worldwide to achieve performance gains across a variety of industries, applications and CNC machine types, including lathes, machining centers and highly automated machining cells. The new IPC software allows constant monitoring and adjustment of a machining operation, keeping part dimensions close

to nominal and well within process control limits.

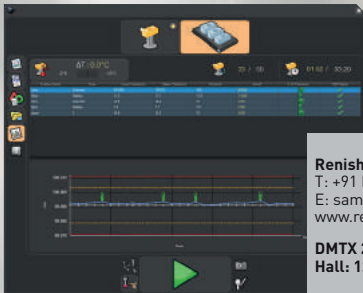

Renishaw Metrology Systems Ltd
T: +91 (20) 6674 6200
E: samina.khalid@renishaw.com
www.renishaw.co.in

DMTX 2017
Hall: 12 / Stall: B109

Inserts and Cutters

Double-Sided Inserts for Double Benefits

The range is particularly recommended for machining components in Automotive and General Engineering, though it has extensive applications across most industries.

The all-new 16 cutting edge, double-sided, octagonal ONMU range of inserts and cutters from DURACARB is a versatile tool designed with helical geometries on the insert, and positive rake angle pocket on the cutter body. This results in reduced cutting forces during machining, giving it the ability to machine at high feed rates on both low power and high power spindle machines. The inserts are available in two sizes: ONMU 05 for low depth of cut, low spindle power machines and ONMU 07 for moderate to high depth of cut and high spindle power machines. They are available in two chip geometries namely ML and M for better machining, as also in grades DC9800, DC9200, DP5035 ideal for machining Steel, SS and Cast Iron. Cutters are available in diameters 63mm to 160mm, while end mills in diameters 25mm and 32mm.



TaeguTec India Pvt Ltd
T: +91 080-4901 3000
E: sales@taegutec-india.com
www.taegutec-india.com

DMTX 2017
Hall: 11 / Stall: B102

Complex Machining

Machining Center for Critical Components

It is ideal for highly complex components used in Aerospace, Die & Mould, Oil & Gas and Medical industries.

The JU 40, from Lakshmi Machine Works Ltd, is a 5-axis simultaneous machining center. This machine completes high accuracy complex components in a single setup, ensuring easy and quick production of close tolerance components. It is ideal for highly complex components for Aerospace, Die & Mould, Oil & Gas and Medical industries.

The JU 40 comes with a BBT40 spindle taper and direct driven 12,000 rpm spindle. The machine has a Ø500 x 400 mm tilting rotary table with A & C axis and X, Y, Z axis travel of 400 mm, 550 mm & 550 mm respectively. Excellent repeatability, high reliability and performance are the key features of this machine. LMW has been continuously upgrading its capabilities to tackle the manufacturing issues faced by a variety of industries that is to produce parts of varying material compositions, volumes and complexities. The company has come up with the solution in the form of JU 40.



Lakshmi Machine Works Ltd
T: +04 (22) 302 1393
E: bhattacharya.i.n@lmw.co.in
www.lmwcnc.com

DMTX 2017
Hall: 11 / Stall: B121

Your magazine
is back with a
**new
look!**



The Official Magazine of



Indian Machine Tool
Manufacturers' Association

In Association with



**MODERN
MANUFACTURING
INDIA**

WWW.MMINDIA.CO.IN

**BOOK
YOUR SPACE
NOW!**

CONTACT:

**M: +91 9740048390
+91 9870401498**



Company Index

Ace Designers	37
Ace Micromatic	65
ACMA	36
advanced clean production GmbH	48
Agathon	58
Beckhoff Automation Pvt Ltd	46
Brailon Magentics	58
Castrol	58
CODISSIA	55
Complexus Medical	50
Dormer Pramet	58
EEPC India	35
Ferromatik Milacron India Ltd	10
Fair Friend Group	58
Fraunhofer IPA	18
Fresmak	58
Heller	58
HMT Machine Tools Ltd	42
Hybrid Manufacturing Technologies	46
IEEMA	35
IMTMA	6, 8, 12, 58, 64
Isgec Heavy Engineering Ltd	31, 38
JFMA	31
JMTBA	31
Jyoti CNC Automation Ltd	37, 68
Kaeser Kompressoren	58
Kennametal India Ltd	36
KOMET America	40
Krause & Mauser	58
Liebherr-Verzahntechnik GmbH	8
Lakshmi Machine Works Ltd	2, 3
Micromatic Grinding Technologies	10
Micromatic Machine Tools Pvt Ltd	14
Ministry of Heavy Industries & Public Enterprises	34
Ona EDM	58
Renishaw Metrology Systems Ltd	69
Sandvik Coromant	58
Schaeffler	16, 37, 58
Siemens	58
Soraluce	58
TaeguTec India Pvt Ltd	35, 69
TAITRA	68
TDM Systems	58
UCAM Pvt Ltd	36, 68
United Grinding	58
VDMA India	36, 58
VDW	58
Vollmer Werke	58
Yamazaki Mazak India Pvt Ltd	37
Yuken India Ltd	42
Zavenir Kluthe Group	16

Advertiser Index

Ace Manufacturing Systems Ltd – www.amsl.in	9
ACMEE 2018 – www.acmee.in	11
Apex Precision Mechatronix Pvt Ltd – www.apexprecision.co.in	15
Beckhoff Automation Pvt Ltd – www.beckhoff.co.in/cnc	17
EXCON 2017 – www.excon.in	2
IMTMA - Delhi Machine Tool Expo – www.mtx.co.in	23
IMTMA - IMTEX 2018 – www.imtex.in	71
IMTMA - National Productivity Summit – www.productivity.imtma.in	45
INTEC 2019 – www.intec.codissia.com	31
Jyoti CNC Automation Ltd – www.jyoti.co.in	3
Mitsubishi Electric India Pvt Ltd – www.mitsubishielectric.in	7
TaeguTec India Pvt Ltd – www.taegutec-india.com	72
TAITRA – www.taitra.org.tw	63
Yamazaki Mazak Pvt Ltd – www.mazakindia.in	26-27



Make it possible



International Forming Technology Exhibition



International Exhibition of Dies & Moulds, Forming Tools,
Machine Accessories, Metrology and CAD / CAM

25 - 30 January 2018, Bangalore, India

Organiser



Indian Machine Tool
Manufacturers' Association

Venue



Bangalore
International
Exhibition Centre



www.imtex.in

INTRODUCING SMART SOLUTIONS FOR PARTING AND GROOVING

- Extensive range of grooving and parting system.
- Economical twin-edged inserts with high stability and good repeatability.
- Molded chipbreaker.
- Top and bottom prism on insert hold the insert firmly and aligned accurately.
- Very rigid seating with strong and secure clamping.
- Simple, accurate and rapid indexing.
- Stable support against side forces.
- Integral shank tools with minimum spare parts, in standard shank dimensions.
- Smartest solution for deep grooving, parting, shallow grooving, recessing, undercutting etc.

New D-CUT

PARTING • GROOVING

Two exclusive geometries to cater to a wide range of applications.

WHEN
COST SOUNDS LIKE A
FOUR-LETTER
WORD...
TURN TO OUR TOOLS! 

Member IMC Group
Duracarb

Smart Indian Choice

sales@duracarb-india.com