



MODERN
MANUFACTURING
INDIA

WWW.MMINDIA.CO.IN

The Official Magazine of



Indian Machine Tool
Manufacturers' Association

In Association with



CLEARING THE AIR

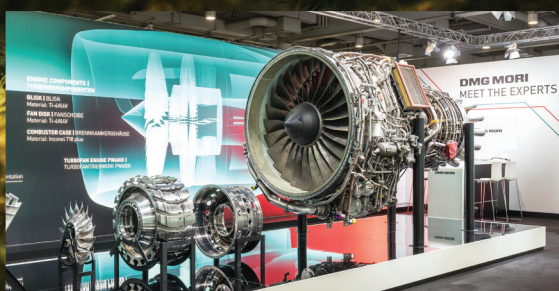

AEROSPACE COMPONENTS
Excelling in the Air

38 INDIA @ EMO
Getting Future-Ready



34 DR HEINZ-JÜRGEN PROKOP
Chairman, VDW



CNC Tilting Rotary Table



CNC Rotary Table

YOUR PARTNER IN PRODUCTIVITY

4th & 5th AXIS SOLUTIONS

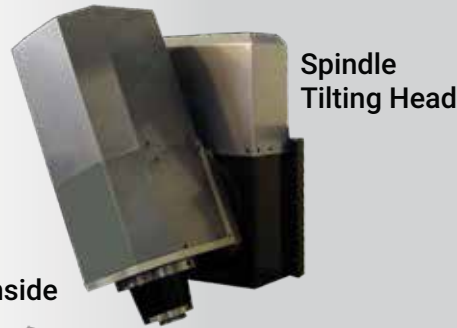
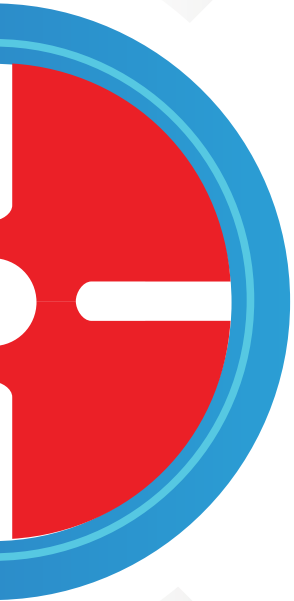

Spindle
Tilting Head

Rotary Table Inside
Machine Bed

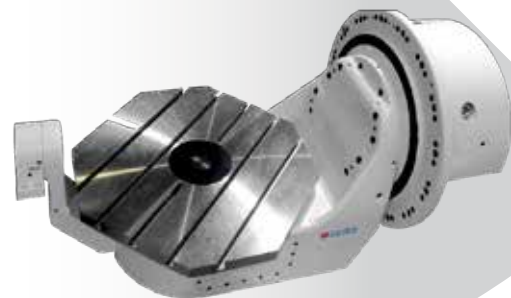

Cantilever Table

VISIT US @



HALL : 12
STAND : E90

Catalogue range products

Custom built products

Competitive



Dealers solicited across the globe

CONTENTS

VOL 3, ISSUE 3, SEPTEMBER-OCTOBER 2019



20



42

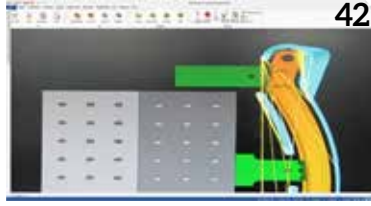

46



60



- | | |
|--|---|
| 06 FOREWORD | 34 INDIA @EMO
Getting Future-Ready |
| 08 PUBLISHER'S NOTE | 38 AEROSPACE COMPONENTS
Excelling in the Air |
| 10 EDITORIAL | 42 CAD/CAM
The Sky's the Limit |
| 12 IMTMA'S DESK
Survival Strategies in
Economic Downturn | 46 COMPANY PROFILE
Staying Close to the Customer |
| 14 IMTMA'S DESK
Strengthening SMEs for
a New India | 48 IIoT
A World Language for Machines |
| 16 NEWS | 54 SME SUCCESS
Doing More with Less |
| 18 EMPLOYMENT OPPORTUNITIES | 58 EVENT SNAPSHOT
LiveWorx 2019 |
| 20 INSIGHT
Soaring to New Heights | 60 EVENT SNAPSHOT
DMTX 2019 |
| 24 PANORAMIC PERSPECTIVE
Why Trade Shows Must Go On | 64 EVENT SNAPSHOT
NPS 2019 |
| 26 COVER STORY
Clearing the Air | 68 PRODUCTS &
SUBSCRIPTION FORM |
| 32 BIG INTERVIEW
Dr Heinz-Jürgen Prokop
Chairman
VDW (German Machine Tool
Builders' Association) | 70 COMPANY &
ADVERTISER INDEX |

IMPRINT

PUBLISHER & DIRECTOR GENERAL & CEO,
IMTMA
V Anbu

EDITORIAL

Editor-in-Chief
Soumi Mitra

Chief Copy Editor
Poonam Pednekar

Correspondent
Arunima Nath

Design

Magic Wand Media

SALES & MARKETING

Indian Machine Tool Manufacturers' Association
Murali Sundaram, Magic Wand Media Inc
murali.sundaram@magicwandmedia.in

Published and Printed by V Anbu on behalf of Indian Machine Tool Manufacturers' Association (IMTMA). Printed at Pentaplus Printer's Pvt Ltd 20/1, 4th main, 5th cross, Industrial Town, Rajaji Nagar, Bangalore-560044, Karnataka and Published from Indian Machine Tool Manufacturers' Association; Head Office: 10th Mile, Tumkur Road, Madavara Post, Bengaluru - 562123, Karnataka. Editor: Soumi Mitra

Publishing frequency: 6 times per year

Manuscripts: No liability is accepted for unsolicited manuscripts. They will be returned only if accompanied by sufficient return postage.

All rights reserved. Reprints, digital processing of all kinds and reproduction only by written permission of the publisher. Any views, comments expressed are the sole responsibility of the respective authors, IMTMA and Modern Manufacturing India and its partners do not undertake any responsibility, implied or otherwise.

Disclaimer: Every effort has been taken to avoid errors or omissions in this magazine. In spite of this, errors may creep in. Any mistake, error or discrepancy noted may be brought to our notice immediately. It is notified that neither the publisher, the editor or the seller will be responsible in respect of anything and the consequence of anything done or omitted to be done by any person in reliance upon the content herein. This disclaimer applies to all, whether subscriber to the magazine or not. © All rights are reserved. No part of this magazine may be reproduced or copied in any form or by any means without the prior written permission of the publisher. All disputes are subject to the exclusive jurisdiction of competent courts and forums in Bangalore only. While care is taken prior to acceptance of advertising copy, it is not possible to verify its contents. IMTMA cannot be held responsible for such contents, nor for any loss or damages incurred as a result of transactions with companies, associations or individuals advertising in its newspapers or publications. We therefore recommend that readers make necessary inquiries before sending any monies or entering into any agreements with advertisers or otherwise acting on an advertisement in any manner whatsoever.

ECONOMICAL, PRECISE, QUICK

- THE AMF ZERO-POINT SYSTEM

By using modern AMF zero-point systems, optimize fixture and workpiece changeover in production, correspondingly reduce set-up times on the machine and so save money!

The benefits of zero-point clamping technology are obvious:

- > Increase in machine run-time
- > Very fast workpiece or fixture changeover
- > High repeatability
- > A uniform interface for all machines
- > Positioning and clamping in a single step

Numerous advantages speak for themselves and make the AMF zero-point system a technology that revolutionizes the zero-point clamping market.

14th **ENGIMACH**
4|5|6|7|8 DEC 2019
The Exhibition Centre, Gandhinagar, Gujarat, INDIA
HALL-11 STALL-65

AMF
Quality Since 1890



ANDREAS MAIER WORKHOLDING TECHNOLOGY PVT. LTD.

(Subsidiary of : AMF - GERMANY)

116, 2nd Cross, NHCS Layout, Basaveshwaranagar, BENGALURU-560079, INDIA

Phone: +91 80 2323 8444 E-mail: amfindia@amf.de Web: www.amf.de



nano

AVAILABLE
FROM Ø 0.3MM



threading

MEGA

UP TO Ø 160MM



DC SWISS SA
Grand-Rue 19
CH - 2735 Maleray
Tel. +41 32 497 63 38
mayur.kulkarni@dcswiss.ch
dcswiss.com



**MAYUR
KULKARNI**



**DOWNLOAD
OUR CATALOGUES**



VISIT US AT

EMO Hannover
16-21.9.2019
The world of metalworking

**HALL 004
BOOTH E27**

 SWISSMADE



P RAMADAS
PRESIDENT
IMTMA

SWIMMING AGAINST THE TIDE

We are witnessing some challenges in the economy, especially in the automotive sector, which is undergoing some major disruption with the Government's push for electric vehicles and a slowing down in demand for petrol and diesel variant vehicles.

Testing times are ahead for the Indian machine tool industry as it depends on the automotive industry for its growth and sustenance. Although, I am optimistic that markets will open up in the coming quarters and the industry will bounce back with the improvement in economy, the machine tool sector, for now, needs to stay focused and united to face the challenges that are confronting it.

Indian Machine Tool Manufacturers' Association (IMTMA) has been advocating on various fronts for an increased Government spending on infrastructure to generate demand for machine tools. Furthermore, considering the rapid changes in technology, reduced lifecycle of products and for getting an investment allowance to spur demand for new machine tools and equipment, the Association has been advocating for a higher 25 percent depreciation for machine tools.

The Indian manufacturing industry has a significant presence of SMEs that are large consumers of machine tools. Suitable measures to extend credit to SMEs and connected financial reforms will help them and the the manufacturing sector.

Measures such as development contract and relaxation of prior supply condition in Government tenders will help the Indian machine tool industry in developing advanced technology and products and open up export opportunities.

Moving on, the industry should look for exploring opportunities in emerging sectors such as defence, space, aerospace, medical equipment, railways, etc. which are expected to grow rapidly in the coming years. I would strongly advocate our friends in the industry to continue their efforts to address the technological requirements of these new and emerging industries.

Exhibitions always serve as a link for the development of trade and serve as platforms for industries to connect with the technological developments taking place globally. Keeping this broader vision in mind, IMTMA organizes regional machine tool expos in different cities in India to serve the needs of the regional markets. These expos attract visitors from various industries especially SMEs which can benefit from such shows.

The third edition of Delhi Machine Tool Expo (DMTX 2019) concluded successfully. The exhibition attracted around 6,000 visitors and trade delegations from various industry sectors. I would like to state that these two years for me as IMTMA President has been an enriching experience. This was made possible due to the proactive assistance of IMTMA's Executive Committee and Membership, and enduring guidance and contribution of all the Past Presidents.

As a note of conclusion, I am sure that deep commitment and earnest endeavour of the Association, its Executive Committee and Membership will lead IMTMA to greater achievements in the coming years.

Happy reading!

DYNASCAN

Rapid Profile Projector

The Next Generation . . .

- Instant Image Grab in Seconds
- Smart, Fast, Easy, Accurate
- Automatic, Non Contact, Pass / Fail Reports
- Measure, Tolerance, Sort, Reverse Engineer

DYNASCAN INSPECTION SYSTEMS COMPANY
Electronic City, Bangalore

sales@dynascan.info ▪ Website: www.dynascan.info

▪ Bangalore: 9741109039 / 97411 09029 ▪ Pune / Delhi: 9743411700 ▪ Chennai: 9743027722



Rapid Profile Projector
Horizontal 400 H



Ministry of Micro,
Small and Medium
Enterprises
Govt. of India

MSME - TOOL ROOM, KOLKATA

(Central Tool Room & Training Centre)

Under Ministry of Micro, Small & Medium Enterprises, Govt. of India
Bonhoogly Industrial Area, Kolkata - 700 108, Ph.: 9038578065 / 9330193304
9830487179 / 2578-8769, E-mail: cttc@cal.vsnl.net.in, Website : msmetoolroomkolkata.com



ISO 9001:2015
OHSAS 18001 : 2007
CERTIFIED

**FREE FOR
ST / SC CANDIDATE**

ADMISSION NOTICE

**15% Discount
for All General Candidate**

Applications are invited in the prescribed form from intending candidates for admission to the following Courses

POST DIPLOMA IN INDUSTRIAL AUTOMATION AND ROBOTICS (PDIAR) (Approved by NSQF Level - 6)

Duration : 1 year **Course Fee** : Rs.61,500/-
Eligibility : Diploma or Degree in ME, EE, ECE and equivalent

COURSE CONTENT : **SEMESTER-1** : Programmable Logic Controller
• SCADA • HMI • Hydraulics & Pneumatics • Electrical Cad • Power
Electronics • Drives **SEMESTER-2** : Electrical Circuits & Paneling • Process
Instrumentation • Industrial Automation • Entrepreneurship • Robotics
• Technology in Automation

ADVANCED DIPLOMA IN MACHINE MAINTENANCE & AUTOMATION (ADMMA) (Approved by NSQF Level-6)

Duration : 6 Months **Course Fee** : Rs.44,500/-
Eligibility : Diploma in Electrical / Instrumentation Engineering and
Equivalent

COURSE CONTENT : **Module 1** :- Operation / Maintenance of Conventional
Lathe, Milling, Grinding, CNC Milling & CNC Lathe. **Module 2** :- Basic
Electrical Control and Electric Drives. **Module 3** :- Industrial Automation: PLC
Programming and SCADA Operation • Basic PLC, PLC Hardware details,
• Ladder Programming for HVAC Electrical Ladder Schematics,
Module 4 :- Hydraulics & Pneumatics, • Supervisory Control & Data
Acquisition (SCADA) Verification, SCADA with HVAC Electrical equipments.
Module 5 :- Basic Electronic Components and its application.

MASTER CERTIFICATE COURSE IN AUTOMATION & PROCESS CONTROL (MCCAPC) (Approved by NSQF Level-7)

Duration : 6 Months **Course Fees** : Rs.43,000/-
Eligibility : Degree in Electrical/Electronics/Instrumentation Engg. and
Equivalent

COURSE CONTENT : **Module 1** :- Drive control and applications: • Advance
electricity and industrial devices, wirings and implementation • AC & DC
machines routine test • Sensing and transducers technology.
Module 2 :- PLC : • Advance PLC and interfacing with block applications
• LAD, FBD and STL programming basics • FB, FC, DB block programmings.
Module 3 :- SCADA : • Introduction to basic SCADA application. Application of
TAG-management • Details of graphic designer, editor • Details of alarm
logging. • Online trend control documentation. **Module 4** :- Embedded
Systems • Interfacing & testing using ARM Micro controller.
Module 5 :- Hydraulics & Pneumatics • Pneumatic circuits and
implementation. • Hydraulic circuits and implementation. • Interfacing with
PLC and automation control. **Module 6** :- Process control systems : • DCS
programming and application • PID / PD / PI / P - Application • AUTO-CAD
electrical drawing applications • PROJECT WORK.

ADVANCED EMBEDDED TECHNOLOGY (AET) (Approved by NSQF Level - 6)

Duration : 6 Months **Course Fees** : Rs.44,500/-
Eligibility : Diploma / Degree in Electrical / Electronics / Computer /
Bio- Medical / IT / Instrumentation. B. Sc. / M.Sc. in (IT /
Electronics / Physics) and Equivalent

COURSE CONTENT : Introduction to Embedded Systems and Fundamentals;
VLSI , C & C++, PIC Micro Controller, Interfacing with Communication
Peripherals, ARM, RTOS, Robotics, PCB, Python on Raspberry PI.

Selection Procedure : First come first serve basis

CISCO CERTIFIED NETWORK ASSOCIATE (CCNA) – (Approved by NSQF Level - 6)

Duration : 04 Months **Course Fee** : Rs. 25,000/-
Eligibility : 12th/Graduation/Diploma/Degree/BCA & MCA (Pass out)
and Equivalent

COURSE CONTENT : IP Addressing, VLSM, Windows Networking, IPV6,
Protocols, Switching, Routing, DHCP, VTP, EIGRP, OSPF, Authentication,
VPN, ACLs, Frame Relay, NAT, IoT, RIPV2, HSRP, BGP, Wireless Networking,
ML Switches, Project Work.

The course contains 80% practical work with software's and real CISCO
devices.

ADVANCE DIPLOMA IN COMPUTER HARDWARE & NETWORK MANAGEMENT (ADCHNM) – (Approved by NSQF Level - 6)

Duration : 06 Months **Course Fee** : Rs. 44,500/-
Eligibility : B.Sc / BCA / MCA / Diploma / Degree in any
Discipline (Pass out)

COURSE CONTENT : Basic Electronics and project, SMPS & ckt.repairing,
Mother Board & repairing, PC Architecture, Monitors, Printers,
OS, SIUM, Office Package, Laptop overview, Assembling, Basic Networking,
LAN setup & Up gradation, Server Applications, ADDS, DNS, WDS, FTP,
Wireless Networking, N-Computing, Linux server Management,
Troubleshooting.

MASTER CERTIFICATE COURSE IN MECHATRONICS (MCCM) (Approved by NSQF Level-6)

Duration : 6 Months **Course Fees** : Rs.44,500/-
Eligibility : Degree/Diploma In Mechanical Engineering Or Equivalent

COURSE CONTENT : Basic Automation Techniques, PLC Programming,
SCADA, Auto CAD ,Sensor and Actuators, Industrial Hydraulics &
Pneumatics, Mechatronics Technology & Kits

Note : • Only the registration fees can be paid by SC/ST Candidates Rs.1200/- Subject to production of two copies caste certificate duly self attested & Aadhar Card . • All below eligibility candidates can also apply through **RPL Test** for the above courses except CCNA Course.Registration can be done through Demand draft of Rs 1200/- drawn in favour of "Central Tool Room & Training Centre" Payable at Kolkata.

Contact Person: M Ramarao - 9038578065

MSME SAMPARK : SKILLS UNBOUND, OPPORTUNITIES UNLIMITED

For further details visit our Website: www.msmetoolroomkolkata.com

EPLAN

efficient engineering.

► Evolution in Engineering

Contact EPLAN to know why Volkswagen, Audi, Mercedes, General Motors and their suppliers have EPLAN Software as standardization tool since 2002.



For More information:

Login: www.eplan.in

Write to: info@eplan.in

Contact: Sindhu Krishnappa

+91 98865 50509

PUBLISHER'S NOTE



V ANBU
DIRECTOR GENERAL & CEO
IMTMA

Dear MMI Readers,

As one of the fastest growing economies in the world, India is one of the few bright spots in the world economy. The country which aspires to become a \$5 trillion economy by the year 2024-25 with manufacturing sector alone contributing \$1 trillion is expected to overhaul its manufacturing infrastructure. The auto industry, one of the major consumers of machine tools, is facing headwinds but we expect it to bounce back in the near future. Espousing technologies and solutions across the entire spectrum of industries along with optimized resource utilization will enable manufacturers to tide over the numerous challenges confronting them. The machine tool industry perhaps needs to explore more avenues such as defence and aerospace and make an impact there.

Modern Manufacturing India (MMI) magazine published by Indian Machine Tool Manufacturers' Association (IMTMA) in this edition brings you a collection of articles on aerospace manufacturing which will give you an insight into the developments taking place in the aerospace sector. There is also an opinion piece by IMTMA on survival strategies in economic downturn and a special article on strengthening the small and medium enterprises for transforming India.

Readers, as we share thought-provoking articles and reports on various industries, we also reach out to you for your feedback, comments and analysis to make this magazine more insightful and interesting. The exercise helps us to understand your requirements and allows us to meet your expectations as we move ahead. I thank you once again for your continued interest in the activities of our Association.

Readers can download previous issues of MMI from the IMTMA website www.imtma.in

High value-added production on easy-to-use machines



Intelligent Multitasking Machines **MULTUS BII series**

MULTUS B200II / MULTUS B250II / MULTUS B300II / MULTUS B400II

- 1** Process-intensive machining of complex shaped workpieces
- 2** Powerful, compact turret and large work envelope
- 3** Spec extensions to handle all kinds of workpieces
- 4** High accuracy gear machining with a multitasking machine
- 5** Array of Intelligent Technology supports operators



See the demo
video on the Web.



OPEN POSSIBILITIES

Okuma India Pvt Ltd

Plot-89, Phase 2, Udyog Vihar, Gurgaon, Haryana, India
TEL: +91-12-4425-0229

www.okumaindia.com

OKUMA



Soumi Mitra

SOUMI MITRA
Editor-in-Chief
Modern Manufacturing India
soumi.mitra@magicwandmedia.in

SINCE SPRING ALWAYS FOLLOWS WINTER

India, this year, had many reasons to celebrate its National Sports Day, which it did with much fervor and gaiety. Ace Indian shuttler P V Sindhu redefined our country's sports history by becoming the first Indian to win a gold at Badminton World Federation (BWF) World Championships.

On the same day, Manasi Joshi made India proud by becoming the first Indian Para-Badminton World Champion, clinching her maiden Gold medal in BWF.

Similarly, ace Indian sprinter Dutee Chand created history by winning a gold medal in the 100m event at the World University Games recently, becoming a second Indian sprinter to win a gold in an international event after Hima Das, who finished on top in 400m at the World Junior Athletics Championships last year.

The common denominator in the above examples is the tenacity, dedication and perseverance to go after the things that one truly wants. No road to success is devoid of obstacles and setbacks. But one must constantly remind oneself that anything worth accomplishing is tough and failures are meant for a reason. For Joshi, a lost leg was never an excuse and her victory must be a tale of a multitude of failures.

Our manufacturing sector, in the pursuit of its goal to be a global manufacturing powerhouse, should not let temporary headwinds waver it. We have come this far and have been raising our bar in the field. Let's continue in the same spirit as our sports heroes' and get in the flow, remaining undaunted in the face of any adversity on the way. A dark cloud too has a silver lining and the sun still shines bright behind it. It is for us to remain persistent in our efforts and wait for the sun to come forth and spread the light again.

Team MMI, in this issue, has yet again compiled stories that reflect our industry's grit and gumption and inspire us to remain undeterred come what may. Do write to us what you feel about them.

*"Never give up.
Today is hard, tomorrow
will be worse, but the day after
tomorrow will be sunshine."*

- Jack Ma

Chennai Metco

www.chennaimetco.com



myDMG MORI
CUSTOMER PORTAL

YOUR HISTORY

YOUR MACHINES

YOUR DOCUMENTS

YOUR SERVICE REQUESTS

45 HIGH-TECH
MACHINES

29 AUTOMATION
SOLUTIONS

>30 DIGITAL
INNOVATIONS

CONNECTIVITY
COMPLETED

ADDITIVE
MANUFACTURING



SURVIVAL STRATEGIES IN ECONOMIC DOWNTURN

Economic downturns give one an opportunity to introspect, rethink about ongoing activities, cut costs, increase cash flows, enhance technological capability, and reorient market strategies. They present a chance to explore ways to improve and form new goals to re-emerge as a strong contender.

In the early 2000, when public at large were getting familiar with online marketing, a relatively young Amazon sold \$672 million in convertible bonds to overseas investors. The stars were aligned for the e-commerce company as it raised money on the eve of the big dotcom crash which caught many in the business off-guard and pushed them out of business altogether.

Economic downturns or even full-blown recessions hit every industry at some point of time. There are cases where companies perform well in wartime but suffer when it is peace. Recessions occur over a span of time, sometimes for a short stretch, and, at times, over a longer time-frame. So how can an industry flourish in the adversity of an economic downturn and do well when others in the fray struggle to make their ends meet.

Causes for downturn

Sudden spike in oil prices, financial panics (like the one we witnessed before the great recession), animal spirits (quick changes in economic expectations like the one we saw in the dotcom burst) are factors for recession. Firms are hit due to the lack of demand, loss of revenue and uncertainty about future. Investors get nervous when they notice consumer sentiments falling and begin to sell their shares. Research, however, has shown that this may not bode well over the long run and companies need to find alternatives to survive and flourish by not pressing the panic button and keeping an eye on profits in the long run.

Risks to the economy

Often, economic forecasting is an inaccurate science, as one set of analysts may say that the worst may be over, while others may predict a more serious recession in the near term. This uncertainty happens due

to technological risks such as cyber security, data privacy, artificial intelligence governance, economic policy risks, challenges to international institutions, social inequalities, planetary risks such as climate change, and so on. Primarily, technological changes, global competition, and policy changes remain as the triggers for the impact.

Preparing for the next downturn

The manufacturing industry needs to best position itself in the eventuality of such harsher macroeconomic conditions. Slowdown, no doubt, brings challenges with it, but also opens up opportunities which could benefit the industry during and after the downturn. Preparing too little and too late will hamper business prospects. When economic headwinds are a possibility, it is advisable to act early to pre-empt any inevitable losses besides learning the right lessons from the past.

Business heads need to look deep at the long-term perspectives during a downturn to stay abreast of insolvency. To survive as well as gain sustainable advantage, companies need a balanced approach to performance. They need to pursue efficiencies for improving their profit margins apart from solely focusing on cost reduction. Focus on revenue growth accounts for a big chunk of the shareholder return, perhaps more than

Source: Magic Wand Media



the double of what one would get from cost reductions.

Investing in R&D

Sustained growth is difficult to achieve year-on-year unless companies invest in R&D and innovations to stem the tide. Those who invest time, effort and money will have the best chance to grow further over a long term. It is only during a downturn that companies critically examine the health of their business and focus on their inherent vulnerabilities, which otherwise get overlooked when all is well. This helps drive the large-scale change which is needed for success in future. Technology is reshaping all industries and leading to fragility in the marketplace. Downturns amplify competitive volatility that can be countered with the right technology and, therefore, companies shouldn't put a stop to technological progress during recession. The push towards digital technology is widely seen as an attempt to build firmer relationships which can help survive the next economic crash. Economic downturns give us an opportunity to rethink about our ongoing activities, look at ways to improve and form new goals to re-emerge as a strong contender. It is another chance to look inward, introspect, cut costs, look for means to increase the cash flow, rethink on setting new goals and conquer new domains, enhance technological capability, reorient our market strategy, and so on. Finally, a company's performance in times of recession and afterward depends on the decisions it makes, who makes it, and how best it is handled to weather the shocks. The next downturn may be around the corner but only those who plan thoroughly will emerge stronger and stay competitive in the market. 

A company's performance in times of recession and afterward depends on the decisions it makes, who makes it, and how best it is handled to weather the shocks. The next downturn may be around the corner but only those who plan thoroughly will emerge stronger and stay competitive in the market.

WORLD OF HONING..

Baby Elephant

HIGH ON PRECISION

HIGHER ON PRODUCTIVITY

Single Pass Honing Machine SP425



Bore accuracy 2 micron
5000 parts a day
High L/D ratio
Less foot print
Less skilled operator required



EMO
Hannover
16-21.9.2019
Stand A42
Hall 11

 **Khushbu**
Honing

www.khushbuindia.com

F24/1, M.I.D.C. Shirol, Kolhapur-416122. Maharashtra, (IND.)

P: +91-230-2468859. E: honing@khushbuindia.com

M: +91 9371658016, +91 8149714625



STRENGTHENING SMEs FOR A NEW INDIA

The Small and Medium Enterprises (SME) sector has a crucial role to play in the country's industrial development. Waking up to the fact that not enough has been done towards its upliftment, the Government has taken certain initiatives that have the potential to raise the sector's bar and empower it to meet global needs.

For the large number of SMEs that dot India's landscape the business may perhaps be demonstrably smaller than the industries that rely on it. It is the role played by SMEs that make them critical for the manufacturing industry's success. SMEs are considered as the backbone of the industrial development owing their big share and remarkable contribution in it, total manufactured exports and the extent to which they have generated employment.

Surmounting challenges

SMEs have a strong presence but face numerous challenges that hinder their growth. Continuous quality improvement, scope and scale are primary trials to be overcome. Sustainable development of manufacturing will happen only when SMEs upgrade the technologies which they deploy for shop-floor activities and enhance the skill-set of workers tending their machines. This will reduce the extensive manual interventions in the processes and enable a smooth flow of data.

Digitalization is slated to help SMEs enhance their efficiency to scale up, overcome manufacturing defects, reduce production cost and shorten production lifecycle. The future will see them meeting global quality standards and strengthening their position as proficient suppliers. The automotive industry is a befitting example

where entrepreneurs have used modern technologies in their production process. Catering to the demands of the automotive industry kept them firmly on their feet in terms of R&D, innovation and investments, and we today see them as primary suppliers for many auto companies.

Metal forming and metal cutting exhibitions such as IMTEX provide a large platform for manufacturing industry to sharpen their everyday activities with advanced technologies and create extraordinary competitive advantage as well as sell machine tools to a global market. Companies which have fully understood the power of digitalization and are utilizing it for their business are leading a new wave of growth.

Ensuring SMEs' progress

The announcements spelled out in the Union Budget 2019 are widely seen as favorable for SMEs. The 25 percent cut in the corporate tax for companies with annual turnover of up to ₹400 crore is expected to boost

investments. It is a positive step towards the development of the SME sector and enhancing their production capacities. The machine tool industry is the mainstay of SMEs and this move bodes well especially for machine tool manufacturers. The Indian machine tool industry has around 1,000 units engaged in the production of machine tools, accessories / attachments, subsystems and parts. More than 90 percent of these are in the SME sector which are likely to benefit from this budget. The ministry's move is expected to eventually give an uptick to machine tool industry's business. Moving forward the Government of India may implement suitable measures to extend credit to SMEs along with connected financial reforms. With India targeting to become a \$5 trillion economy by 2024-25 and manufacturing sector contributing \$1 trillion to it, SMEs have a large role to play. 

The 25 percent cut in the corporate tax for companies with annual turnover of up to ₹400 crore is expected to boost investments. It is a positive step towards the development of the SME sector and enhancing their production capacities.



Compact Solution for Coolant & Chip Management

NOP CYCLONE FILTER PUMP

- Supply Filtered coolant to Machines for Niagara, Bed Flushing, Wall Flushing, Fixture Cleaning, Hand-Gun and High Pressure Coolant Tank
- Ensures more productive time on your machines
- A must for Automated Manufacturing and IOT environment
- Avoid damage to surface of work piece & Seat-check alarm
- High capacity filtering cyclone system can automatically clean the tank and substantially cut down coolant tank maintenance Time
- Clear the pipe clogging by filtering contaminant with cyclone
- Easy to retrofit as cyclone filter and pump are compactly combined in one & minimize Energy consumption

Suction Strainer	3mm (Solids larger than this must be removed from the tank)
Cyclone Filter	Water-soluble coolant fluid 100 μm: 99.9% (Silica sand Specific weight 2.7) Straight oil 100 μm: 80% (Silica sand Specific weight 2.7)



TOP -YTH①② -③CG

Motor capacity	1500: 1.5 kW
Motortype	R1: 415 V· 50 Hz R2: 230 V· 60 Hz R3: 200 V· 50/60 Hz R4: 400 V· 50 Hz R5: 380 V· 50 Hz R6: 440 V· 60 Hz 3 phase electric induction motor (IE3) with CE marking *Please contact us for other standard

③ Flow rate	50 Hz	I135CG: Impeller pump (5 stages / 135 LPM)
	60 Hz	I132CG: Impeller pump (2 stages / 135 LPM)
Filtering method	C : Cyclone type	

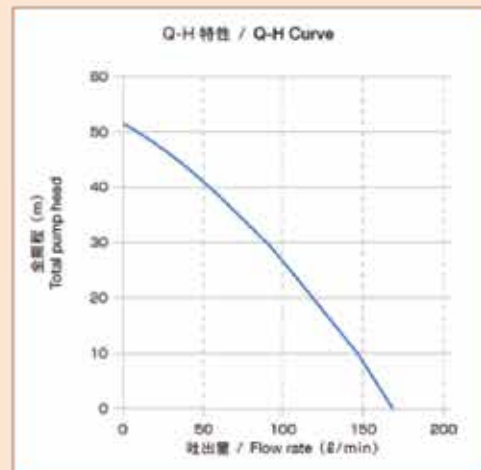

Scan the QR code for more technical details: →



Tel: +91-80-4365-900
e-mail: coolantpump@rajamane.com
Tel: +91-124-405-6644
e-mail: info@nopindia.com

FM Proffers Hope to Auto Sector

New Delhi, India - The Union Finance Minister Nirmala Sitharaman recently announced a slew of measures, including ones to empower the auto sector, to revive economic growth. The Indian automobile sector contributes 7.5 percent to the country's GDP. However, the industry is facing major headwinds both at the global and domestic level.



Source: Magic Wand Media

The Finance Minister dispelled confusion regarding the switch to BS VI emission standards. All BS IV vehicles purchased up to March 2020 are to remain operational for the entire period of registration. Additionally, the proposed increase in the one-time registration fees for the new vehicles has been deferred until June 2020. To help boost demand, along with 15 percent depreciation an additional 15 percent depreciation on all vehicles has been announced until March 2020. The Government's focus, she assured, will be on setting up the infrastructure for the development of ancillaries and components including batteries for export. Public Sector Banks (PSBs) will get an upfront funding of ₹70,000 crore through recapitalization, which will bring in more liquidity.

Blaser at EMO 2019

Hannover, Germany - Blaser Swisslube is to showcase its metalworking fluid solutions at EMO 2019. Brand ambassador Titan Gilroy of 'TITANS of CNC: Academy' will personally be at the Blaser booth (Hall 6 / Stand J60). Showcased products include Synergy 735, a crystal-clear, water-miscible and oil-free fluid; high-performance grinding oil Blasogrind GTC 7 suitable for tool grinding as well as for profile and creep feed grinding; and B-Cool MC 610, a water-miscible coolant ideal for general machining with a significant share of copper-base alloys.



Source: Hannover Messe

LMW and Boeing India to Train in Aerospace Tools

Chennai, India - Boeing India Pvt Ltd has joined forces with Coimbatore-based Lakshmi Machine Works (LMW) to launch Aerospace Tool Design and Manufacturing Program and impart students the technical know-how and skills needed in the aerospace tool manufacturing sector. LMW is into manufacturing parts for the aerospace industry. The first batch of 32 trainees will undergo a 12-month program comprising six months of classroom training at GKD Institute for Technological Resources (GKDITR) followed by on-the-job training at LMW Advanced Technology Centre. The program curriculum is designed by Learning Links Foundation and includes classroom sessions, hands-on training, and sessions from industry experts. "The program is aimed at providing quality technical education and developing skilled manpower. We will continue to support such programs to ensure



Source: LMW

that our skilled workforce is able to deliver high-quality products for the aerospace industry in the country and the region," said Sanjay Jayavarthanavelu, Chairman & MD, LMW.

Siemens' Indigenous Innovation for IR

Mumbai, India - Siemens is equipping Indian Railways' (IR) 9000HP electric locomotive with the first indigenously-designed and produced integrated propulsion system and steel tank transformer. Indian Railways is upgrading its electric locomotives from 6000HP to 9000HP as part of its rail electrification initiative. The company is supplying high-power traction converters, motors, drive systems and steel tank transformer, which will be part of the propulsion equipment for 9000HP freight and passenger locomotives. These locomotives will boost the haulage capacity of Indian Railways by around 50 percent, thereby improving average speed and utilization of rolling stock assets. The advanced technology aims to save traction energy cost, reducing fuel expenses and carbon emissions. Chittaranjan Locomotive Works (CLW) has pre-commissioned this indigenous 9,000HP electric locomotive and trial runs will commence soon.



Source: Magic Wand Media

Theme that Shows the Way Forward

Hannover, Germany - Hannover Messe 2020 will spotlight all the latest trends and topics, such as Industry 4.0, artificial intelligence, 5G and smart logistics. The display categories to be featured are 'Future Hub', 'Automation, Motion & Drives', 'Digital Ecosystems', 'Energy Solutions', 'Logistics', and 'Engineered Parts & Solutions'. The program will be rounded off by more than 80 conferences and forums. It will be staged from April 20 - 24, 2020 in Hannover, Germany, with Indonesia as its official Partner Country. Sporting its 2020-season lead theme of 'Industrial Transformation' and featuring some 6,000 exhibitors, the world's top trade show for industrial technology will shine a light on the opportunities arising from new technologies, changing buyer behavior and a growing awareness of climate protection. "The world is embarking on a period of change, the likes of which we haven't seen for a long time," said Dr Jochen Köckler, Managing Board Chairman, Deutsche Messe. "And that makes Hannover Messe more important than ever - because it is the only trade show

to accord the industrial transformation process the holistic and ongoing focus that it warrants. Thanks to the diversity and expertise of its multi-industry exhibitor base and its lead-theme focus on Industrial Transformation, Hannover Messe is a trend barometer and innovations driver for a globally and digitally integrated industrial sector."

High Feed Finish Milling Cutter for Aluminum Alloys

FMAX

Feed Maximum (FMAX) milling cutter for ultra efficient and accurate finishing.

- Ultra High Efficiency Machining
- High Precision, Easy Setting
- Designed for High Speeds
- Light Weight, High Rigidity Body
- Economy, Multi-use

New PCD Grade for Machining Aluminum Alloys



THE ULTRA FINE
PITCH DESIGN
IS IDEAL FOR
HIGH EFFICIENCY
MACHINING

($vf \geq 20000$ mm/min)



MMC Hardmetal India Pvt. Ltd.
A Subsidiary of MITSUBISHI MATERIALS

Tel : +91 80 2204 3600 - 2204 3699
Website : www.mitsubishicarbide.com
Email : mmcindia@mmc.co.jp

YOUR GLOBAL CRAFTSMAN STUDIO

Dynascan Inspection Systems Company

Position: Service Engineer **Location:** Pune

Key Requirements:

- The role demands one to be responsible to provide technical support and expertise to customers;
- Handle testing applications, responding to customer feedback and maintenance, and performing demonstrations;
- Take care of installation and training of the product line and managing their maintenance periodically once the installation is completed;
- Should be hardworking, dedicated, and adaptable.



Dynascan Inspection Systems Company

No. 39-P/1 Phase 2 East, Electronic City, Hosur Road, Bengaluru 560100, Karnataka
T: 9743411700 | E: sachin@dynascan.info | www.dynascan.com

Hexagon Production Software

Position: Customer Sales Representative **Location:** Pune

Key Requirements:

- The candidate should be a graduate in any discipline;
- 3 to 5 years of experience preferably in CAD/CAM/CAE domain;
- Good knowledge of CRM Tools such as Sales Force and MS Office;
- Good written and verbal communication skills;
- Roles involve: researching and sourcing potential business opportunities and contacts through web research and other alternatives;
- Identifying prospects by cold calling;
- Positioning the product from sales perspective and convincing the suspects / prospects by providing correct information regarding products, services, and benefits through telecalling;
- Qualifying the generated leads along with the appointment data and passing to respective sales representative;
- Analyzing sales trends and competitive information;
- Sending proposals, quotations to customers and prospects.



Hexagon Manufacturing Intelligence

A-9 Sector-65, Noida 201301, Uttar Pradesh | T: +91 120 472 3000
E: ranjeet.ghorpade@hexagon.com | www.hexagonmi.com

HYDAX Hydraulics Pvt Ltd

Position: Sales Executives **Location:** Attibele, Bengaluru

Key Requirements:

- The candidate should preferably be a BE or an engineering diploma holder;
- Should have experience in marketing;
- Must be well-organized, polite, and pleasant conversationalist with good command over English and spoken Hindi;
- Must have above average English writing skills;
- Maintain relationship with existing customers by a continuous follow-up.



HYDAX Hydraulics Pvt Ltd

Plot no. 22-B, Attibele Industrial Area, Anekal Taluk, Bangalore 562107, Karnataka
T: 9731274120 | E: meetali@hydaxindia.com | www.hydaxindia.com

Marshall Machines Ltd

Position: Deputy Manager / Manager / Assistant Manager / Sr. Engineer / Engineer

Location: Bangalore / Chennai / Ahmedabad / Rajkot

Key Requirements:

- The candidate should be BTech / BE (Mechanical) having 3-8 years of experience in Sales & Marketing relevant to our industry;
- He should be responsible for developing business and establish brand image in the market;
- Must focus on Customer Relationship Management;
- Should be able to think strategically and lead diverse teams to achieve stretch targets;
- Must have good communication skills and the ability to build trust and rapport for strong business relationships;
- Local candidates are preferred.



Marshall Machines Ltd

C 86, Phase-V, Focal Point, Ludhiana 141010, Punjab
T: +91 161 5012 5406 / 5012407 | E: rupinder.hr@marshallcnc.com, hr@marshallcnc.com
www.marshallcnc.com, www.marshallautomationamerica.com



On the go. Always arrive

With CNC machining centres and turnkey solutions from CHIRON, STAMA and SCHERER. With everything that the automotive industry needs: highest precision, maximum availability and minimum costs per piece.

CHIRON Group

chiron

STAMA

SCHERER
FEINBAU

cms

**CHIRON India Machine
Tools Private Limited**
Bangalore, India
Tel +91 80 4905 6490
info@chiron-india.com

www.chiron-group.com

SOARING TO NEW HEIGHTS

Along with the soaring demand for civil aircraft from Asia, there has also been a significant rise in aircraft component manufacturing in the continent. Several Japanese companies are adept at the job and can prove to be competent partners for other Asian players.



Source: Mitsubishi Aircraft Corporation

Kensuke SAITO
Director
Aircraft Component
and Material
Industries Office
Manufacturing Bureau
Ministry of Economy,
Trade and Industry
(METI)
saito-kensuke@
meti.go.jp



The civil aircraft market is expected to grow double to approximately 40,000 aircraft in the coming two decades, and 40 percent of the demand is considered to originate in the Asia-Pacific region. Alongside the increasing demand for civil aircraft, manufacturing aircraft components in Asia is also on the rise. However, many aircraft components manufacturers have reported their difficulty in finding qualified suppliers in Asia.

Japanese companies could be of help here, especially in transforming Asian manufacturers into aircraft component manufacturers. In April 2019, a joint venture for manufacturing aerospace equipment was established in Malaysia by Sapura Industrial Bhd, a major Malaysian auto parts manufacturer with Wada Aircraft Technology Co., Ltd and its subsidiary, Aero Inc. that has a track record in designing and assembling aircraft parts and fixtures in Japan. In the next five years, it will invest about

\$24 million to construct a plant to manufacture aircraft parts in the Kuala Lumpur metropolitan area. The joint venture plans to fully manufacture and assemble aircraft parts from 2021. Imai Aero-Equipment Mfg. Co., Ltd (IAC), a long-time partner with Japanese heavy industries for the aerospace industry, has manufacturing bases in Malaysia, Thailand and Vietnam. The Malaysian factory is equipped with 5-axis machining centers and surface treatment plant. The tank size is one of the

INDIA'S FINEST RANGE OF CNC MACHINES



New Launches 2019



JV 65
Vertical Machining Centre



JV 105
Vertical Machining Centre



JV 130
Vertical Machining Centre



JV 200
Vertical Machining Centre



JU 60
5 Axis Machining Centre



LTV 50M
Vertical Lathe with Live Tools



JHM 40
Horizontal Machining Centre

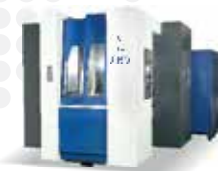

JH 50
Horizontal Machining Centre



JH 63
Horizontal Machining Centre

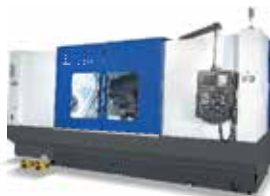

LR30T L12
Horizontal Lathe

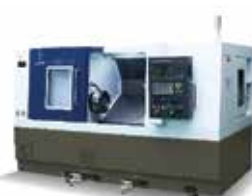

LL30T L7
Horizontal Lathe



SmartXprs
Horizontal Lathe with integrated Automation

For Enquiries
Mr. Pankaj Jha | Sr. Manager - Marketing
Phone: +91 73977 70016 | E-mail: pankaj.jha@lmw.co.in

Global Sales:
Mr. Arun Kumar S | Asst. Manager - Exports
Phone: +91 95435 43515 | E-mail: arunkumar.s@lmw.co.in

Follow us on



LAKSHMI MACHINE WORKS LIMITED
Machine Tool Division,
Arasur, Coimbatore – 641 407, Tamil Nadu, India.
Phone : +91 422 719 1393 to 1397

biggest around South East Asia. The company is an important supplier for Spirit AeroSystems Malaysia Sdn Bhd.

Mitsubishi Heavy Industries has been producing parts for Boeing 737 and 777 in Vietnam and Jamco has been making composite material and interior components in the Philippines. Thanks to the Automobile industry in Asia, there are thousands of Japanese manufacturers all over the continent. They can be important bases for expanding the Aircraft supply chain in Asia.

Since governments in many Asian countries have been working on the vitalization of the Aircraft industry, 'Asia Aircraft Supply Chain Forum' was held in November 2018. Major aircraft companies such as Boeing, Safran and Collins Aerospace, and Asian manufacturers met together in Tokyo. In addition, the Ministry of Industry, Thailand and The Malaysian Investment Development Authority (MIDA), Malaysia, presented their strategies to promote the industry. Over 350 officials and experts from international companies participated.

Japanese experience in aircraft industry

Japan's aircraft industry is expected to be \$18 billion in 2020 and about \$27 billion in 2030. Over the past 40 years, the industry has been developed through participation in international projects with



Many panelists highlighted the need for Japanese technologies and partnerships in Asia during the 'Asia Aircraft Supply Chain Forum'.

Boeing and engine OEM manufacturers. Now, Japanese companies are responsible for 35 percent of the airframe of the B787 and 23 percent of the PW1100G-JM engine, which is on the A320neo. In January 2019, the Ministry of Economy, Trade and Industry (METI) and Boeing signed an agreement to deepen cooperation in future technology in areas such as electric technology, including advanced lightweight batteries, advanced motors and controllers necessary for electric propulsion systems in aircraft; high-rate, low-cost composite production technologies; and automation technologies to improve manufacturing productivity.

Japan is also working with Airbus. METI and DGAC (French aviation authority) established the Japan-Airbus Ad Hoc Civil Aeronautical Industry Working Group in March 2017, introducing new technology from even outside the aviation industry in Japan. Hence, many Japanese

companies had to participate in the Airbus training.

METI has also supported basic research and development of materials for aircraft such as Ceramic Matrix Composites (CMC) for further heat and pressure resistance. These experiences have led to the development of Mitsubishi Regional Jet (MRJ), Japan's first jet airliner with 70-90 seat capacity. Mitsubishi Aircraft Corporation targets the first delivery of MRJ in mid-2020 to All Nippon Airways.

Japan's aircraft SME networking

Not only large companies, but Japanese manufacturing SMEs are also increasingly interested in the aircraft industry. There are more than 40 aircraft manufacturing clusters in the country, which are listed on the website of 'The Nationwide Network of Aircraft Manufacturing Clusters' (NAMAC). Most of them have secured the certification of JISQ9100, which is equivalent to AS9100, a quality management standard. Aircraft manufacturing requires certified NDT (Non-destructive Testing) professionals and it is not easy for SMEs to secure those professionals. In this regard, Japan National Aerospace Non-Destructive Testing Board (NANDTB-Japan) was set up in 2017 to certify NDT professionals of NAS 410 for SMEs in Japan. The first examination will be held by the end of this year. 

The civil aircraft market is expected to grow double to approximately 40,000 aircraft in the coming two decades, and 40 percent of the demand is considered to originate in the Asia-Pacific region.



Imai Aero-Equipment Mfg. Co., Ltd (IAC) has manufacturing bases in Malaysia, Thailand and Vietnam, and is an important supplier for Spirit AeroSystems Malaysia Sdn Bhd.

Switch to Bechem Avantin. Switch to Peace of Mind!



Coolants that will make you forget emulsion problems

Emulsion issues of foul smell, froth, corrosion, dirty machines, frequent changes are Production Manager's nightmare. With little control over the vulnerable water that forms 95% of the emulsion, you require a resilient coolant that can form a stable emulsion over time.

BECHEM's Avantin range is a one-stop solution for all your machining problems with coolant. With German lineage and industry experience of over 180 years, Avantin range is based on advanced formulations that are designed to deliver superior machining performance consistently.

• Coolants & Cutting Oils • Industrial Cleaners • Forming Fluids • Speciality Greases & Oils

CARL BECHEM LUBRICANTS (INDIA) PVT. LTD.

#28 D, Bidadi Industrial Area, Bangalore 562109

Ph: +91 80 66900800

mail: sales@bechemindia.com | www.bechemindia.com



BECHEM
LUBRICATION
TECHNOLOGY



WHY TRADE SHOWS MUST GO ON

From visibility to striking new deals, exhibitions and trade shows offer opportunities no business would want to miss out on. It is a strategy that has withstood the test of time, playing a significant role in the success of most machine tool companies.

A preferred medium

Trade shows offer factors such as easy access to enthusiastic prospects open to research and deal, direct communication, real-time feedback and regional to global exposure that act beneficial in expanding one's customer base.

It is simply a profitable choice of medium since no other has such potential to physically get you prospects; none can harness all company's assets or help set and achieve multidisciplinary goals namely marketing, sales, relationship management or get you to know the market and your standing, vis-à-vis your competition, at one go.

Barometer point

Given the strategic importance of exhibitions as an export building platform, it is important that they are used well and measured against the set goals for participation. Companies get better convinced about participation in shows if they measure their exhibition results and compare them with the other promotional methods. To make informed decisions, it is easy to see why measuring exhibitions is not only important, but also highly essential:

For investment justification: No two shows are alike. Hence, it is important to choose the best exhibition. Measurements help in identifying winner shows.

To improve activities: What you do before, during and after each exhibition matters as much or more than the exhibition itself. Measurements improve team's performance and results.

Encourage goal-driven activities: What gets measured gets done. If you want your team focused on results, tell them what results mean to you and show them you are measuring.

Seeking quantifiable goals

Measuring success in exhibitions is not just about counting the collected visiting cards or the visitors registered at the stall. The best goals are the ones that can be quantified as quantifiable goals motivate and drive action. For example, instead of the goal to get media coverage, it must be to get five articles or product reviews printed in the show daily. You will then realize that it is much easier to measure your performance against a hazy goal when stated in a measurable way.

Setting goals when participating in exhibitions is the most important element of the measurement system. The best goals are the quantifiable ones since they drive action.

T K RAMESH
Managing Director and CEO
Micromatic Machine Tools Pvt Ltd

The views expressed by the author are personal and he can be contacted at rameshtkr@gmail.com

HYDAX[®]
HYDRAULICS MACHINES ROBOTS



- Flexible Drive Coupling
- Fluid Level Gauge
- Suction Strainer
- Filler Breather Assembly
- Threaded Breather
- Return Line Filter
- Pilot Check Valve
- Gauge Isolator Valve
- Pressure Line Filter
- In-Line Filter
- Spin-On Filter
- Electrochemical Deburring Machine
- Coolant Filtration Machine
- Hydraulic Power Pack



HYDAX Hydraulics Pvt. Ltd.

22B, Attibele Indl. Area, Anekal Taluk, Bangalore - 562107, Karnataka
E: info@hydaxindia.com | T: +91-9916070034 / +91-9513499976
www.hydaxindia.com

**FIBRO**

The worldwide pioneer in Rotary Tables for
Machine Tools & Automation systems



Standard Parts
for Die & Mould Making



**FIBRO India Association
With HEMA, Germany for**

- Protection Systems
- Viewing Systems
- Clamping and braking systems

required by Machine tool OEMs

NEW

CLEARING THE AIR



Source: Magix, Wand Media

Source: Team MMI

As the Indian Auto Industry moves towards the more stringent BS VI emission norms, it is crucial to have a clarity over what prompted the move to happen and how the industry is preparing for it. Industry experts help explain its effect across various segments of the Indian Auto and Machine Tool Industries and their own contribution towards this massive change...

Pollution Stops Play' screamed headlines across the world on December 3, 2017, when a cricket Test match between Sri Lanka and India in Delhi was interrupted due to air pollution. The levels measured were 15 times more than the WHO limits. This was the first recorded instance of an international match being called off due to pollution that brought worldwide attention to India's endemic pollution problem.

Vehicular emission is a major contributor to the worsening air quality of Indian cities and 22 of the 30 most polluted cities in the world are in India. In cities like Delhi, the levels of cancer-causing particulate matter in the air is 6 times more than the prescribed levels by WHO.

Government initiatives

In October 2016, India signed the Paris Climate Agreement, which obliges it to bring down its carbon footprint by 33-55 percent from the levels recorded in 2005 over 12 years. This warranted the need for a stricter norm that could reduce the emissions considerably and put India on track to meet the Paris agreement goals.

In normal circumstances, BS V would have been rolled out by 2021 and BS VI in 2024, but in 2016, the Government decided to take strong measures and announced that India would leapfrog directly from BS IV to BS VI emission norms by March 31, 2020. When implemented, this would be the fastest transition from BS IV to BS VI anywhere in the world.

All about BS VI

BS VI is equivalent to Euro VI, which is the norm for emissions across Europe. The major difference between BS IV and forthcoming BS VI norms is the



Source: Ashok Leyland

"OEMs cannot sell any BS IV vehicles after March 31, 2020, and this hard move from BS IV to BS VI would require a well-orchestrated transition not just in OEMs, but also in Tier 1 and Tier 2 suppliers so that we are not left with any dead inventory."

Dr N Saravanan
Chief Technology Officer
Ashok Leyland

presence of sulphur in the fuel. While the BS IV fuels contain 50 parts per million (ppm) sulphur, the BS VI grade fuel only has 10 ppm sulphur content. Also, the harmful nitrogen oxide emissions will be brought down by nearly 70 percent in diesel cars and 25 percent in petrol cars, and cancer-causing particulate matter like PM 2.5 and PM 10 will be brought down by a whopping 80 percent in diesel cars.

Auto and machine makers' take

Ashok Leyland is the second largest commercial vehicle manufacturer in India. On India's leapfrogging from BS IV to BS VI, Dr N Saravanan, Chief Technology Officer, Ashok Leyland, says, "While it is a significant challenge for the industry to make this quick transition from BS IV to BS VI, the industry is gearing up to meet the challenges. OEMs cannot sell any BS IV vehicles after March 31, 2020, and this hard move would require a well-orchestrated



Source: TRUMPF (India) Pvt Ltd

"The decision by the Government is for the good of all, and when it comes to the business of TRUMPF, we are proud to share that we have a very important role to play in empowering Automobile manufacturers to meet the BS VI norms through a unique tool - Laser Technology."

Pradeep Patil
Managing Director
TRUMPF (India) Pvt Ltd

transition not just in OEMs, but also in Tier 1 and Tier 2 suppliers so that we are not left with any dead inventory. The primary technology is in the area of After Treatment system, which is a combination of DOC (Diesel Oxidation Catalyst), DPF (Diesel Particulate Filter) and SCR (Selective Catalytic Reduction). Some of the manufacturers are also expected to make some changes to the engine."

Offering unique Laser Technology

Pradeep Patil, Managing Director, TRUMPF (India) Pvt Ltd, is bullish about TRUMPF's prospects with the new BS VI norms coming in. He says, "The decision by the Government is for the good of all, and when it comes to TRUMPF, we are proud to share that we have a very important role to play in empowering Automobile manufacturers to meet the BS VI norms through a unique tool - Laser Technology." For Automotive companies, to comply with BS VI norms will mean that they will need to invest in technology across

The deadline given to the auto companies is March 31, 2020, after which no new vehicles would be registered that are not BS VI compliant. When implemented, this would be the fastest transition from BS IV to BS VI anywhere in the world.



Source: Toyota Kirloskar Motor Pvt Ltd

“Due to the introduction of BS VI, the parts that we have had to change are mainly powertrain, exhaust and a few other electronic parts. As a result, the main parts that have been introduced are DPF (Diesel Particulate Filter), SCR (Selective Catalytic Reduction), DOC (Diesel Oxidation Catalyst) and Urea Tank (NO_x dosing unit), to name a few.”

Shekar Viswanathan
Vice Chairman & Whole-time Director
Toyota Kirloskar Motor Pvt Ltd

various areas. TRUMPF has cutting-edge laser technology solutions for fuel injection systems, transmission, powertrain, exhaust systems and Body in White (BIW) part production with mass volumes.

The company has proven laser applications in a number of different areas like Laser cleaning, laser cutting, laser welding, laser hardening applications for transmission, power train, exhaust systems etc. It has even developed a laser drilling application where lasers are used as a tool for drilling operations in fuel injection systems.

All these solutions are already proven in other parts of the world and, hence, will help auto makers in India to upgrade their technology and comply with BS VI norms.

Overall, there seems to be a bright future for TRUMPF, and we see our businesses growing exponentially over the next few years as the auto makers and Tier 1 and Tier 2 suppliers adapt to the new technology.



Source: Yamazaki Mazak India Pvt Ltd

“We have seen an increase in demand for our high-performance, high-accuracy machines ever since the Government of India decided to implement BS VI.”

Anil Bharadwaj
Managing Director
Yamazaki Mazak India Pvt Ltd

Innovating to overcome challenges

On being asked for his opinion on BS VI and how this will affect Toyota Kirloskar Motor Pvt Ltd in the long term, Shekar Viswanathan, Vice Chairman & Whole-time Director, Toyota Kirloskar Motor, says, “As a responsible global auto manufacturing company at the forefront in offering advanced and environment-friendly motoring technologies, we are globally compliant with the stringent emission standards. We have the advanced technology required. There are many complexities in upgrading the diesel engine to BS VI not just as an engine design, but also the complete packaging of the power train and related emission control and exhaust treatment components in the vehicle. Some of our vehicles also need SCR to comply to BS VI pollutant levels, which will be an additional component that can be seen. Also, it is not just exhaust gases control, but also the OBD (On Board Diagnostics) parameters that monitor the health of

the engines on BS VI criteria. Thus, striking the right balance between technology and cost has been the bigger challenge for us to make our vehicles comply to BS VI norms.”

The company, he notes, is ready for any future trends in mobility and has even invested in a state-of-the-art Diesel engine manufacturing plant near Bengaluru (Jigani) in India. It is capable of manufacturing diesel BS VI engines with a minimum investment.

“Due to the introduction of BS VI, the parts that we have had to change are mainly powertrain, exhaust and a few other electronic parts. As a result, the main parts that have been introduced are DPF, SCR, DOC and Urea Tank (NO_x dosing unit), to name a few,” adds Viswanathan.

Yamazaki Mazak is one of the world's largest machine makers. Anil Bharadwaj, Managing Director, Yamazaki Mazak India Pvt Ltd, talks of the challenges ahead, “We have seen an increase in demand for our high-performance, high-precision machines ever since the Government of India decided to implement BS VI. Mazak Corporation is a world leader in the design and manufacture of productive machine tool solutions, and we have already been supplying these high-performance machines across Europe, the US and worldwide for Euro VI-related components.” “We have also developed a state-of-the-art controller to enhance machine performance with the development of the ‘Mazatrol Smooth Controller’, which allows for programming everything from simple to complex part geometries and enables the high performance and high precision that is required for BS VI components,” he informs.

BS VI is slated to bring down cancer-causing particulate matter like PM 2.5 and PM 10 in diesel cars by a whopping 80 percent.

Mazak also has a wide variety of new high-performance, high-precision machines – from Turning Centers to Horizontal and Vertical Machining Centers to state-of-the-art Multi-Tasking machines, which will help Indian customers to comply with the stringent tolerances required to machine BS VI components.

At the cutting edge

Gusti Tool Works LLP (GTW) is a total cutting tooling solution provider, predominantly in Special Custom-Built Tooling for high productivity at world-class quality levels. Toshi G Hormusjee, Managing Director, GTW, who is also the Founder and Former President of the Indian Cutting Tool Manufacturers' Association, says, "We are specialists in tooling for fuel pumps (domestic and export) and, thus, are in a prime position to adapt to the changes brought in by the new norms. Our philosophy has always been to provide high-precision and faster cutting solutions to our customers. As the tolerance band keeps getting tighter for components, so does the precision required in cutting tools. We expect the components manufactured for BS VI norms to have closer tolerances and newer materials, and we are ready for this."

"Since our highly experienced team is equipped with world-class machines and measuring instruments, we are ready for the challenge it brings. Apart from manufactured products, we also offer world-class BS VI solutions from our international partners – FMT, Swiss Bore and Micro Tools," he adds.

Artificial Intelligence (AI)

Forms and Gears is one of the oldest fixture builders in the



Source: Gusti Tool Works LLP

"With the deadline for BS VI on the horizon, we are looking forward to a cleaner and a more environment-friendly approach in the auto industry. Our philosophy has always been to provide high-precision and faster cutting solutions to our customers."

Toshi G Hormusjee
Managing Director
Gusti Tool Works LLP

country and Reji Varghese, Managing Director, Forms and Gears, thinks the way forward is by harnessing the power of Industrial AI. He says, "The automakers have and will continue to make substantial investments to up-grade existing models to BS VI. A lot of these investments will require upgradation of fixtures and tooling and not necessarily new investment in machines."

"Anticipating this, we have partnered with a few of the world's leading cutting tool companies to offer a complete turnkey package to the auto makers and Tier 1 suppliers for BS VI conversion - Fixtures, Tooling and Complete Engineering from concept to run offs," he adds.

Together with its partner, ASM Technologies, a company that specializes in AI, Machine Learning and Deep Learning / Neural Networks, Forms and Gears has now developed a product called Smartfix 4.0, which is an Industry 4.0-enabled Fixture leveraging the capabilities of AI and Machine Learning.

In Industrial AI, the process



Source: Forms and Gears

"The automakers have and will continue to make substantial investments to upgrade existing models to BS VI. A lot of these investments will require upgradation of fixtures and tooling and not necessarily new investment in machines."

Reji Varghese
Managing Director
Forms and Gears

known as 'training' enables Machine Learning algorithms to detect anomalies and test correlations while searching for patterns across the various data feeds from multiple sensors mounted on the Fixture. The health and behavior of the Machine, Fixture and Cutting Tools are constantly evaluated and a number of useful outcomes like predictive maintenance of Fixture and Machine, Safety Alerts, Tool Wear Analytics, Cost Per Component Analysis Per Tool etc. are generated on a regular basis. "As emission norms become more stringent and component tolerances become more rigorous, harnessing the power of AI will be the future of manufacturing," stresses Varghese.

Joint effort needed

In spite of all that's being done by the Government and the Auto Industry, the Auto sector is only one of the causes of air pollution. The Government needs to address other urgent environmental issues also on a priority basis if the efforts of the auto makers to move to BS VI are to be effective. 

As emission norms become more stringent and component tolerances become more rigorous, harnessing the power of AI will be the future of manufacturing.

COMPLETE SOLUTION

Mazak is not only manufacturing advanced machines, but also adds value by supplying a complete solution to our customers in India like Tools, Fixture & Automation



Simultaneous 5-axis Machining Center

VARIAXIS i-800T



VARIAXIS i-T series adds turning operation to the simultaneous 5-axis performance of the VARIAXIS i series

- Tilting / rotary table plus high rigidity machine construction ensure high accuracy machining of complex workpiece contours
- Variety of spindle specifications available for high speed machining of aluminum or machining of difficult-to-cut materials such as stainless steel, nickel-alloys and titanium
- For increased versatility, models are available with turning capability in addition to simultaneous 5-axis machining

YAMAZAKI MAZAK INDIA

115, Pune Nagar Road, Sanaswadi, Pune. 412208.

www.mazakindia.in





Single Column Machine for Large Workpieces

VORTEX i-800V/8



Higher productivity for multiple surface machining 5-Axis machining and turning

- Machine large workpieces in a single setup
- Improved accuracy and reduced in-process inventory
- Tilting milling spindle for machining side surfaces as well as slanted surfaces

DRIVING INNOVATIONS

In an exclusive interview with MMI's Chief Editor Soumi Mitra, Dr Heinz-Jürgen Prokop, Chairman, VDW (German Machine Tool Builders' Association), sheds light on Asia's growing presence in EMO Hannover; the show's focus on Artificial Intelligence (AI) Technologies and Additive Manufacturing; VDW's initiative to support start-up companies; and umati, a quantum leap in the world of manufacturing. Excerpts...



Dr Heinz-Jürgen Prokop, Chairman, VDW (German Machine Tool Builders' Association)

exhibition space. In my view, the Taiwanese and Chinese manufacturers want to rise their exports. Meanwhile, they also offer technology that could be in demand internationally. Due to its international audience, EMO Hannover is certainly the right and most efficient platform to test this.

Manufacturing players from all over the world are looking forward to umati (universal machine tool interface), which is regarded as a breakthrough in the manufacturing world. Please elaborate on the objective behind umati.

Dr Prokop: Everyone is talking about Industry 4.0 and wants to exploit the value creation potential. But this requires a standard interface for connecting machine tools from different manufacturers to a higher-level software system. That is exactly the goal of umati. Thanks to the industry initiative of the VDW (Association of German Machine Tool Manufacturers), companies - especially small and medium-sized enterprises - can advance the automation of their production much faster and cheaper. With umati, we are creating an important building block for the introduction of various value-added services making Industry 4.0

EMO Hannover 2019 is slated to be a mega affair with one of its distinctive features being Asia's growing presence in the leading Metalworking trade fair. How do you perceive the reasons for this increase in the participation?

Dr Heinz-Jürgen Prokop: Around 2,200 exhibitors from 47 countries have registered for

EMO Hannover 2019. In fact, the number of Asian exhibitors has increased from 21 percent in 2017 to 31 percent in 2019. The largest Asian exhibitor contingents come from Taiwan (239), China (235) and Japan (99). Taiwan and China recorded the highest increases in terms of exhibitor number and

SOUMI MITRA
Editor-in-Chief
Modern Manufacturing
India
soumi.mitra@
magicwandmedia.in



Source: VDW

applications possible for the first time. Only with this standard interface, it is possible to fully exploit the value creation potential of the Industry 4.0 concept. This, in turn, allows companies to survive in international competition in a long-term perspective.

How would VDW as a premiere technology association facilitate manufacturers to adopt and implement umati in their manufacturing processes?

Dr Prokop: Under info@umati.info our experts are available for all questions and help gladly with the practical conversion. Also, at the end of the year, the VDW is planning various support programs. Interested parties will be provided with comprehensive documentation on the topic and implementation guidelines by the VDW.

It is slated that Artificial Intelligence (AI) Technologies will contribute 40 percent of production processes by 2025 and increase economic growth in 16 industries by an average of 1.7 percent. Against this backdrop, how do you think the AI will affect the Internet of Things (IoT) in manufacturing?

Dr Prokop: Not only governments, but also research institutions from production science have discovered the topic for themselves and invest a lot of money, time and know-how in the implementation of AI. For example, in Germany, the WGP (Wissenschaftliche Gesellschaft für Produktionstechnik) is currently working on a position paper to be published in September that is intended to be a wake-up call for companies to address the topic of AI. In addition, it will be shown how AI can be systematically integrated into production processes. First applications in the machine tool



Source: VDW

“Everyone is talking about Industry 4.0 and wants to exploit the value creation potential. But this requires a standard interface for connecting machine tools from different manufacturers to a higher-level software system. That is exactly the goal of umati.”

**Dr Heinz-Jürgen Prokop
Chairman
VDW (German Machine Tool
Builders' Association)**

environment are, for example, the self-learning optimization of process or cutting parameters. Due to the increasingly digitized and networked production, we can assume that AI will further increase the automation and efficiency of production in the future. The fact that new business models are also emerging as a result to AI is demonstrated by the start-ups exhibiting at EMO Hannover 2019.

This edition of EMO Hannover has a special area dedicated to Additive Manufacturing (AM) showcasing the entire value chain of AM. How would 3D Printing and AM change the course of doing business in the metalworking sector in the coming years?

Dr Prokop: Additive processes are becoming an increasingly important factor. This applies above all to the automotive and aircraft industries, but more and more products are also being printed in medical technology. The aim is to find new product properties and applications that justify the high costs of additive production. There are increasingly more convincing examples to this.

The technology itself must be further optimized, as not all materials are suitable yet and the surface quality of the workpieces is not yet high enough. But also, for this challenge, research is constantly developing new approaches and solutions, such as combination machines. So-called hybrid machines combine the advantages of additive processes with classic cutting technologies.

EMO Hannover's initiative to support start-ups in the production environment in the form of 'Digitalisation in Production' award, with €10,000 prize money, deserves a special mention here. It must have garnered an amazing response from budding entrepreneurs. Kindly tell us about it.

Dr Prokop: In fact, it was possible to collect more than 250 applications for the first edition of the start-up competition 'Digitisation in Production'. We were very pleased, because people in Germany often complain that too few people dare to take the step into self-employment. However, there are many ideas and activities in the production environment. The jury will meet in the next few days and select the best applications. Up to six main prizes and up to 15 recognition prizes will be awarded. The price-giving ceremony will be on the second EMO day, September 17, as part of a festive event. However, the winners will not only receive the prize money of € 10,000, but also a written assessment of their founding idea on strengths, weaknesses, opportunities and risks. For young start-up companies, this can sometimes be worth more than the sum of money. 

The winners of the start-up competition, 'Digitisation in Production' will not only receive the prize money of € 10,000, but also a written assessment of their founding idea on strengths, weaknesses, opportunities and risks. For young start-up companies, this can sometimes be worth more than the sum of money.

GETTING FUTURE-READY

The highly-awaited world's premier metalworking trade fair, EMO Hannover will open its doors on 16 September 2019. Following its tradition, the 22nd edition of the event is to cover a wide spectrum of the metalworking industry and usher in manufacturing players from far and wide. The highlight this time is a significant peak in Asian participation including India. A look at what all our players plan to present there to the industry at large and their good reasons behind it...

POONAM PEDNEKAR
Chief Copy Editor
Magic Wand Media Inc
poonam.pednekar@
magicwandmedia.in



Source: VDW

in the world. With the current share of exhibitors comprising 64 percent from Europe, 31 percent from Asia, 4 percent from Americas, and 1 percent others, it is rightly termed as the world market at one place. From net exhibition space of 178,000 sq mt, 2,107 exhibitors from 47 countries are to showcase their best.

India is truly shining

Among the various highlights of EMO Hannover 2019, there is one which makes us extremely proud. The upcoming edition has a strong participation from Asia, which is a significant 31 percent. From India, more than 40 exhibitors including Ace Designers Ltd, Ace Manufacturing Systems Ltd, Birla Precision Technologies Ltd, Broach Technology India Pvt Ltd, Miranda Tools Pvt Ltd, Dutch Tech Tools Pvt Ltd, ETA Technology Pvt Ltd, Fenwick and Ravi, Grind Master Machines Pvt Ltd, IND-SPHINX PRECISION Ltd, Khushbu Honing, Pragati Automation Pvt Ltd, Precision Machinekraft Pvt Ltd, Shobha Industries Pvt Ltd, Sphoorti Machine Tools Pvt Ltd, Suntech Landriani Machine Tools Pvt Ltd, UCAM Pvt Ltd, Micromatic Grinding Technologies Ltd, Forbes & Company Ltd, Jyoti CNC Automation Ltd, are to present

Organized by the VDW (German Machine Tool Builders' Association), EMO Hannover 2019, under the theme of 'Smart technologies driving tomorrow's production!', promises to be a delightful spread of the latest and advanced products and services covering all production areas relevant to machine tools and production systems - ranging from machining and forming, precision tools, accessories and control technology, system elements and components for

automated manufacturing, right on up to inter-connecting equipment and industrial electronics.

The world's leading trade fair for metalworking has come to be known as the mecca for the metalworking players from all over the globe who make it a point to attend the biennial show and explore exciting innovations with the view to become future ready.

The global participation has made EMO Hannover the most international trade fair



Source: UCAM Pvt Ltd

“Our agenda this time is to meet machine tool builders and dealers from Poland, and manufacturing companies from Italy, Turkey, and Brazil. These are the countries we are looking at to expand our exports.”

Indradev Babu
Managing Director
UCAM Pvt Ltd

their indigenous ‘Made in India’ offerings.

Jai Ho at EMO!

With the Government pegging its expectations on the manufacturing sector to achieve its target of \$5 trillion economy by 2025, the industry has to have immense potential. EMO Hannover makes for the perfect platform to showcase the Indian industry’s manufacturing mettle to the world and gain the much-needed exposure for its further growth. A few of our exhibitors have presented their take as to what the event means to them and their innovative displays:

UCAM Pvt Ltd
Hall & Stand: 12 / E90
www.ucamind.com

UCAM has been participating in EMO from 2003 and has not missed any show since then.



Source: Dutch Tech Tools Pvt Ltd

“Since we primarily serve the European market, the platform of EMO 2019 can help us expand our distribution and market presence in the continent.”

Subrata Kumar Nag
Chairman & Managing Director
Dutch Tech Tools Pvt Ltd

Sharing the company’s goals for EMO this edition, Indradev Babu, Managing Director, UCAM Pvt Ltd, states, “We aim to connect with majorly two kinds of customers - OEMs i.e. machine tool builders, and dealers and distributors from various parts of the world. EMO attracts machine tool builders and other machine manufacturing people from all over. Our agenda this time is to meet machine tool builders and dealers from Poland, and manufacturing companies from Italy, Turkey, and Brazil. These are the countries we are looking at to expand our exports.”

Dutch Tech Tools Pvt Ltd
Hall & Stand: 3 / B46
www.dutchtechtools.com

Subrata Kumar Nag, Chairman & Managing Director, Dutch Tech Tools, explains his game plan, “We primarily serve the European market. EMO 2019 can help us expand our distribution and market presence in the continent.”

The company is to launch two new products at EMO 2019 with newer and advanced

geometries along with the latest and upgraded surface coatings. These products are for machining a wide range of materials including difficult-to-cut. “We are primarily targeting the Aerospace and Medical industries with these products,” he shares.

Jyoti CNC Automation Ltd
Hall & Stand: 27 / D76, D84
www.jyoti.co.in, www.huron.fr

EMO, with all major manufacturers of production technology, provides an innovative platform for metalworking machines, solutions and services, believes Vikas Taneja, Vice President - Sales, Jyoti CNC Automation. “We intend to boost our customers’ success in the area of Industry 4.0 with our latest offering 7th Sense, which we are to showcase at the event. It includes intelligent component for process monitoring and ensures smooth dataflow with maximum security and much more.”

At Jyoti Huron pavilion, one can catch sight of Tachyon 5 and Tachyon 7 from the Tachyon Series of High-Speed Drill Tap Center. Tachyon is a unique concept column fast moving machine suitable for fast drilling and tapping with continuous production line that requires precision component output in mass. The concept of base and column structure with all the moving axis mass on the column helps very high dynamics while maintaining high machining accuracy. The unique feature of Tachyon is its integral workpiece changer which operates without any pneumatic or hydraulic system. Tachyon is with 10,000 rpm direct coupled spindle with high ramp-up time of less than 1 sec with high rapid of 60m/min. It has fast Twin-Arm ATC of 16 stations with tool change time of only 1 sec. Tachyon series

Indian economy has grown resilient to internal and external disruptions and the Indian machine tool industry has been able to tide over it and move ahead. This has been attributed to the fundamentals of the industry being strong. The industry grew at around 30% in 2018-2019. Machine tool production for 2018-2019 is estimated to be around €1.2 billion and consumption was around €2.7 billion.



UCAM Pvt Ltd
Hall & Stand: 12 / E90
www.ucamind.com

Source: UCAM Pvt Ltd



Source: Dutch Tech Tools Pvt Ltd

Dutch Tech Tools Pvt Ltd
Hall & Stand: 3 / B46
www.dutchtechtools.com

caters to automobile, medical and electronics sectors which requires faster drill tap operations.

**Ace Manufacturing Systems
Hall & Stand: 17 / F11
www.amsl.in**

"We aim to capture the attention of the European market with our machining centers and automation solutions known for enhancing productivity in the manufacturing domain. We are trying to expand our presence in the western market space," shares Muralidhara Rao, Chief of Supply Chain Management and Exports, Ace Manufacturing Systems Ltd.

The company plans to leverage the platform to create brand awareness and showcase its unique and low-cost products and solutions to the European and the Western market. "EMO will also serve as a live research session wherein we would receive feedback on our machines and technological capabilities," he adds. "Apart from these, we look forward to meet some potential corporate customers, partners and dealers from the whole of Europe and the West who can help us establish business in areas uncharted by AMS. For any export business, establishing a local partner for sales and servicing plays a crucial role in customer satisfaction and hence, serving the purpose of strengthening the

Among the various highlights of EMO Hannover 2019, is the strong participation from Asia, which is a significant 31 percent.



Source: Jyoti CNC Automation Ltd

"We intend to boost our customers' success in the area of Industry 4.0 with our latest offering 7th Sense. It includes intelligent component for process monitoring and ensures smooth dataflow with maximum security and much more."

**Vikas Taneja
Vice President - Sales
Jyoti CNC Automation Ltd**

global market," he states. This edition, AMS is specifically focusing on promoting its Gemini XL twin spindle vertical machining center into the European market. "The VMC is in congruence with the EMO's current theme 'Smart technologies driving tomorrow's production'. It has all the inbuilt features that can cater to industries across Europe and the far West," informs Rao.

**Miranda Tools Pvt Ltd
Hall & Stand: 4 / G107
www.mirandatools.in**

Miranda Tools already has a strong reliable base in the European Market. Prashant Patkar, Vice President,

**Jyoti CNC Automation Ltd
Hall & Stand: 27 / D76/D84
www.jyoti.co.in, www.huron.fr**



Source: Jyoti CNC Automation Ltd



Source: Ace Manufacturing Systems Ltd

"Apart from showcasing our unique, cost-effective offerings, we aim to meet some potential corporate customers, partners and dealers from the whole of Europe and the West who can help us establish business in areas uncharted by AMS."

**Muralidhara Rao
Chief of Supply Chain
Management and Exports
Ace Manufacturing Systems Ltd**

International & Domestic Sales & Marketing, Miranda Tools, shares, "We are to present to the visitors our premium quality cutting tools and make them gauge our competence vis-à-vis other players." Through EMO, the company wants its prospects to understand why it holds such a position and why should they be its associates in the coming time.

The company is to showcase its Jobber Drills that are made from M2 and M35 grade Steel with options of Bright Finish, Steam Blue Finish, Amber Finish and Tin, TiALN, TiCN Coating. The manufacturing standards

**Ace Manufacturing Systems Ltd
Hall & Stand: 17 / F11
www.amsl.in**



Source: Ace Manufacturing Systems Ltd



Source: Miranda Tools Pvt Ltd

“We have a strong reliable base in the European Market. We want to present to the visitors our premium quality cutting tools and make them gauge our competence vis-à-vis other players.”

Prashant Patkar
Vice President
International & Domestic
Sales & Marketing
Miranda Tools Pvt Ltd

are DIN 338 (German). Jobber Drills can be applied for Steel, Stainless Steel, Cast Iron, Brass, Aluminum & Non-Ferrous Metal. The product size varies from 1.00mm to 20.00mm. The same are available in equivalent inch sizes.

Forbes & Company Ltd
Hall & Stand: 4 / A82
www.totem-forbes.com

According to Kshitij Chandler, General Manager, International Sales & Marketing, Forbes & Company Ltd, Forbes & Company's presence at EMO from 2011 till 2017 has been an opportunity for global outreach. “We are sure EMO 2019 will similarly catapult us ahead of our peers. We also look forward to learning about new technologies from the industry and strengthening existing relationships and building new ones during the exciting six days of EMO. We are geared up to put our best foot forward to showcase our excellence in technology and service,” he states.

Miranda Tools Private Limited
Hall & Stand: 4 / G107
www.mirandatools.in



Source: Miranda Tools Pvt Ltd



Source: Forbes & Company Ltd

“We are sure EMO 2019 will catapult us ahead of our peers. We look forward to learning about new technologies from the industry and strengthening existing relationships and building new ones during the event.”

Kshitij Chandler
General Manager
International Sales & Marketing
Forbes & Company Ltd

The company is to offer: Totem product line including High-Performance Threading Taps in HSSE, HSSE-PM material. Solid Carbide End Mills & Drills, Tungsten Carbide Rotary Burrs, Carbon Steel Taps, Dies and Die Nuts, High Speed Steel Drills and Annular Cutters.

Bradma product line that includes Electric & Pneumatic Pin Marking Machines, Laser Marking Machines and Industry Automation which includes Customized Marking Workstations, Vision & Monitoring System, Conveyor System, Robotic Application, Conventional Marking Machines, etc. BBBB product line that includes plated and natural Spring Lock Washers.

Micromatic Grinding Technologies Ltd
Hall & Stand: 11 / F01
www.micromaticgrinding.com

“EMO is one of the most important events in the machine tool world, wherein one can showcase one's new products and technology to the world. Micromatic Grinding Technologies (MGT), through EMO, looks at strengthening its overseas distribution channel by finding new partners and



Source: Micromatic Grinding Technologies Ltd

“EMO is one of the most important events in the machine tool world. MGT, through EMO, looks at strengthening its overseas distribution channel by finding new partners and making itself known as a reliable and technology-oriented brand from India.”

Prashant Godse
AGM - Exports
Micromatic Grinding Technologies Ltd

make itself known as a reliable and technology-oriented brand from India,” says Prashant Godse, AGM - Exports, Micromatic Grinding Technologies Ltd. MGT will be showcasing a CNC Universal Grinder, the FLEXI series. As the name denotes, it is a Universal Cylindrical Grinder performing OD, ID and Shoulder grinding in a single chucking to achieve the highest precision in size and geometry. Such machines are very popular in Europe. Through EMO, the company aims to make a foothold in this lucrative market. FLEXI is available in 3 variants - 400mm, 630mm and 1000mm ABC. The machines are offered in more than 10 different configurations of OD, ID Grinding heads along with MGT's customized menu-driven screens for quick set-up and programming. 

EMO Hannover is the perfect platform to showcase the Indian industry's manufacturing mettle to the world and gain the much-needed exposure.



Source: Micromatic Grinding Technologies Ltd

Micromatic Grinding Technologies Ltd
Hall & Stand: 11 / F01
www.micromaticgrinding.com

EXCELLING IN THE AIR

The high demands on quality and the enormous pressure of global competition are forcing manufacturers and machine suppliers alike to develop ever productive manufacturing solutions for safety-critical aerospace components. The DMG MORI Aerospace Excellence Center, with its wide range of services, aims to support its customers with regard to whatever is asked of them.

The DMG MORI Aerospace Excellence Center engineers and implements future-oriented process solutions for the most demanding applications in the aerospace sector.



Source: DMG MORI

The global aerospace sector has grown consistently in recent years. This growth is driven by the need for new fuel-efficient engines and the resulting new generations of aircraft. Single-aisle planes are expected to make up around 75 percent of the expected total number of passenger aircraft in the next 20 years. These include, in particular, the new A320neo Airbus family and the Boeing B737MAX. Even wide-body aircraft such as the Airbus A350 are steadily replacing older and

less efficient machines in this class. The enormous capacity requirements arising from the growth in global passenger traffic, especially in Asia, is the driving force in the industry.

Providing the best possible solutions

DMG MORI generates several million Euros from the sale of machining solutions in the aerospace sector. Due to the strict regulations imposed on the production of airborne and safety-critical components, customers in the aerospace industry have very specific production requirements.

It is exactly this vital competence that is concentrated in the DMG MORI Aerospace Excellence Center. We support users with our over 20 years of technology experience, ensuring the internal build-up of knowledge in the relevant markets, so our customers are offered the best possible solution by DMG MORI for their respective needs.

The Aerospace Excellence Center is involved in all phases of customer and order acquisition. We advise our customers on the optimization of their current machining processes and work with them from the very outset

MICHAEL KIRBACH
Director
DMG MORI Aerospace
Excellence Center
stine.meyer@
dmgmori.com



MEASUREMENT ERROR

MEASUREMENT PRECISION



The Marposs **WRP60** radio frequency system automatically detects axis position to enable part inspection on large, 5-axis milling machines and machining centers and applications producing deep parts. You get improved quality and reduced scrap. **Marposs means precision.**

www.marposs.com

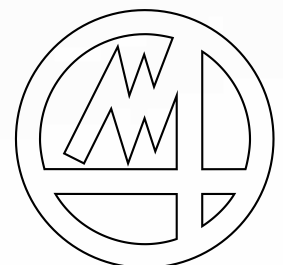

MARPOSS
YOUR GLOBAL
METROLOGY
PARTNER

MARPOSS INDIA Pvt. Ltd. 147, Sector 7, IMT Manesar 122 050 - Tel. +91 124 4735700 | sales@in.marposs.com

to develop the planning of the so-called green field projects. Special branch-specific and complex application-based machine tool requirements are incorporated into the customized machine solutions we realize for our customers.

Close cooperation with customers

The cooperation begins in the very early phases of a project. Feedback from customers is what ultimately drives our further and new development of machines and their equipment. This may result in special customer-specific solutions that we sometimes adopt as standard options at a later date. Added to this is our cooperation with scientific partners such as institutes and universities worldwide and numerous industrial partners primarily from the field of DMG MORI Qualified Products.

Bumps in the road

The use of hard-to-machine materials is one of the challenges in the machining of aerospace components. New high-temperature materials produced using powder metallurgy technology or ceramic composites will reach their limits in future where machinability is concerned.

Secondly, the production trends in the aerospace sector include automation, digitization and

an integral mindset for the respective process chains. Automation in this case is not just about handling, but also about focusing on the process in order to develop overall processes that are more reliable and reproducible. For example, the green-button process, which is a safe and reliable process that manages without any manual interventions due to automatic monitoring and control.

Process optimization is vital

Today's quantities and high-quality components justify these efforts more than ever. Digitization is a key aspect here. For example, the use of DMG MORI Technology Cycles or our app-based control and user interface CELOS. Producers of aerospace components are making more use of the possibilities of digitization within the machine in order to facilitate better analysis and comprehension and, thus, optimization of processes – even to control them adaptively where applicable. Many developments are also being driven by universities so they can be introduced subsequently into a company's day-to-day production with an acceptable degree of maturity.

Showcasing innovation at EMO 2019

We will be presenting solutions that use digitization to achieve safer, more reliable and, therefore, more productive processes, like the green-button processes already mentioned. We will be demonstrating the innovative DMG MORI Technology Cycle easycenterSET on a DMC 125 FD duoBLOCK machine. This comprises an automatically adjustable plate between the pallet and the component fixture that measures the center offset of the pre-centered part and

centers it automatically with an accuracy of a few microns. The documentable result offers customers a high level of process reliability during mill-turn operations, especially when using automation solutions.

Must-see live demos

Our highlight in the aerospace field is an extensive process chain for the production of a turbine disk made of Inconel 718 on the DMC 65 FD monoBLOCK. Starting with the engineering phase with the help of Siemens NX CAM, Renishaw Productivity+ and Vericut, we will be presenting digital solutions for machine setup through to actual machining. Various ceramic, CBN and carbide tools from Sandvik Coromant will be used. We will also be demonstrating the grinding integration. The quality of the machining will be monitored and where necessary regulated during and after the process by means of in-process measurement. Using the Renishaw Sprint system, components that are difficult to measure and with properties such as bore radiuses or processing steps typical for such parts will be measured and evaluated. The Tool Control Center (TCC) captures the forces and bending moments on the tool parallel to processing, in order to demonstrate the capability of such systems for the production of safety-critical components such as turbine disks. The aim for the future will be to make all the process-relevant input and output data available to the customer via a simple interface. This will enable the creation of further analysis for verification of the results. In future, it should be possible to draw conclusions about process stability and to detect any process anomalies that arise in real-time.

Producers of aerospace components are making more use of the possibilities of digitization within the machine in order to facilitate better analysis and comprehension and, thus, optimization of processes.

The Tool Control Center (TCC) captures the forces and bending moments on the tool parallel to processing, in order to demonstrate the capability of such systems for the production of safety-critical components such as turbine disks.



Source: DMG MORI



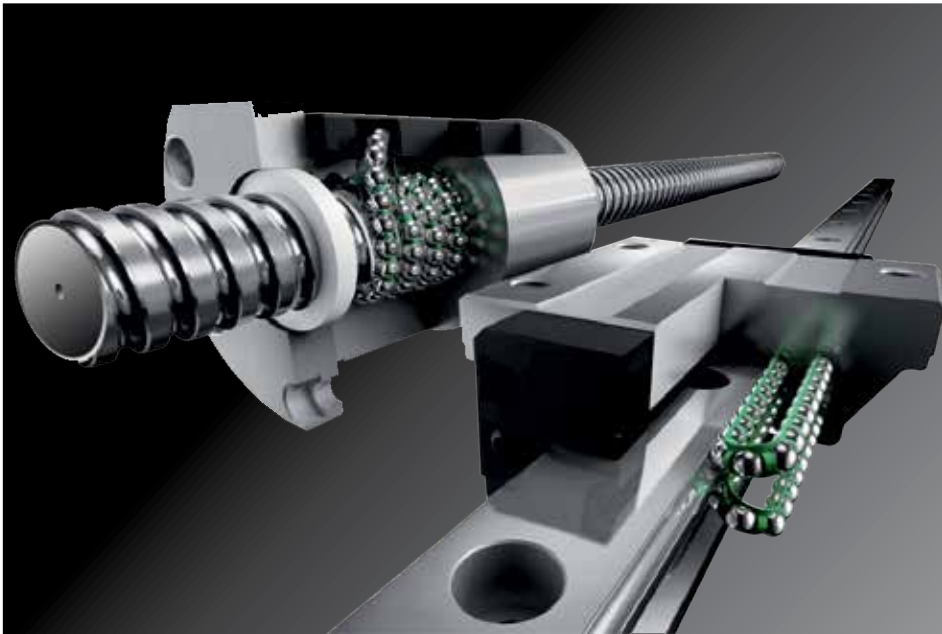

THK
The Mark of Linear Motion



LM Guide



Ball screw



Cross Roller Ring



LM Bush

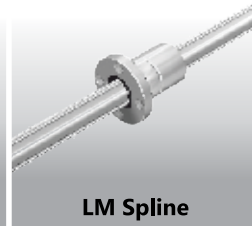

LM Spline



Grease



Cam - Roller Follower



Rod End - Link Ball



Cross Roller Guide



Ball screw & Belt Linear Actuators

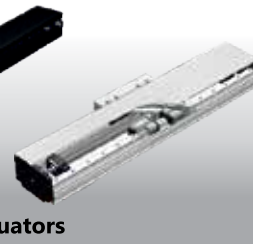

OUR OTHER PRODUCTS



LM Guide Clamp



Curvic Coupling



Gear, Rack & Pinion



Ball Transfer Unit



Mist Cleaner



Large Diameter Ball screw



Precision Planetary Gearbox



Locknut + Locking Element

APEX[®]
PRECISION

Amcats Pvt. Ltd.
Apex Precision Mechatronix Pvt. Ltd.

303 - 308, Krishna Bhuvan Annexe, 22-B, Govandi Station Road, Deonar, Mumbai - 400088
Tel: +91 22 6146 4444 Email: sales@apexprecision.co.in URL: www.apexprecision.co.in
MUMBAI BANGALORE CHENNAI HYDERABAD AHMEDABAD



THE SKY'S THE LIMIT

Following is a compelling account of Kencoa Aerospace US-based operation's turning to Mastercam® CAD/CAM software for its machining solutions. The software not only helps the company work on challenging orders, but does it with an unbelievable ease.

Mastercam Roughing
Track Screenshot

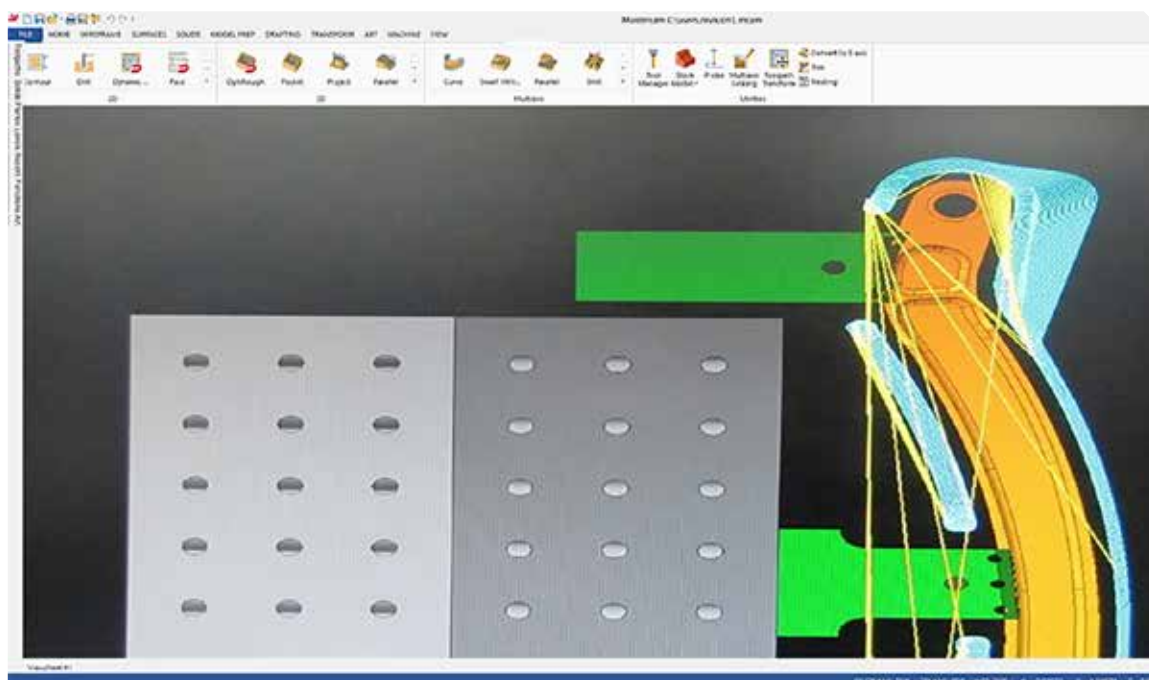

Source: CNC Software, Inc.

When 20 years ago Kencoa Aerospace began its operations, it was a small company focused on defense applications. According to Troy Boston, Engineering Manager, US-based Operations, Kencoa Aerospace, the company has now progressed into commercial aerospace and produce diverse parts for well-known clients such as Boeing, Lockheed Martin, Gulf Stream, and more.

Headquartered in Korea, the US-based aerospace operation is a Tier-1 supplier of multi-axis precision machined aerostructures, jet engine components, and major assemblies of commercial, military, and

business/regional jets.

"We machine anything from plastics, stainless steel, titanium, all the way up to Inconel," he states. The part sizes the company creates can range from the size of a quarter up to 20-foot long. The majority of these parts are internal structural components for airplanes and can range anywhere from wing components to cargo floor skins.

Mastercam software

To create the parts needed for these defense and commercial aerospace clients, Kencoa turned to Mastercam® CAD/CAM software (CNC Software, Inc., Tolland, CT) for its machining solutions.

The software allows Kencoa's programmers to work on challenging orders including those with specifications that require holding close tolerances where their true position is 0.001 or a diameter that is +/- 0.0003" to 0.0010".

"What has impressed me over the last several years has been the OptiRough toolpath and how it has progressed and how easy it is to use. You can basically set the size of your stock, and even for a large hog-out, within a few minutes you can have a very good roughing program to be able to remove large amounts of material without a lot of programming time," shares Boston.

Source: CNC Software, Inc.

- ◆ Advanced Technologies for the Next Generation
- ◆ Solid Support for Day-to-Day Comfort
- ◆ Optimum Solution for the Future

MITSUBISHI ELECTRIC CNC Solution The Best Partner for Your Success

Our single goal is to minimize the downtime while maximizing the productivity of every Mitsubishi Electric product. The more time you spend using our products, the better your business runs.



This is the MITSUBISHI CNC business philosophy. All the staffs who are committed to MITSUBISHI CNC business wish to be "the best partner for customers aiming at global and future-oriented development". We will continue our efforts with the aim that our CNCs be great help to the customers.

Contact

Mitsubishi Electric India Pvt. Ltd.

CNC Technical Centre, Plot No. 56, 4 Main Road, Phase 3
Peenya Industrial Area, Bangalore-560058, Karnataka.

Tel.: +91(80)465 52121, Fax.:+91(80)465 52147

14th
ENGIMACH
4|5|6|7|8 DEC 2019
The Exhibition Centre, Gandhinagar, Gujarat, INDIA

Visit us at:
Hall 11, Stall 53



Source: CNC Software, Inc.

“What has impressed me over the last several years has been the OptiRough toolpaths and how it has progressed and how easy it is to use. You can basically set the size of your stock, and even for a large hog-out, within a few minutes you can have a very good roughing program to be able to remove large amounts of material without a lot of programming time.”

Troy Boston
Engineering Manager
Kencoa Aerospace

Now the company’s machines can run aluminum upwards of 400-in/min. Even with titanium, it is able to run its machines at over 100-in/min.

Faster production

Some particular parts, like those created for Spirit Aerosystems, are now much faster to make for Kencoa. “A model can come in from the customer through CATIA (Read/Write for Mastercam translator, MoldPlus SA) and it can be saved and opened into Mastercam. With one particular part, we were able to bring in the forging models and use that as stock,

which cuts down on some of the roughing, how many roughing toolpaths are needed, or how much motion that it creates by having that stock model,” Boston explains.

For this, Kencoa used the OptiRough toolpaths, 2D Dynamic toolpaths, and then the traditional finish contour toolpaths. The majority of the material was removed with solid carbide end mills. “To do a rough and finish operation was around an hour and half total time, but years ago it would have been much more complicated and taken a much longer time to complete,” he notes.

Before using this software, the feed rates on the part would have been around 5- to 10-in/min, compared to the toolpaths that can now run up to 114-in/min.

This is only the tip of the iceberg in terms of how much time the software is saving Kencoa Aerospace. When forgings come in from a customer that requires Inconel parts, and the program needs to be modified because the forging is actually larger than anticipated, the company can modify the program and be up and running within a day and a half, or sometimes less.

Not all lead times can be this fast due to the complex nature of the parts required by the clients. Some aircraft parts have a four- to five-week lead time, while parts for NASA and the International Space Station can be an 18- to 24-week lead depending on processing.

Another variable is that some of these parts must go through a stringent cleaning process and must be in air-tight, sealed containers when they leave the Kencoa shop.

Working in solid models

One more time-saving feature Kencoa enjoys is the ability to work directly in the solid models imported from CATIA. Sometimes a part might be missing geometry or even missing a face on the solid. It could even be that the radius blend is not clean, or the radius itself could even be missing just due to the way the solid comes in.

“Now, through Mastercam, we have the capabilities to fix that solid and that is a big advantage when it comes to machining. We don’t have to go in and recreate the solid, we can just fix the existing solid and start machining from there,” explains Boston.

Plentiful other options

Boston emphasizes that the company chose this software for its compatibility with all of the machines in the shop. Programmers rely on its Verify function, which allows them to see all fixtures, tool holders, and other parts on the machine. They can virtually run the program to ensure there will be no collisions or tool breakage during the machining process.

The software offers a lot of options and, as Boston says, it’s not just for machining at Kencoa. “We can use it for fixture design, assembly, and many different things.” With so many programming options for its 4- and 5-axis vertical machining centers, CNC turning centers, and 5-axis machining center, the sky’s the limit for this machining crew. 

Sometimes a part might be missing geometry or even missing a face on the solid. With Mastercam’s CAD/CAM software, Kencoa now has the capabilities to fix that solid, which is a big advantage when it comes to machining.

OptiRough toolpaths for the track



Source: CNC Software, Inc.

Aluminum frame splitter for Spirit Aerosystems



Source: CNC Software, Inc.

INTRODUCING

NEW FEATURES

ON

LTP-2 LM 500

THE MOST VERSATILE MACHINE FOR PIPE TURNING

**A2-15
SPINDLE**

Ø250mm
SPINDLE BORE

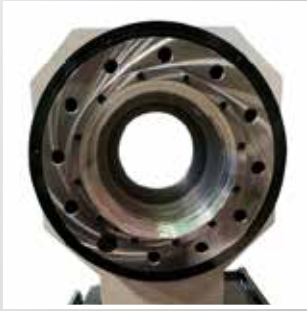

**ROBOT AUTOMATION
FOR COUPLER**



**ACE DESIGNERS
MAKE WORK HOLDING
UP TO Ø 250 BORE**



**BAR FEEDER AUTOMATION FOR
COLUMN PIPE THREADING**



STAYING CLOSE TO THE CUSTOMER

One of the several things contributing to TRUMPF India's massive success is its customer-centric approach which permeates every aspect of the company's business. The leading supplier of Sheet Metal Machines and Laser technologies has its vision all chalked out by being in its customers' proximity and gauging their needs even before they realize.

TRUMPF (India) Pvt Ltd celebrated its 13th anniversary in July this year and owes its remarkable success attained over the years largely to its customers who are based in India, Bangladesh, and Sri Lanka. "It's with the prodigious support from our customers that we have reached this milestone," notes Pradeep Patil, Managing Director, TRUMPF (India). It was in 2006 that the company embarked on its journey with an office in

Baner (Pune) with mere three employees. "Today, we stand tall with our state-of the art 'Customer Experience Center' in Hinjewadi, Pune with over a hundred employees stationed across various locations in India," he shares with evident pride. The company has always kept customers at its very core, and while doing so it has evolved what is known to be a customer-centric organization. With focus on its customers at their ground level, it has found a way to hear them better. "We are driven to get closer to our customers. In 2017, we opened our first regional office and

regional spare part warehouse in Bengaluru to cater to the needs of our customers from South India. We will have another regional office and warehouse in the North before the end of 2019," informs Pradeep Patil. This growth, he stresses, was unthinkable without the trust and support from its customers, business associates and employees. Its Hinjewadi facility is spread across 2.5 acre, and the growth in sales turnover has been double-digit for the last 3 consecutive years in India, and for the next fiscal year, the company aims at continuing this growth pattern.

POONAM PEDNEKAR
Chief Copy Editor
Magic Wand Media Inc
poonam.pednekar@
magicwandmedia.in



TRUMPF India's 2.5 acre facility at Hinjewadi, Pune



Catering to a wide range of customers

As a high-tech company, TRUMPF India provides manufacturing solutions in the fields of Machine tools, Laser technology, and Electronics. "One-stop solution and single window support for sheet metal applications has made us the preferred choice of our customers from various promising industries in India like Infrastructure, Railways, Automotive and Aerospace, Switchgear etc.," shares Pradeep Patil, adding that Infrastructure and Railways are primary revenue generators for TRUMPF India.

TRUMPF's 2D Laser Cutting Machine with multiple outputs of Laser is the most preferred solution in the Indian market. "Entrepreneurs are changing their way of looking at capex investments. Their main goal is to buy the best machine and maximize the utilization of resources. That gives them a competitive edge in their respective markets," he notes. This 2D Laser Cutting Machine provides both the possibilities of Cutting and Welding - The first output of Laser source is used for Laser Cutting and the second one can be used for Laser Welding, one after the other.

This saves upon the investment on another source for Laser Welding. "Though it does not sound easy, our users such as in railways bogie manufacturing etc. are practically using the same for serving their customers," informs Pradeep Patil.

Laser sources for various applications

TRUMPF offers 'Power of Choice' with 8 different types of Laser sources suitable for different industrial applications including Cutting, Cladding, Welding, Hardening, and Marking. "For



Source: TRUMPF (India) Pvt Ltd

"One-stop solution and single-window support for sheet metal applications has made us the preferred choice of our customers from various promising industries in India like Infrastructure, Railways, Automotive and Aerospace, Switchgear etc."

Pradeep Patil
Managing Director
TRUMPF (India) Pvt Ltd

a good Laser-based industrial solution, the initial investment may look high, so return on investment matters the most. With our application knowledge and wide experience, we offer support in selecting the right Laser based on productivity requirements of an industrial application," he states.

Other than general applications, TRUMPF Lasers are becoming a benchmark in Additive Manufacturing or Metal 3D Printing, E-mobility and BS VI applications. The company offers best-in-class 3D Printing production systems that are used in various industries like Medical implants, Tools and Dies, Automotive and Aerospace. With regard to E-mobility, Laser Welding of copper and its alloys play a major role in the production of Lithium Ion batteries. With TRUMPF's proven solutions in this field, it is already geared up to support its customers in India as well. Its proven Laser technology in fuel injection mechanism, transmission, powertrain, exhaust system, Body in White (BIW) part production with mass volumes is slated to contribute

majorly in the transition of India's automotive landscape to BS VI norms.

TRUMPF has been among the top international players catering to the Laser Cutting market in India for a long time. Pradeep Patil congratulates the domestic players for their efforts in integrating the company's Fiber Laser sources with their machines together as 'Make in India' initiative. "They are introducing Lasers to the entry level market with economic machines and making the industry Laser-ready. These small industries shall gain experience and upgrade to high-end technology machines such as TRUMPF, which are more efficient with better price performance ratio," he states.

On Chinese peers

Of late, Chinese Laser companies have started to capture the Indian market with their low-cost Laser Machines. On whether it poses a competition, Pradeep Patil states, "Chinese Machine manufacturers attract new entrepreneurs who intend to enter the Laser business. Financial risks are covered due to low investment in initial years. However, change in dynamics is observed. Customers who started their business 2-3 years ago with Chinese machines, now aspire to enter the mainstream business by expanding their accessible markets. Mainstream market demands productivity, quality, repeatability, longevity and service support. This is where TRUMPF offers most lucrative value propositions that ensure sustainability in our customers' business. In fact, we look up to Chinese Machine manufacturers as complementors and not competitors," he says, summing up beautifully. 

TRUMPF's proven Laser technology in fuel injection mechanism, transmission, powertrain, exhaust system, Body in White (BIW) part production with mass volumes is slated to contribute majorly in the transition of India's automotive landscape to BS VI norms.

A WORLD LANGUAGE FOR MACHINES

The VDMA, in its strive to create a world language for factory automation, has teamed up with the OPC Foundation and its OPC UA technology, and is now developing market and industry-specific standards for the various domains in machine building, such as Robotics, Machine Vision, Machine Tools and many more.

Complex automation situation extended by an 'Easy to Integrate' ASENTICS machine vision system using the new interfacing via the standardized VDMA OPC UA Companion specification.

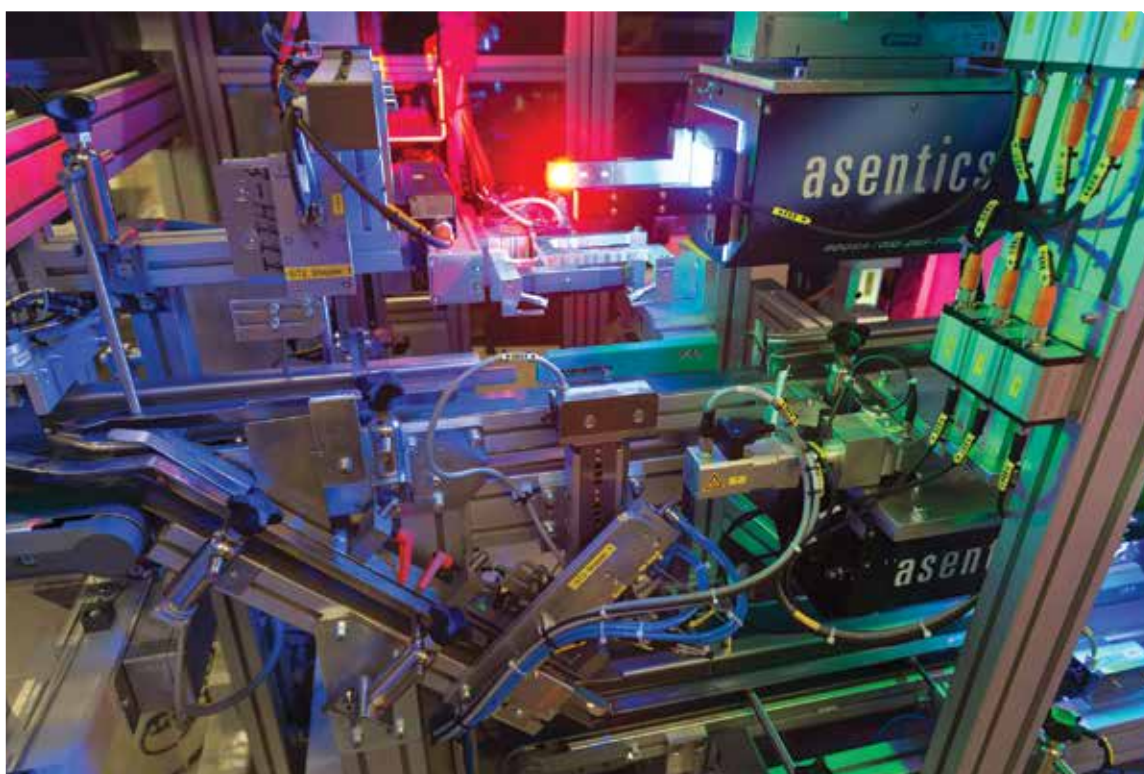

Source: ASENTICS GmbH & Co KG

DR HORST HEINOL-HEIKKINEN
Chairman
OPC Machine Vision
VDMA and
CEO, Managing Partner
ASENTICS GmbH &
Co KG
h.heinol-heikkinen@
asentics.de



Wouldn't it be great, if machines could communicate in a direct way with each other? This idea is at the core of the Industry 4.0 movement to create the smart factory of the future. This goal of reaching 'interoperability' is the new core competence that must distinguish our future products in a connected world of Industrial IoT - but even

more, the acting people and organizations involved.

The VDMA, Europe's biggest industrial association uniting more than 3,200 member companies from the area of mechanical engineering and machine building, has decided to drive the development of interoperability forward. In simple words: To create nothing less than a world language

for factory automation. To do this, it has teamed up with the OPC Foundation and its OPC UA technology and is now developing market and industry-specific standards for the many domains in machine building, such as Robotics, Machine Vision, Machine Tools and many more. These domain-specific standards are called 'Companion Specifications'.

Jin Shaa MACHINES



Portable Keyway Milling Machine with Auto Feed

Model No.	Keyway Capacity		Cutter dia	Shaft dia		Cross Shift
	Width	Length		Min	Max	
JSM 303	36mm	150mm	8-36mm	38mm	250mm	20mm
JSM 404	80mm	200mm	8-36mm	120mm	350mm	50mm



Portable Center Drilling Machine

Model No.	Shaft dia		Center Drill Cap
	Min	Max	
JSM 26	65mm	310mm	26mm
	Optional		
	310mm	650mm	

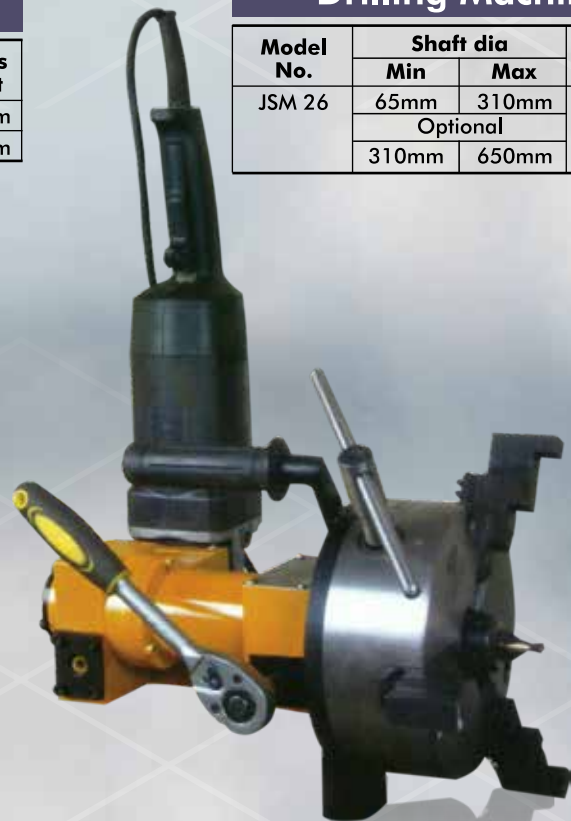

Jin Shaa Machines

No. 83/10, Rahul Apartment, Law College Road,
Erandwane, Deccan Gymkhana, Pune - 411004
Maharashtra, India

M: +91-8975768613

E: jinshaa@yahoo.com

www.jinshaamachines.com

To see our machine's video,
please scan QR-code

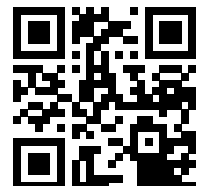

These specifications define the specifics needed within each domain. This article focuses on one such specification: the OPC UA Machine Vision Companion Specification.

OPC UA for Machine Vision

The acronym OPC UA stands for Open Platform Communications Unified Architecture. OPC UA is a vendor and platform independent machine-to-machine communication technology, which is officially recommended by the (German) Industry 4.0 initiative and other international consortiums, like the Industrial Internet Consortium (IIC), to implement Industry 4.0. The specification of OPC UA can be divided in two areas: The basis specification and companion specifications. The basis specification describes 'how' data can be transferred in an OPC UA manner and the companion specifications describe 'what' information and data are transferred. The OPC Foundation is responsible for the development of the basis specification. Sector-specific companion specifications are developed within working groups, usually organized by trade associations, like the VDMA as one key player in the Industry 4.0 initiative.

OPC Machine Vision Companion Specification

In January 2016, the VDMA Machine Vision Board decided to develop an OPC UA Companion Specification for

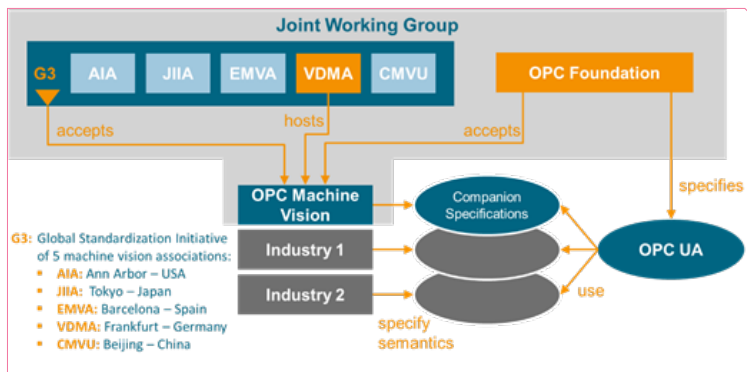

Figure 1: The OPC Machine Vision Joint Working Group coordinated by VDMA Machine Vision Initiative

Machine Vision. The work has been done within the joint working group, which consists by definition of the OPC Foundation and a host organization, which is the VDMA. To have broader reach, we decided to bring this important standardization work into our global standardization initiative called G3. This G3-cooperation consists of 5 machine vision associations acting around the world and fortifies our joint working as shown in Figure 1. The joint working group is coordinated by VDMA Machine Vision Initiative.

A generic information model

The OPC UA Companion Specification for Machine Vision (in short OPC Machine Vision) provides a generic information model for all vision systems - from simple vision sensors to complex inspection systems. Put simply, it defines the essence of any vision system that does not necessarily have to be a 'machine' vision system. OPC Machine Vision

is the accepted and officially supported OPC UA Companion Specification for vision systems by the OPC Foundation.

Part 1

Part 1 describes an abstraction of the generic vision system, i.e. a representation of a so called 'digital twin' of the system. It handles the management of recipes, configurations and results in a standardized way, whereas the contents stay vendor-specific and are treated as black boxes (Figure 2). It allows the control of a vision system in a generalized way, abstracting the necessary behavior via a state machine concept (Figure 3). A test implementation has already been successfully completed and was presented to a large audience of automotive engineering experts at a major event of the automotive industry in Germany dedicated to OPC UA. A hardware demonstrator is now being developed which will be showcased at major trade shows in Germany soon.

In future parts, the generic basic information model will shift to a more specific 'skill-based' information model. For this purpose, the proprietary input and output data black boxes will be broken down and substituted with standardized information structures and semantics. Following the idea of implementing information

This goal of reaching 'interoperability' is the new core competence that distinguishes our future products in a connected world of Industrial IoT - but even more, the acting people and organizations involved.

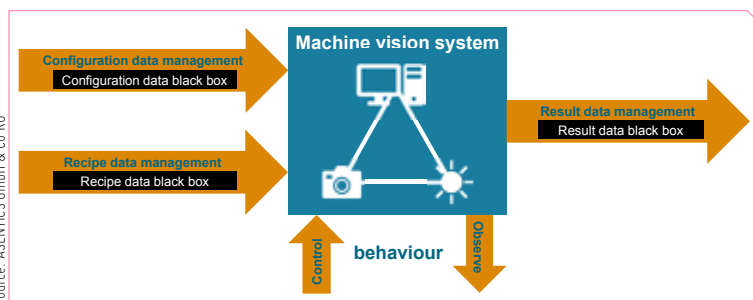

Figure 2: The 'black box' approach used by OPC Machine Vision

AccQrate

We build 'Q' for 'μ'



Complete Measuring Solutions and Services



Sales & Services

ACCURATE SALES & SERVICES PVT. LTD.

Gauge House, 67, Hadapsar Industrial Estate, Pune - 411 013

India. Tel.: +91-20-6603 9000/ 6603 9211

Fax: +91-20-2681 4234 | Email: sales@accuratesales.co.in

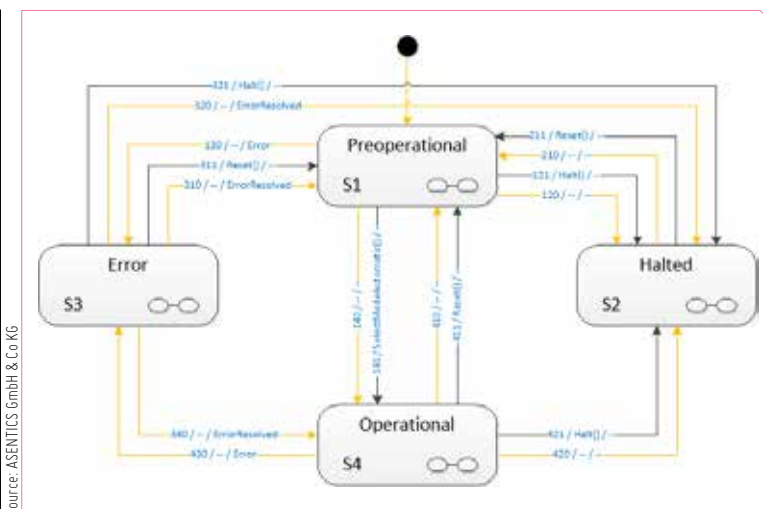

Source: ASENTICS GmbH & Co KG

Figure 3: The OPC Machine Vision Joint Working Group coordinated by VDMA Machine Vision Initiative

The scope is not only to complement or substitute existing interfaces between systems, but also to create so far non-existent horizontal and vertical integration abilities to communicate relevant data to other authorized process participants.

model structures derived from OPC UA DI (Device Integration, part 100) as OPC Robotics already did in Part 1 of the OPC Robotics companion specification. Thus, it ensures the idea of cross domain interoperability: so that machine vision systems can talk to robots and vice versa (and at a later stage to all kinds of devices).

OPC Robotics Companion Specification

The OPC UA Companion Specification for Robotics (in short OPC Robotics) provides a generic information model for robotic systems, independent of their characteristic or build-up. OPC Robotics is the accepted and officially supported OPC UA Companion Specification for robotic systems by the OPC Foundation. OPC Robotics Part 1 provides the rules for a standardized description of robotic systems to enable asset management and condition monitoring. It enables users to access industrial robots independent of location, brand or type of kinematics and read out important data (condition monitoring). The OPC Robotics information model, especially the identification data, is derived from OPC UA DI (Device Integration, part 100) which allows a generic

access and usability of data without specific knowledge of OPC Robotics.

Nine vendors with different kinds of robots integrated the information model to provide data for one HMI in the cloud and presented this at the Automatica trade fair 2018 in Munich. A touchscreen provided easy access to condition monitoring data of the nine robots participating in this demonstration. A simple touch on the touchscreen interface gave the user access to the condition monitoring data of the nine robots, all by different providers and located in geographically different locations. In a nutshell, the demonstrator enabled information about the different robots to be made available in a homogenized way, quite literally 'at your fingertips'. Based on the part 1, the information model will be extended in further parts to offer more information and features based on OPC UA. The plan for future parts contains messaging and alarming, remote control on several levels like loading programs, starting or stopping the robot or to influence the program flow for different product or process variants (as OPC Machine Vision, Part 1).

Our goal

The scope is not only to complement or substitute existing interfaces between systems, e.g. a vision system and a robot, and their adjacent process environments by using OPC UA, but rather to create so far non-existent horizontal and vertical integration abilities to communicate relevant data to other authorized process participants, e.g. right up to the IT enterprise level. It is possible to have a gradual phase-in of OPC Machine Vision and OPC Robotics with other coexisting interfaces. The benefits are a shorter time to market by a simplified integration, a generic applicability and scalability and an improved customer perception due to defined and consistent semantics. Specific example: Both Companion Specifications enable their real system representatives (Vision System or Robot) to seamlessly communicate with the whole factory and beyond.

This begs the question: "Has image processing thus finally arrived in automation technology and become an integral part of it?" The answer is: "Definitely YES!" The previous standards (keyword automation pyramid) left little room for the powerful information image processing systems - this has now fundamentally changed.

Image processing systems were considered to be 'glorified light cabinets' in these standards which delivered a result of 0 or 1 (good or bad). Any additionally generated information - in the sense of interfaces, e.g. to an MES - was actually generated outside existing standards. Now Industrial Machine Vision can play all cards with its well-defined information model and can do so on the basis of suitable and standardized interfaces - OPC UA. 

VERICUT®

CNC Machine Simulation Software

CNC Machine
Simulation,
Verification, &
Optimization Software

```
...1  
...49G91G28Z0.M9  
...OG28X0.Y0.A0.  
...760M01  
...TOOL - 4 DIA. OFF. - 4 LEN  
... (Center drill .500 holes -  
...M9520M6  
...M9525T5  
...M9530G0G90A0.S5000M3  
...M9535G54X-4.8Y-2.  
...M9540G43H4Z1.M8  
...M9550G98G81Z-2.77R-2.42F100.  
...M9560X0.Y-2.  
...M9570X4.8753Y-2.  
...M9580Y2.  
...M9590X0.Y2.  
...M9600X-4.8Y2.  
...M9610X0.Y0.Z-2.02R-1.67  
...M9620G80  
...M9630M5  
...M9640G91G28Z0.M9  
...M9650X0.Y0.A0.  
...M9660 - 5 LEN.
```

**CRASH
DETECTED!**

**SAVE TIME • SAVE MONEY
SAVE YOUR MACHINES**

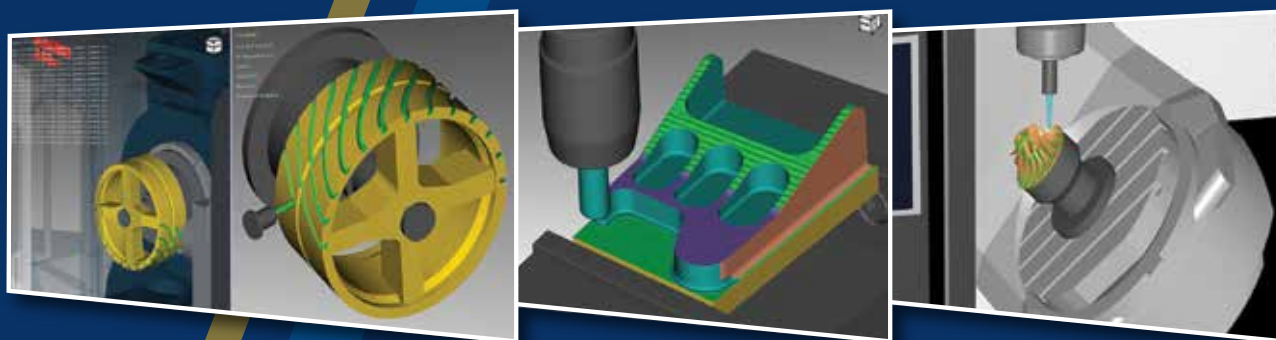

Right the first time. Every time.

CGTech India Software Solutions Pvt. Ltd.,
#38, 1st Main, 3rd Cross, Malagala
New Outer Ring Road
Bangalore 560 091
Office: 080 2318 6981; info.india@cgtech.com

CGTECH.co.in

DOING MORE WITH LESS

This space is dedicated to SMEs and their resilient spirit to rise despite the blocks they encounter on their way to success. This time's spotlight is on Arihant Honing & Finishing Technology (i) Pvt Ltd, which is the perfect embodiment of all that takes to succeed and thrive.

Arihant Honing & Finishing Technology (i)'s team that diligently contributes to achieving the company's vision.



Source: Arihant Honing & Finishing Technology (i)

With majority as SMEs in the Indian manufacturing industry, it should ideally be easy for the smaller and medium manufacturing units, rightly termed as the 'engines of growth', to gain access to the resources they need. However, the ground reality is quite contrary. SMEs are still grappling with even basic issues such as procuring formal credit and skilled personnel to catapult themselves ahead in their path of progress. Arihant Honing & Finishing Technology (i) Pvt Ltd is an SME that has overcome the quintessential smaller unit-hurdles that paved its way to the successful position it currently enjoys. The company today is reckoned as one of the prime manufacturers and suppliers of a wide spectrum of Honing and Superfinishing machines for

Automobile, Oil & Gas, Aerospace and Bearing industries. The machines comprise Horizontal Tube honing machines, Precision Vertical honing machines, Special Superfinishing machines, Throughfeed Finishing machines, Bearing Races, Roller Finishing machines, Flat Finishing machines etc. Honing and Finishing are high-precision processes designed to handle the most demanding manufacturing challenges and, hence, are relatively expensive. Most of the companies in India import these machines in concern of quality. Sameer S Kartha, Director, Arihant Honing & Finishing Technology (i) had been working for US- and German-based machine tools companies for 16 years. That's when he recognized an opportunity to indigenously make such machines at

international quality standards and offer at a lower cost to cater to the needs of the Indian companies. "The cost at which Indian customers bought these machines was too high. That prompted us to start a manufacturing company under the 'Make in India' scheme," he shares. Under the guidance of the company's experienced Technical Director and with the support from the team, Arihant succeeded in delivering equally efficient machines at 40-50 percent lesser cost than the imported ones. Now the company is receiving orders from countries like Germany and the US, where most of the competitor companies head their offices. "Since inception, Arihant has been efficiently meeting the quality requirements of our valuable clients while keeping

POONAM PEDNEKAR
Chief Copy Editor
Magic Wand Media Inc
poonam.pednekar@
magicwandmedia.in



Latest MACHINE TOOL Solutions



22 23 24 25

APRIL 2020

Bombay Exhibition Center,
Goregaon (E), Mumbai, India

BOOK
NOW

Grab a chance to showcase your latest machine tool technologies at India's largest die mould exhibition.



ORGANISED BY:

TAGMA
INDIA

TOOL AND GAUGE
MANUFACTURERS
ASSOCIATION - INDIA

A-33, Nand Jyot Industrial Estate, Safed Pool,
Andheri - Kurla Road, Mumbai - 400 072
Tel.: +91 22 28526876, 28508976, 28503273, +91-9653427396
E-mail : tagma.mumbai@tagmaindia.org,
tagma.diemould@tagmaindia.org,

www.diemouldindia.org



Source: Arihant Honing & Finishing Technology (i)

“We are planning to have an in-house facility for machining for which we need machines such as VMCs, Turning Centers, Surface Grinders, and Wire cutting machines.”

Sameer S Kartha
Director
Arihant Honing & Finishing Technology (i)

in mind international quality standards and norms. We are committed towards delivering a range of machines and equipment that exhibit efficient performance, operational stability, designing impeccability, and minimal maintenance requirements,” stresses Kartha. The other two Directors are Dhanalakshmi Sameer Kartha and Melwin Joseph Dcunha. All are professionals having years of experience that has helped Arihant reach the next level of business.

Overcoming challenges

Initial hiccups: One of the key challenges faced by Arihant during the initial stages was that its proposal would get rejected by the customers who feared that the company’s machines would not render the same quality and efficiency as the imported machines. However, Arihant proved its efficiency in its first order itself from an international company and at a much lower price.

“It was difficult to convince customers that we could produce the same quality machines with 40 percent lesser cost, and which

can be import substitute. We used to travel extensively all over India to visit prospective customers and offer technical presentations. Then we made some prototype machines and invited them to visit us and witness the process. It took us lot of in-house preparations. Finally, we could prove to them and gain some orders,” he adds.

Financial constraints: To compete with the infrastructure and marketing strategies of international players that have offices in India, Arihant requires a solid financial backup. “The continuing challenge we face as an SME is raising of capital for upgrading our operational activities for establishing in-house facilities for which we have approached several financial institutions. The response from them has been not favorable as of yet,” shares Kartha.

“We have open orders from the customers and are under ‘Make in India’ and MSME registered, still banks have shown no interest to support us. In our case, the order in hand is the guarantee that we can pay the loan back. There should be some scheme for financing small companies taking the order as a guarantee for repayment,” he adds.

“However, a few companies trusted and supported us and placed orders with us. Now, we have also begun to export and are trying for a collaboration with a German company for technical upgradation,” he adds. Meanwhile, the management is hopeful with the policies of ‘Make in India’ and is working towards the same.

Dearth of skilled labor:

The skilled labor shortage is one of the biggest challenges manufacturers face. “Getting

skilled engineers and workers is a major issue. Newly graduated engineers do not have even basic engineering knowledge. The workers are also unskilled. To address this, we now conduct frequent training sessions on quality parameters, geometrical tolerances, quality mentality etc. We have also made all our employees responsible for quality and even have a QA cell. Employees can suggest improvization and good suggestions get rewarded,” shares Kartha.

Reaching higher

Arihant Honing & Finishing Technology is now looking to export its machines to the US and Germany. “Accuracy and consistency are important aspects when one exports. We have a tie-up with a company to sell our machines in Europe. We also outsource many of our machine parts. Since we are facing issues on quality and on-time delivery, we plan to have an in-house facility for machining for which we need machines such as VMCs, Turning Centers, Surface grinders and Wire cutting machines,” informs Kartha.

The company’s German counterpart is helping it improve its quality to German standards. “They study our machines, run it, and guide us as to which area needs to be improved. This will help us to sell less expensive machines with better quality,” he concludes. 

Machine 1200 TF NC



Source: Arihant Honing & Finishing Technology (i)

Honing and Finishing are high-precision processes designed to handle the most demanding manufacturing challenges and, hence, are relatively expensive. Most of the companies in India import these machines in concern of quality.

Driving Manufacturing Excellence through Automation

SYMPOSIUM ON SMART AUTOMATION

21 - 22 November 2019, BIEC, Bangalore



FOCUS AREAS

- Automation for Small & Large Batch production
- Material Handling
- Packaging Automation
- Smart Sensing
- IT in discrete manufacturing

PLANT VISITS (20 November 2019)

Leading manufacturing companies open their doors to participants on 20 November 2019 (a day prior to the event) to showcase latest developments and practical implementations of Automation on their shop floor.



WHO SHOULD PARTICIPATE

CEOs, Top Management, Senior Executives, Practicing engineers, Industry consultants and R&D Specialists from Automotive, Auto components, Aerospace, Consumer durables, Machine Tools, Tool rooms, Defence & Railway units, General Engg. and other manufacturing industries.

Organised by



www.imtma.in

INDIAN MACHINE TOOL MANUFACTURERS' ASSOCIATION

@ Bangalore International Exhibition Centre (BIEC) 10th Mile, Tumkur Road, Madavara Post, Bangalore - 562 123 Fax : 080 6624 6661

For details please contact : Abhishek (abhishek@imtma.in)

Tel: 080-66246829 / 6805, Mobile : +91 9886611007

LIVEWORX 2019: MECCA FOR DIGITAL TRANSFORMATION

Hosted in the bustling Innovation District of Boston, this edition of PTC's flagship event, LiveWorx witnessed a conglomeration of 6,500 attendees from all parts of the globe. Housed in the high-tech Boston Convention & Exhibition Center (BCEC), the conference ran for four days packed with interactive workshops, cutting-edge demos and latest innovations making digital transformation a reality for the manufacturing fraternity.

Jim Heppelmann, PTC, President & CEO, said that a unique combination of capabilities from CAD, PLM, IoT, and AR is required to drive innovation across enterprises' products, processes, and people.

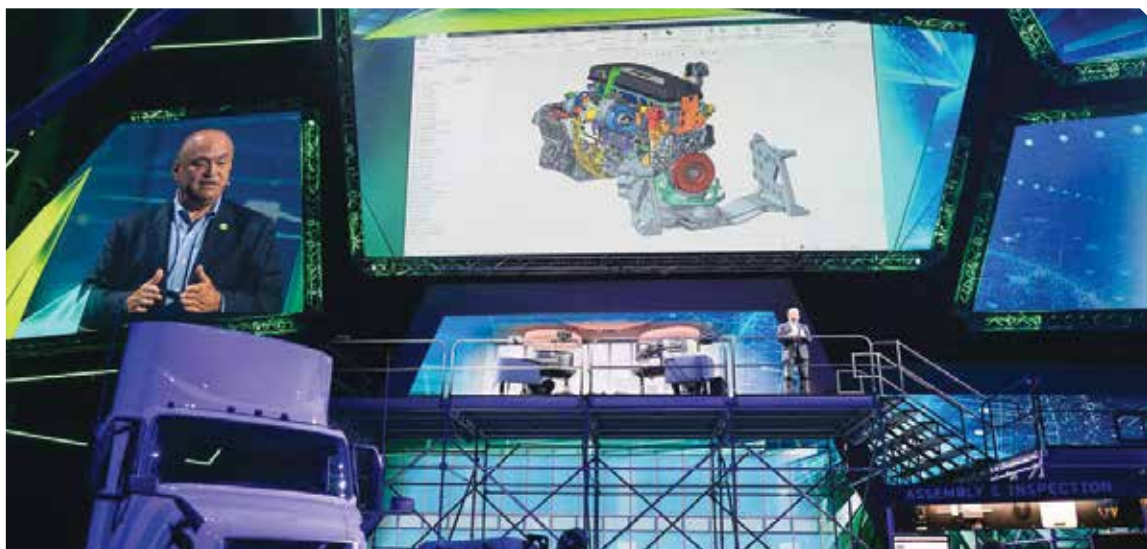

Source: PTC

A plethora of disruptive technologies and topics including augmented reality (AR) and virtual reality (VR), the industrial internet of things (IIoT), Industry 4.0, digital engineering, artificial intelligence (AI), and robotics were presented at this mammoth digital transformation meet. Kickstarting the event, Jim Heppelmann, President

& CEO, PTC, said, "There is a growing awareness that disruptive innovation happens at the intersection of multiple advanced technologies such as IoT, AR, AI, and Digital Twin. Powered by these complementary technologies, companies now have the tools they need to completely transform the way they generate value through improved efficiency

and productivity across products, processes, and people."

Success speaks volumes

To make understand how these above ideas are being put into practice for driving digital transformation and innovation across the industrial enterprise, Heppelmann shared insightful customer success stories.

SOU MI MITRA
Editor-in-Chief
Modern Manufacturing
India
soumi.mitra@
magicwandmedia.in



Source: Magic Wand Media

The wooden table placed in PTC's headquarter in Boston is made of a 200 year old wrecked ship. The interior is as impressive as the building from outside.



Source: Magic Wand Media

Oshkosh Defense's JTLV was displayed to demonstrate collaboration between PTC and Oshkosh for AR and industrial IoT.



Source: PTC

Michelle McKenna-Doyle, Senior Vice President & CIO, National Football League, pointed that large-scale collaboration and microservices facilitate enterprises to collaborate.



Source: PTC

The Xtropolis show floor was compartmentalized according to industry tracks such as 'Field,' 'Office,' and 'Factory' to help attendees find the demonstrations, workshops, and hands-on experiences relevant to them in one place.

In order to realize potential efficiency savings, Volvo Group needed to reimagine the design of its SuperTruck, a state-of-the-art tractor + trailer combination. The weight of the engine mount bracket needed to be reduced without compromising the performance of the vehicle. With PTC, Volvo created business value from engineering to manufacturing - realizing the digital thread, from real-time simulations in CAD (Creo) via product variability management in PLM Windchill to delivering AR-based operator work instructions through Vuforia. Sharing his experience, Bertrand Felix, Senior Research and Technology Development Manager, Volvo Group, said, "PTC brings in a strong knowledge and experience on CAD-PLM and also stands as one of the world's leading experts on IoT and AR. This is a huge differentiation: the digital continuity and connection with our own systems is possible only with the PTC value chain." Similarly, Dr Maria Wilson, Global Leader of Data Driven Advantage, Howden, shared the digital twin strategy for their innovative product, a diaphragm



Source: Magic Wand Media

Panel Discussion featuring Senior Members from Aggrekko, Fujitsu, Global Foundries, and Howden highlighted on ways to bring digital technology such as AR to the enterprise.

compressor, used in hydrogen production for fuel cell electric vehicles. She explained how the company uses Vuforia Studio to create AR content based on IoT data from ThingWorx and calculate business cases for AR.

Changing trends

Michelle McKenna-Doyle, Senior Vice-President & CIO, National Football League (NFL), spoke on the four key trends that are changing the way teams work together: location independence; new ways of measuring employees in real time; a new level of intense, large-scale collaboration; and microservices that enable enterprises to collaborate. Pointing to the NFL's distributed data centers that manage NFL games' activities and communications remotely, she spoke on how NFL measures athlete performance, such as speed and acceleration, through the use of sensors placed on the athletes' shoulder pads.

Collaboration is crucial

Acknowledging the importance of choosing key strategic partners in digital transformation, PTC made several announcements in terms of alliances, investments,



Source: Magic Wand Media

The 200,000 sq ft Xtropolis showcased some of the most advanced applications of digital transformation available for the industrial enterprise.

and a strategic acquisition such as: **New AR Acquisition:** PTC acquired TWNKLS, a Netherlands-based company that develops tailor-made AR applications, experiences and services to solve specific challenges faced by enterprise companies.

Technology Partner Investment: PTC has invested in and partnered with Matterport, a company that offers immersive 3D technology and spatial capture solutions.

2019 Microsoft Partner of the Year: PTC has been recognized as the 2019 Microsoft Partner of the Year in two categories: 'Manufacturing and Resources' and 'Mixed Reality', and finalist in the 'Internet of Things (IoT)' category.

Rockwell and PTC's collaborative offering, FactoryTalk InnovationSuite, allows industrial enterprises to optimize factory operations and enhance worker productivity by leveraging powerful data and insights.

Key takeaways

It can be concluded that manufacturing companies must use what they have, adopt the best of what's new, and apply that to drive innovation across their products, processes, and people to succeed in digital transformation and innovation.

To be part of the next edition of LiveWorx, save the dates from June 08-11, 2020; the show will be co-located with a new event from Rockwell Automation at BCEC. 

PTC has been recognized as the 2019 Microsoft Partner of the Year in two categories: 'Manufacturing and Resources' and 'Mixed Reality'.

Top AR Tips from Experts

- An innovation journey is non-linear. We need to embark on it and take the zigzags to arrive at the value grounds
- In order to drive value from AR, one must have very clear cases about how it supports the enterprise digital journey
- Understand the business problem you are trying to solve and measure as you go
- Collaborate and build cases for AR across your value chain. No one is alone on this journey.

DMTX 2019: JOINING THE DOTS

Organized by Indian Machine Tool Manufacturers' Association (IMTMA), the third edition of Delhi Machine Tool Expo (DMTX 2019) effectively pulled in an impressive number of delegates and visitors from Tier 2 and Tier 3 cities from the nearby states of Uttar Pradesh, Uttarakhand, Haryana, Himachal Pradesh, Rajasthan, Punjab, etc. at India Expo Centre & Mart, Greater Noida from August 08 - 11, 2019.

(L-R): Indradev Babu, Vice President, IMTMA; V Anbu, Director General & CEO, IMTMA; Sukriti Likhi, Hon'ble Joint Secretary, Department of Heavy Industry, Government of India; Shri Arvind Ganpat Sawant, Hon'ble Minister of Heavy Industry and Public Enterprises; and P Ramadas, President, IMTMA; lighting the lamp at the inauguration ceremony of DMTX 2019.



Source: Magic Wand Media

The show succeeded in its attempt to be a window on the global market and present state-of-the-art manufacturing technologies in metal cutting and metal forming. Additionally, Sheet metal forming machines, CNC machines, and Metrology were prominent highlights.

A befitting start

The event got off to a special start with industry veterans and field experts taking part in the opening day festivities. The traditional lamp lighting ceremony was graced by the Chief Guest Shri Arvind Ganpat Sawant, Hon'ble Minister of Heavy Industry and Public Enterprises, Government of India; along with Smt Sukriti Likhi, Hon'ble Joint Secretary, Department of Heavy Industry, Government of India.

Also present were P Ramadas, President, IMTMA; Indradev Babu, Vice President, IMTMA; V Anbu, Director General & CEO, IMTMA; and other eminent dignitaries from the industry and the Government.

With regard to the 'Make in India' initiative, Shri Sawant said, "Income tax has been reduced to 25 percent for the companies with a turnover below ₹400 crore."

Spotlight on SMEs

In his welcome note, Anbu emphasized on the importance of organizing regional expos and highlighted IMTMA's pursuit to strengthen SMEs through such shows. "If the country needs to progress in the manufacturing sector then we need to empower SMEs as they are the backbone of manufacturing in India. Regional

machine tool expos are held by IMTMA to take technological advancements to the doorsteps of SMEs of particularly Tier 2, Tier 3 and Tier 4 industry segments," he said.

Seconding his views, Ramadas added, "Our exhibitions have been able to create a win-win situation for both Indian and global machine tool builders. The Delhi Machine Tool Expo is one such initiative which has been taking a lead in bringing technology to the doorsteps of SMEs in the northern region of the country."

Innovation on the showcase

DMTX covers a wide spectrum of metalworking industry. Hence, the product palette provided total delight to visitors who had come expecting the same. Jyoti CNC Automation Ltd showcased a selective blend of five machines

ARUNIMA NATH
Correspondent
Magic Wand Media
arunima.nath@
magicwandmedia.in



CHENNAI TM
**MACHINE
TOOL EXPO** 2019

26 - 29 September 2019
Chennai Trade Centre, Chennai

Biggest show in the region to connect
with best manufacturing industries

Delivered by the organiser of **IMTEX** 

SPECIAL PAVILIONS

METROLOGY EXPO
Exhibition for Metrology, Testing Instrument and Equipment

WELDEXPO
Exhibition for Welding, Cutting & Joining

AME

Factory of the
FUTURE
An Expo on Industry 4.0



Organiser



Indian Machine Tool
Manufacturers' Association

Media Partner

M MODERN
MANUFACTURING
INDIA



www.mtx.co.in



Source: Magic Wand Media

“Manufacturing companies should not only strengthen themselves, but should also make sufficient profit to generate employment. Target should be to learn to produce innovative products so that we can be globally competitive.”

Shri Arvind Ganpat Sawant
Hon'ble Minister of Heavy Industry and Public Enterprises
Government of India

out of its exhaustive range – DX 170 nvu in Turning Center, Tachyon 7 in High Speed Drill Tap Center, VMC 1580 in VMC Performance Large Series, VTL 500 in Heavy Duty Vertical Turning Lathe and HX 500 in Horizontal Machining Center. Additionally, the company offered the experience of the world of Industry 4.0 through live demonstration of its new offering – 7th SENSE.

Electropneumatics & Hydraulics (I) provided live demonstration of its two machines – 5 Axes CNC Tube Bender 38CNC5X3-Hybrid and 35T Electric



Source: Magic Wand Media

“We have been participating in many regional exhibitions, which are highly profitable for us. This edition of DMTX drew in serious buyers and its move to Noida improved its accessibility. The sentiment in the manufacturing industry may be a bit slow now, but the future surely stands bright.”

Kabir Bhogilal
CXO - Corporate Strategy
Batliboi Ltd



Source: Magic Wand Media

“DMTX has definitely evolved over time. We displayed machinery with more automation and the response was amazing. We generated 20 leads on the first day itself and all were quality prospects.”

K Soundhar Rajhan
Director, Operations
Business Head - MTD, Foundry & ATC
Lakshmi Machine Works Ltd

Servo Mechanical Press with a tonnage capacity of 35T and a C-Frame construction.

K Ganapathi Subramanian, Vice President – Marketing & Sales, Gedee Weiler Pvt Ltd, shared, “DMTX is highly instrumental to help us reach out to a big number of customers in Delhi NCR, especially the SMEs who may not have the opportunity to visit us at bigger shows like IMTEX.” The company displayed its latest Turnmill center that caters to various industrial segments that involve finishing components and need turning and drilling / milling in one setting.



Source: Magic Wand Media

“Through DMTX we mainly aimed to gain exposure to the North Indian market. We got satisfactory footfalls from Noida, and the Gurgaon cluster and connected with relevant manufacturing companies of the region.”

Meetal Mukherjee
Director
HYDAX Hydraulics Pvt Ltd



Source: Magic Wand Media

“This was our second time at DMTX. The market being slow, this is the time people look for new technologies. We received quality visitors. The venue was perfect with great infrastructure and logistics.”

Gaurav Sarup
Managing Director
Marshall Machines Ltd

Meanwhile, FARO Business Technologies India Pvt Ltd, presented its Metrology Solutions including Vantage^s Laser Tracker for large-scale 3D measurement that boasts of superior accuracy, exceptional portability and outstanding ruggedness.

Yet another regional fair lined up

After a highly successful edition of DMTX, IMTMA is all set to have the ball rolling in the South of India now with Chennai Machine Tool Expo (CMTX) 2019, which is scheduled to take place on September 26 – 29, 2019. 



Source: Magic Wand Media

“IMTMA’s exhibitions have a tradition of huge success. DMTX, in its initiative to meet the needs of end users, has been highly influential in offering relevant technologies and solutions. It spreads awareness on technological fundamentals.”

Vijay Zaritaklikar
National Sales Manager
UCAM Pvt Ltd

If the country needs to progress in the manufacturing sector then we need to empower SMEs as they are the backbone of manufacturing in India.



Make it possible



International Forming Technology Exhibition



International Exhibition of Dies & Moulds, Forming Tools,
Machine Accessories, Metrology and CAD / CAM

23 - 28 January 2020, Bangalore, India

Organiser



Indian Machine Tool
Manufacturers' Association

Venue



www.imtex.in

TOWARDS SHOP FLOOR SUCCESS

Organized by Indian Machine Tool Manufacturers' Association (IMTMA), the 13th edition of National Productivity Summit (NPS 2019), held on August 20 - 21, 2019 at Bangalore International Exhibition Centre (BIEC), Bengaluru, pointed out umpteen production bottlenecks in the Indian manufacturing and demonstrated effective practices to attain productivity gains. An overview...

The winners of Productivity Champions 2019 Award with the jury and IMTMA titans.



Source: Magic Wand Media

Every year, IMTMA organizes National Productivity Summit with the view to showcase best practices in manufacturing and help the industry enhance its productivity and competitiveness. Through insightful keynotes, live case study presentations, plant visits, success stories, the summit highlights the need to embrace an integrated approach to increase manufacturing productivity, and the ways to make it possible with efficient team, processes and technology. This year, however, NPS stood out to be a tad different than its predecessors; the composition of the audience which used to be 60 percent from the auto industry was this year 75 percent from the non-auto industry. Many hailed this

change as progress and a good sign that other industries involving metalworking have started to participate in the yearly summit.

Bhaskar Bhat, Managing Director, Titan Company Ltd, did the honors of inaugurating NPS 2019. Also present were P Ramadas, President, IMTMA; Indradev Babu, Vice President, IMTMA; and V Anbu, Director General & CEO, IMTMA; and Shailesh Sheth, Past President, IMTMA.

Expert take

Giving the summit a befitting start, Bhat, in his opening address 'Impact of Productivity on India's Manufacturing Competitiveness', focused on the challenges the Indian manufacturing industry currently encounters. The

challenges, he stated, are primarily centered on the additional cess levied on the manufacturing fraternity, high logistics cost, the skill mismatch, and the spending on R&D. He emphasised on the strong implementation of Automation, Digitization, Industry 4.0 and investment into R&D to improve India's productivity in all sectors.

Ramadas, in his welcome address, stated, "This summit would achieve its objective only if you take back the learnings from here for the successful implementation and application in your individual organizations. This gathering is unique where the manufacturers and users are sitting shoulder to shoulder to learn the ways to achieve quality and be updated about new facets of manufacturing.

Source: Team MMI

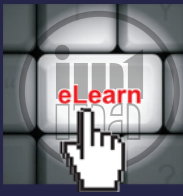

Learn any course, anytime
@ your pace



Enhance professional capability

e-learning

on

Manufacturing Technologies

Contact : 9535162810
e-mail : kng@imtmaelearn.in



Get started... Now...
Log on to...
www.imtmaelearn.in



IMTMA Technology Centre
Indian Machine Tool Manufacturers' Association
www.imtmatraining.in | www.imtmaelearn.in

For further details and registration, please contact:
Indian Machine Tool Manufacturers' Association
BIEC, 10th Mile, Madavara Post, Tumkur Road, Bangalore - 23



P Ramadas, President, IMTMA and Bhaskar Bhat, Managing Director, Titan Company Ltd, at the inaugural ceremony.

Source: IMTMA



TV Mohandas Pai, Chairman, Manipal Global Education, graced a special session held for CEOs and delivered his address on 'Winning in the Digital World'.

Source: IMTMA



Around 60 CEOs from the Indian manufacturing fraternity attended the CEO Meet.

Source: IMTMA

Going forward, I am sure we will reach much higher levels of manufacturing."

Enriching keynotes

Keynotes make for the summit's substantial part where industry experts impart their knowledgeable and experienced views on a gamut of topics. This year's edition featured three keynote speakers. G Parthipan, CEO, Rane TRW Steering Systems, spoke on 'Adopting modern manufacturing technology to enhance productivity'; Dr Babu Padmanabhan, Managing Director and Chief Knowledge Officer, Steer Engineering, presented his take on 'Innovation as a powerful tool to enhance productivity'; and 'Thriving in the era of disruption - How organizations stay afloat' was presented by Sandeep Kumar Maini, Chairman, Maini Group.

TV Mohandas Pai, Chairman, Manipal Global Education, graced a special session held for CEOs and delivered his address on 'Winning in the Digital World'. The session convened 60 CEOs from the Indian manufacturing fraternity.

Case studies and plant visits

This year, over 150 case studies made their way to the summit from which 11 were shortlisted and presented live at the event. These were from BHEL,

Godrej & Boyce Manufacturing, Carborundum Universal, Bosch, Rane TRW Steering Systems, SAAB Engineering, Bharat Heavy Electricals Ltd and Mahindra & Mahindra, Gala Precision Engineering, Khutale Engineering and UCAM. All these companies contested for the IMTMA-ACE Micromatic Productivity Championship Awards 2019.

"We need to constantly focus on bridging the knowledge that adds skills in the industry and to make the industry technologically more contemporary. In the last two days, we have witnessed several examples of manufacturing excellence to realize the vision of manufacturing contributing 25 percent of our GDP from the current 16 percent," said Sheth.

Pre-summit plant visits were organized to Ashok Leyland, TVS Motor Company, Honda Motorcycle & Scooter India, Volvo Trucks, Dynamatic Technologies, and Volvo Construction Equipment, which proved to be an ideal opportunity to closely witness some of the best productivity practices being put into action.

Planning ahead

NPS has always been well received by the industry players keen to gain insight into the best practices adopted by their peers and implement in their own manufacturing processes. To help them mark their calendar well in advance, IMTMA has already scheduled the 14th edition of NPS in August 2020 at Pune.

The next National Productivity Summit is to be held at Pune in August 2020. Calendars be marked.

The IMTMA-ACE Micromatic Productivity Championship Awards 2019

Prize	Winner	Case Study
First	Mahindra & Mahindra	Reduction of specific Carbon footprint by using Waste to Wealth, TPM and Industry 4.0 concept in the utility management area
Second	Bosch Ltd	Innovative approach using Mould flow analysis for productivity improvement in Common Rail Pump Housing
Third	Godrej & Boyce Manufacturing	Use of Industry 4.0 in manufacturing for resource utilisation and reducing conversion cost
SME Productivity Award 2019	Khutale Engineering	Learn and Green approach to layout planning

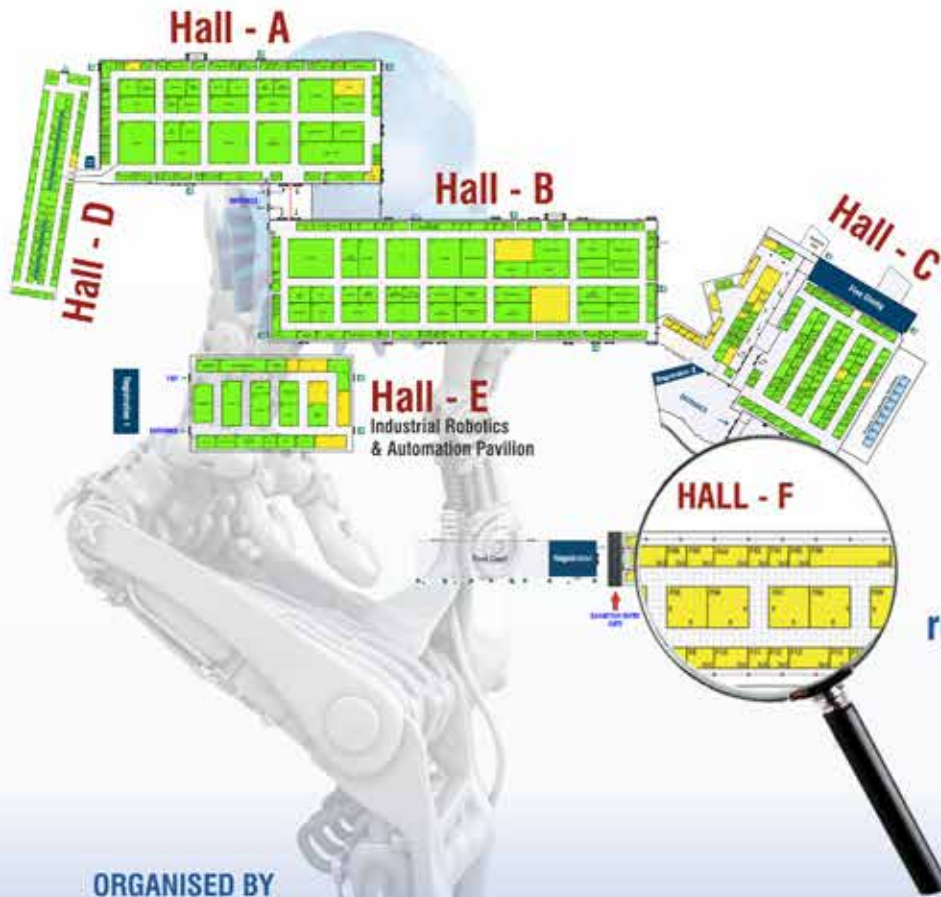

New Hall F

to meet the
 overwhelming
 requirements of manufacturers
 of **METAL WORKING
 EQUIPMENT**

for Space Booking
Log on www.acmee.in

ORGANISED BY



TITLE SPONSOR



PLATINUM SPONSORS



DIAMOND SPONSORS

POWERED BY

GOLD SPONSORS



SILVER SPONSORS



Vibration Sensors and Accelerometers

MARPOSS India Pvt Ltd
 T: +91 (124) 4735700
 E: sales@in.marposs.com
 www.marposs.com

Everything is Vibration

ARTIS offers sensors in the measurement range between 10 Hz and 5 kHz for acceleration measurement on one to three axes.

Measurement of vibrations and accelerations plays an important role in process monitoring on machine tools. Vibration measurements are used in different ways for the safeguarding and stabilization of processes: as signals from the machine control or from external sensors. Vibration measurement is made as close to the process as possible. Sensors are integrated directly into the spindle or placed on the workpiece holder.

Measuring acceleration

Acceleration can be measured with a sensor integrated into the spindle or with external sensors placed in the machine. A transducer then converts the values for the process monitoring system into information about the vibration speed. ARTIS offers sensors in the measurement range between 10 Hz and 5 kHz for acceleration measurement on one to three axes.

Acoustic emission, a special form of vibration, is measured with external sensors and transmitted over a separate fieldbus. The sensors for acoustic emission cover the measurement range of 10 to 250 kHz.

Collision monitoring

Acceleration sensors can be used for collision monitoring. When tool and workpiece collide, which the sensor detects from the sudden change in material vibration, the machine shuts off immediately. Here, the measurement means a gain of approx. 200 milliseconds until the machine's overload protection would take hold. It is exactly during this time after a collision that serious damage results, because the machine at first "reacts" to resistance with increased power.

Optimization in the ongoing process

Vibration measurement is also used for process optimization, such as in gear cutting with profile milling cutters. Tool wear here depends on the vibration speed of the tool. Experiments show that an increase in cutting speed of only 10 percent results in a significant decrease in the vibration speed. So here, optimization can be achieved by simple means. Additionally, with Adaptive Control, the vibration behavior at the milling head can be optimized in the ongoing process.

SUBSCRIBE THE PRINT MAGAZINE AND GET THE DIGITAL FREE!



www.mmindia.co.in/magazine_issues

Yes, I wish to subscribe to
MODERN MANUFACTURING INDIA

1 Year	₹ 750
2 Years	₹ 1200

PERSONAL DETAILS

Company _____
 Name _____
 Department _____ Designation _____
 Company Address _____

 City & Pin Code _____ Country _____
 E-mail _____ Contact No. _____
 Industry _____

SUBSCRIPTION PAYMENT DETAILS

Please find enclosed cheque / DD No.: _____
 Drawn on (Name of bank & branch): _____
 _____ Dated _____
 For Rs. _____ Rupees in words _____

Favouring INDIAN MACHINE TOOL MANUFACTURERS' ASSOCIATION

IMTMA, Bangalore International Exhibition Centre (BIEC), 10th Mile, Tumkur Road, Madavara post, Bangalore - 562123
 Tel: 080 - 66246617 imtma@imtma.in

Sources & Terms of Supply: Orders can be placed directly with the publisher. No claims for the supply of back copies or reimbursement of subscription fees can be entertained for non-delivery of the magazine for reasons beyond the publisher's control.



Debuts at EMO

The CHIRON Group is appearing at EMO with a lot of debuts: new machining centers, software and automation solutions.

CHIRON Group
T: +49 (0) 7461 940 3822
E: rainer.schopp@chiron.de
www.chiron.de

EMO CHIRON Group
Hannover Hall & Stand:
12 / C06



Source: CHIRON Group

Autonomous machining of complex workpieces — at the EMO, CHIRON is combining the new FZ 16 S five axis with VariocellPallet pallet automation for the first time.



Source: CHIRON Group

MT 733 one plus: Complete machining of complex components and difficult-to-cut materials.

CHIRON: new variants of the 16 series and DZ 25 P five axis

The new FZ 16 S five-axis combined with VariocellPallet pallet automation is aimed at machining small batch sizes and complex workpieces autonomously. The new DZ 16 W five-axis will be presented live in action in Hannover.

The CHIRON DZ 25 P five axis is designed for productive machining of large components in the automotive industry and aviation. With a spindle distance of 800 mm, the DZ 25 P five axis is predestined for double-spindle machining of aluminum structural components.

STAMA MT 733 one plus – complete machining for complex workpieces

Like all models of the MT 733 series, it has a gantry design: this allows the machining process to gain a significant amount of stability on a thermal, mechanical and static level. The Galaxie® drive system in the B-axis bolsters



Source: CHIRON Group

The SmartLine modules ensure process reliability, higher productivity and production optimization.

this effect with its extreme power density, stiffness and positioning precision.

Vertical turning from SCHERER

The VDZ 320 is a multi-functional vertical pickup turning machining center. The series can be precisely tailored to the customer's requirements. Options include another milling spindle and special modules for ball turning, bearing track milling and hobbing.

CMS presents automation solutions that can be retrofitted

Retrofit specialist CMS is showing how an outdated machining center can be enhanced by a modern automation solution and how this can significantly improve productivity.

SmartLine software portfolio extended

This year, the CHIRON Group is extending its SmartLine program with ConditionLine and ProtectLine. The software modules can be implemented individually or together. ConditionLine allows precise planning of maintenance work and repairs. ProtectLine has a preventative function in protecting physical machining centers from collisions with help from a digital twin. The virtual machining center always runs ahead of the real one and shuts it down in good time if there are any collision risks.

One Stop Solution For All Your
Industrial Automation Product Needs

Motion Technology Products

Screw Jacks



Versions Available
Ball Screw
Trapezoidal Screw

Designs Available
Classic
Cubic
High Performance
Quick Lifting



Mechatronics Products
Lifting Systems

We can Design, Manufacture and Supply Complete Lifting Systems

**Linear Actuation Technology,
Precise Positioning,
Motion Drives and Controls**



ISO : 9001 - 2015

CE Certified Lifting Systems

Member of AGMA

ISO 9001 - 2015
KEMA
NVT - QC
CERTIFICATE NO. 17930224
DUTCH COUNCIL FOR ACCREDITATION

Gears and Gear Drives (India) Pvt Ltd

An ISO 9001-2015 Certified Company **HiTORK**

www.ggdip.com
info@ggdip.com
+91-8088931951 / 58

Company Index

Ace Manufacturing Systems Ltd	34
Arihant Honing & Finishing Technology (I) Pvt Ltd	54
ASENTICS GmbH & Co KG	48
Ashok Leyland	26
Batliboi Ltd	60
Blaser Swisslube	16
Bosch Ltd	64
Chiron Group	69
CNC Software, Inc.	42
Deutsche Messe AG	16
DMG MORI	38
Dutch Tech Tools Pvt Ltd	34
Dynascan Inspection Systems Company	18
Forbes & Company Ltd	34
Forms and Gears	26
Godrej & Boyce Manufacturing	64
Gusti Tool Works LLP	26
Hexagon Manufacturing Intelligence	18
HYDAX Hydraulics Pvt Ltd	18, 60
IMTMA	6, 8, 12, 14, 60, 64
Jyoti CNC Automation Ltd	34
Khutale Engineering	64
Lakshmi Machine Works	16, 60
Mahindra & Mahindra	64
MARPOSS India Pvt Ltd	68
Marshall Machines Ltd	18, 60
METI	20
Micromatic Grinding Technologies Ltd	34
Micromatic Machine Tools Pvt Ltd	24
Minister of Heavy Industry and Public Enterprises	60
Miranda Tools Pvt Ltd	34
PTC	58
Siemens	16
Toyota Kirloskar Motor Pvt Ltd	26
TRUMPF (India) Pvt Ltd	26, 46
UCAM Pvt Ltd	34, 60
VDMA (German Engineering Federation)	48
VDW (German Machine Tool Builders' Association)	32
Yamazaki Mazak India Pvt Ltd	26

Advertiser Index

Accurate Sales & Services Pvt Ltd – www.accurategauging.com	51
Ace Designers Ltd – www.acemicromatic.net	45
ACMEE 2020 – www.acmee.in	67
Andreas Maier Workholding Technology Pvt Ltd – www.amf.de	04
Apex Precision Mechatronix Pvt Ltd – www.apexprecision.co.in	41
Carl Bechem Lubricants (India) Pvt Ltd – www.bechemindia.com	23
Chennai Metco – www.chennaietco.com	10
CGTech India Software Solutions Pvt Ltd – www.cgtech.co.in	53
CHIRON India Machine Tools Pvt Ltd – www.chiron-group.com	19
DC SWISS SA – www.dcswiss.com	05
Diemould India 2020 – www.diemouldindia.org	55
DMG MORI – www.emo.dmgmori.com	11
DYNASCAN Inspection Systems Company – www.dynascan.info	06
EPLAN Software and Services Pvt Ltd – www.eplan.in	08
FIBRO India Precision Products Pvt Ltd – www.fibro.com	25
Gears and Gear Drives (India) Pvt Ltd – www.ggdip.com	70
HYDAX Hydraulics Pvt Ltd – www.hydaxindia.com	24
IMTMA-Chennai Machine Tools Expo 2019 – www.mtx.co.in	61
IMTMA-IMTEX Forming 2020 – www.imtex.in	63
IMTMA-Symposium on Smart Automation – www.imtma.in	57
IMTMA-Technology Centre – www.imtmaelearn.in	65
Jin Shaa Machines – www.jinshaamachines.com	49
Jyoti CNC Automation Ltd – www.jyoti.co.in	03
Khushbu Honing – www.khushbuindia.com	13
Lakshmi Machine Works Ltd – www.lmwnc.com	21
Marposs India Pvt Ltd – www.marposs.com	39
Mitsubishi Electric India Pvt Ltd – www.MitsubishiElectric.in	43
MMC Hardmetal India Pvt Ltd – www.mitsubishicarbide.com	17
MSME Sampark – www.msmetoolroomkolkata.com	07
Okuma India Pvt Ltd – www.okumaindia.com	09
Rajamane Delivering Solutions – www.rajamane.com	15
RV Forms & Gears LLP – www.rvformsandgears.com	71
Taegutec India Pvt Ltd – www.taegutec.com	72
UCAM Pvt Ltd – www.ucamind.com	02
Yamazaki Mazak India Pvt Ltd – www.mazakindia.in	30-31



Asia's Leading Fixture Builder

Presents

IoT enabled Industry 4.0 Fixtures



For over 45 years Forms & Gears has been supplying Precision Machining Centre Fixtures to the world's leading Auto OEMs and Machine Makers in Japan, Germany, UAE, Qatar, Thailand, Turkey, Indonesia and all over India. Forms & Gears now brings you IoT enabled Industry 4.0 fixtures for High Performance Machining.

- ☑ Cloud based application that monitors condition of machines on the floor based on readings collected from sensors on fixtures.
- ☑ Fixture level analytics to help isolate and troubleshoot faster.
- ☑ Graphical data visualisations for more robust analysis.



RV Forms & Gears LLP
MF 11, SIDCO Industrial Estate, Guindy,
Chennai - 600 032, Tamilnadu, India
Call 77570 53326 or email us on
marketing@rvformsandgears.com
www.rvformsandgears.com



6NGU 09

6NKU 04



>>> TOTAL SOLUTION FOR SHOULDER MILLING 90 DEGREE WITH 6 CORNER DOUBLE-SIDED POSITIVE INSERT

- Dovetail mechanism clamping provides increased security and insert clamping
- Helical cutting edge for 90 degree cutting
- Double sided 6 corner insert with helical geometry
- Insert size variants include 6NKU 04, WNGX 05, 6NGU 06, WNGX 08 and 6NGU 09



TaeguTec India Pvt. Ltd.

Plot Nos.119 & 120, Bommasandra Industrial Area, Phase 4, Bengaluru 560 099, India

☎ +91-80-4901 3000 ☎ +91-80-2783-9123 ✉ sales@taegutec-india.com 🌐 www.taegutec-india.com